

**Intergovernmental Science-Policy
Platform on Biodiversity and
Ecosystem Services**

Distr.: General

4 January 2016

English only

**Plenary of the Intergovernmental Science-Policy
Platform on Biodiversity and Ecosystem Services
Fourth session**

Kuala Lumpur, 22–28 February 2016

Item 5 (b) of the provisional agenda*

**Work programme of the Platform: scenarios
and models of biodiversity and ecosystem services****Technical report of the methodological assessment of scenarios
and models of biodiversity and ecosystem services (deliverable
3 (c))****Note by the Secretariat**

At its second session, in section IV of its decision IPBES-2/5, the Plenary of the Intergovernmental Science-Policy Platform on Biodiversity and Ecosystem Services approved the undertaking of a fast-track methodological assessment of scenarios and modelling of biodiversity and ecosystem services for consideration by the Plenary at its fourth session, as outlined in the scoping report set out in annex VI to that decision. In accordance with the decision an assessment report and a summary for policymakers for the assessment were produced by an expert group in accordance with the procedures for the preparation of the Platform's deliverables.¹ The summary for policymakers is before the Plenary for its approval in document IPBES/4/4. The full technical report on the methodological assessment of scenarios and models of biodiversity and ecosystem services is before the Plenary for its acceptance in the annex to the present note. It has not been formally edited.

* IPBES/4/1.

¹ IPBES/2/17, annex, decision IPBES-2/3, annex.

Annex

Table of contents

Chapter 1	Overview and vision.....	3
Chapter 2	Using scenarios and models to inform decision making in policy design and implementation.....	34
Chapter 3	Building scenarios and models of drivers of biodiversity and ecosystem change	82
Chapter 4	Modelling impacts of drivers on biodiversity and ecosystems.....	116
Chapter 5	Modelling consequences of change in biodiversity and ecosystems for nature’s benefits to people.....	155
Chapter 6	Linking and harmonizing scenarios and models across scales and domains.....	190
Chapter 7	Building capacity for developing, interpreting and using scenarios and models	218
Chapter 8	Improving the rigour and usefulness of scenarios and models through ongoing evaluation and refinement	249

Chapter 1 Overview and vision

Coordinating Lead Authors:

Simon Ferrier (Australia), Karachepone N. Ninan (India)

Lead Authors:

Paul Leadley (France), Rob Alkemade (the Netherlands), Grygoriy Kolomytsev (Ukraine), Monica Moraes (Bolivia), Yongyut Trisurat (Thailand), Essam Yassin Mohammed (Eritrea)

Review Editors:

Beth Fulton (Australia), Carlos Joly (Brazil)

Purpose of this chapter: Introduces the background, purpose and scope of the Methodological Assessment of Scenarios and Models of Biodiversity and Ecosystem Services; provides a general introduction to the role of scenarios and models in policy and decision making; and outlines the structure of the remaining chapters of the report.

Target audience: A broader, less technical audience than for the other chapters of the report, each of which examines in greater depth a subset of issues and challenges associated with scenario analysis and modelling. Readers interested in obtaining only a general overview of the topic of scenarios and models may wish to read no more than this chapter.

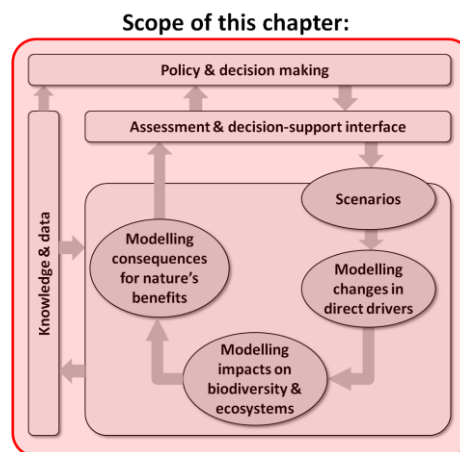

1.1 Introduction

For the purposes of this assessment, ‘models’ are defined as qualitative or quantitative representations of key components of a system and of relationships between these components.

Throughout this assessment, and in most Intergovernmental Platform on Biodiversity and Ecosystem Services (IPBES) activities, the term ‘models’ usually, but not exclusively, refers to quantitative descriptions of relationships: i) between indirect drivers and direct drivers; ii) between direct drivers and nature (including biodiversity and ecosystems); and iii) between nature and nature’s benefits to people (including ecosystem services). Each of these relationships is discussed in more detail later in this chapter.

In this assessment ‘scenarios’ are defined as plausible representations of possible futures for one or more components of a system, or as alternative policy or management options intended to alter the future state of these components.

Throughout this assessment the term ‘scenarios’ usually refers to plausible futures for indirect or direct drivers, or to policy interventions targeting these drivers. The consequences of these scenarios for nature and nature’s benefits to people are then typically evaluated using models as defined above.

Scenarios and models have potential to contribute significantly to achieving the overarching goal of IPBES ‘to strengthen the science-policy interface for biodiversity and ecosystem services for the conservation and sustainable use of biodiversity, long-term human well-being and sustainable development’. Their use in assessments, policy support and decision making offers many benefits, including to ‘better understand and synthesize a broad range of observations; alert decision makers to undesirable future impacts of global changes such as land use change, invasive alien species, overexploitation, climate change and pollution; provide decision support for developing adaptive management strategies; and explore the implications of alternative social-ecological development pathways and policy options. One of the key objectives in using scenarios and models is to move away from the current reactive mode of decision-making in which society responds to the degradation of biodiversity and ecosystem services in an uncoordinated, piecemeal fashion to a proactive mode in which society anticipates change and thereby minimizes adverse impacts and capitalizes on important opportunities through thoughtful adaptation and mitigation strategies’ (IPBES/2/17, annex VI²)

1.1.1 Purpose and scope of this assessment

The Methodological Assessment of Scenarios and Models was initiated in order to ‘to establish the foundations for the use of scenarios and models in activities under the Intergovernmental Science-Policy Platform on Biodiversity and Ecosystem Services’ (IPBES/2/17, annex VI, www.ibpes.net).

It is one of the first assessment activities of IPBES because it provides guidance on the use of scenarios and models in the regional, global and thematic assessments, provides IPBES task forces and expert groups with recommendations in terms of supporting and mobilizing scenarios and modelling expertise and identifies key gaps that need to be addressed in collaboration with the scientific community, policy makers and others. There are a large number of reviews providing typologies of scenarios and models and summarizing their strengths and weaknesses (Coreau et al., 2009; IEEP et al., 2009; Bellard et al., 2012; Kelly et al., 2013; Harfoot et al., 2014a; Rounsevell et al., 2014), but all of these have a much narrower scope than this assessment and do not provide recommendations that are specifically adapted to the IPBES mandate. Overall, this assessment provides an overview of scenarios and models, a critical analysis of the types and uses of scenarios and models currently available and perspectives on the development of new methods in the near future.

² For official IPBES documents cited in this assessment, see the IPBES web site at www.ibpes.net under the tab “Plenary Sessions”. The first number in the IPBES document reference indicates the number of the plenary session.

There are several audiences for this methodological assessment, with the primary audiences differing substantially between the Summary for Policy Makers (SPM), Chapter 1 and the following chapters.

The SPM and Chapter 1 have been written with non-experts in mind so that they are accessible for a broad audience including members of the IPBES plenary, policy makers and other stakeholders. The critical analysis and perspectives in Chapters 2-8 of this assessment are more technical in nature and address the broader scientific community in addition to the expert groups and task forces of IPBES. In all of the chapters, highly technical descriptions and jargon have been kept to a minimum as much as possible.

The intended target audiences within IPBES include:

- Plenary, Bureau and Multidisciplinary Expert Panel (MEP): the SPM and Chapter 1 provide a broad overview of the potential benefits and caveats in making use of scenarios and models, better integration across existing IPBES activities and priorities for future activities of IPBES.
- Task forces and expert groups involved in catalysing, facilitating and supporting use of scenarios and models within IPBES and beyond: the full assessment provides guidance on priorities and proposed solutions for linking work on scenarios and models across IPBES deliverables, and for mobilizing the broader scientific community.
- Regional, global and thematic assessments: the SPM and Chapter 1 give all involved experts an overview of the benefits and caveats in making use of scenarios and models, and provides experts working specifically on scenarios and models with guidance on more technical issues related to the application of scenarios and models in assessments.

Target audiences outside of IPBES include:

- This document provides guidance to policy makers and implementers at local to global scales, as well as assessment and decision-support practitioners employing scenarios and models. Guidance to these audiences focuses on appropriate and effective use of scenarios and models across a broad range of decision contexts and scales.
- For the scientific community and science funding agencies this assessment provides analyses of key knowledge gaps that if filled would greatly increase the utility of scenarios and models for IPBES, as well as other science-policy interfaces. Summaries of these knowledge gaps can be found in the SPM and Chapter 1, with more detailed analyses in subsequent chapters, especially Chapter 8.

The scope of the assessment covers a broad range of scenarios and models. The objective is to provide guidance for ‘evaluating alternative policy options using scenarios and models; including multiple drivers in assessments of future impacts; ... including input from stakeholders at various levels; implementing capacity-building mechanisms to promote the development, use and interpretation of scenarios and models by a wide range of policymakers and stakeholders; and communicating outcomes of scenario and model analyses to policymakers and other stakeholders’ (IPBES/2/16/Add.4, www.ibpes.net).

Follow-up work by an expert group is envisaged to start following the completion of this assessment in 2015 and will continue through 2017 and possibly beyond. One of the tasks of this expert group will be to establish an ‘evolving guide’ on scenarios and models.

The exact nature of this evolving guide remains to be defined, but since methods are changing very rapidly, it is important that the guidance provided in this assessment is updated on a regular basis. The expert group will also interact with other IPBES deliverables and the broader scientific community to stimulate work on scenarios and models that support IPBES objectives. It is envisaged that this will be similar to the interactions between the Intergovernmental Panel on Climate Change (IPCC) and the scientific community that have been created in order to develop scenarios and models for climate change assessment.

1.1.2 Background and context

Scenarios and models of biodiversity and ecosystems have been a key component of most global, regional and national environmental assessments carried out over the last decade.

The IPCC, which is the institutional equivalent of IPBES for climate change issues, has amply demonstrated the power of scenarios and models as a cornerstone of the science-policy dialog surrounding climate change and in popularizing climate change issues. The use of scenarios and models of biodiversity and ecosystem services in global and sub-global assessments is more recent. The first global assessment with a substantial component of scenarios coupled with models of biodiversity impacts was the Millennium Ecosystem Assessment (MA) released in 2005 (MA 2005). Assessments with significant use of scenarios and models to evaluate ecosystem services are even more recent (e.g., UK NEA, 2011).

Scenarios and models in assessments of biodiversity and ecosystem services have played an important role in agenda setting by alerting the scientific community, natural resource managers and politicians to the possible future risks for

biodiversity and ecosystem services, and to some extent in policy formulation by illustrating possible solutions for reducing these risks (Wilson et al., 2014). Examples include the most recent IPCC assessment and the MA which have called attention to the possibility of greatly increased species extinction risk by 2050 driven by future land use and climate change (MA, 2005, IPCC, 2014a). The most recent Global Biodiversity Outlook (GBO) used scenarios and models called attention to the transformations of socio-economic development paths that are needed to achieve internationally agreed upon goals for climate, biodiversity and human development by 2050 (SCBD GBO4 2014, Leadley et al., 2014; see also Table 1.1 in Section 1.5.2).

Scenarios and models of biodiversity and ecosystems are used in many contexts outside of global, regional and national environmental assessments. In particular, a wide range of policy support methodologies have been developed to allow more direct use of scenarios and models in policy design, implementation and evaluation (see Chapter 2). The bulk of this work has been done at local scales (see two examples in Table 1.1), but some methodologies are also pertinent at national to global scales. Experience shows that successful application of models and scenarios to policy design, implementation and evaluation requires sustained interactions between stakeholders, managers, policy makers and modellers. Numerous examples illustrating these applications are provided in this and subsequent chapters, particularly in boxes describing case studies.

A variety of approaches have been used for developing and presenting scenarios and models in environmental assessments, and very rapid progress in the development and use of scenarios and models of biodiversity and ecosystem services over the last decade (Figure 1.1) means that IPBES is now well positioned to make substantial use of these methodologies in all of its activities.

In some cases, assessment bodies have opted to support the development of a common set of scenarios of direct and indirect drivers, as well as accompanying models of impacts on biodiversity and ecosystems. Examples include the global assessments such as the Millennium Ecosystem Assessment (MA, 2005), early Global Biodiversity Outlooks (sCBD, 2006), and Global Environment Outlooks (GEO) (e.g., UNEP, 2007), as well as some national and regional assessments (Southern Africa, van Jaarsveld et al. (2005); Japan, SSA (2010); UK, UK NEA, 2011; Wilson et al., 2014). At the opposite end of the spectrum some assessments have focused on synthesizing a broad range of published analyses of scenarios and modelling studies available in the literature (e.g., sCBD, 2010, Leadley et al., 2010, UNEP, 2012). Still others fall in between these extremes, for example the IPCC climate modelling has traditionally relied on a common set of scenarios of direct and indirect drivers developed specifically for the assessment, while assessment of projected impacts on biodiversity and ecosystems is primarily based on analyses of peer-reviewed literature (e.g., sCBD, 2014, IPCC, 2014a, IPCC, 2014b). The advantage of using a common set of scenarios and models is that they provide a clear and homogenous analysis that may be easier for non-specialists to understand: the disadvantages are that these typically are useful for a very limited range of spatial and temporal scales and decision contexts. The advantages of analyses based on a broad spectrum of published work is that they provide much greater insight into assumptions underlying scenarios and models and their associated uncertainties, and address a wide variety of scales and decision contexts because they cover a much larger evidence base. However, very diverse assumptions and indicators used in published work make synthesis difficult (Pereira et al., 2010).

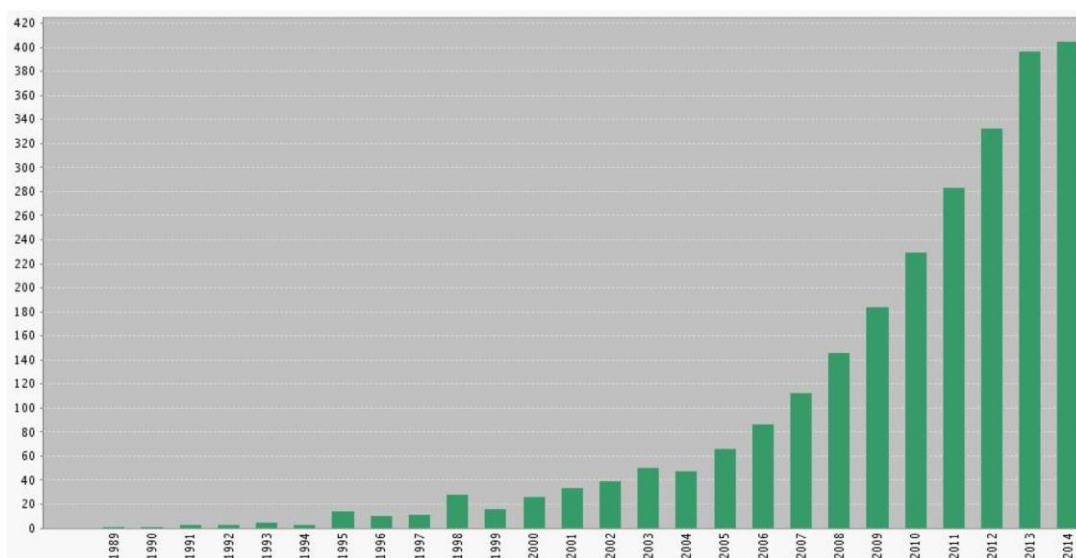

Figure 1.1: Change over time in the number of articles published in scientific journals related to future projections of biodiversity and ecosystem services based on scenarios and models. The search pattern used for this analysis has high specificity (a correction for errors of commission has been applied), but is also subject to errors of omission (which are much more difficult to estimate and have not been corrected for). As such, the true number of articles is likely to be substantially higher than indicated here. (Search pattern used 1 Nov 2015 in Web of Science: TS = (Future AND (projection* OR prediction* OR forecast* OR scenario*) AND ('ecosystem service' OR 'ecological service' OR

biodiversity OR ‘biological diversity’ OR ‘species richness’ OR ‘species diversity’ OR ‘species distribution’ OR ‘species conservation’ OR ‘species range’ OR ‘biological conservation’ OR ‘nature conservation’). Errors of commission were estimated to be ca. 14% based on a subsample of abstracts, and were substantially higher with older publications. Results were relatively insensitive to removal of individual search terms with the exception of ‘future’: removal of this search term lead to very high errors of commission).

Despite the use of scenarios and models of biodiversity and ecosystem services in several major global and sub-global assessments it is difficult to evaluate their role in influencing decision making and popularizing biodiversity and ecosystem services, although there is evidence of uptake in national and international policy (Wilson et al., 2014).

More broadly, a variety of factors hamper more widespread use of scenarios and models in policy making and management.

These factors include the relatively recent development of scenarios and models for biodiversity and ecosystem services (Figure 1.1), generally insufficient validation of models, insufficient dialog between scientists and decision makers and biases in the types of drivers, types of ecosystems, taxonomic coverage of biodiversity, spatial scales and temporal scales (see Section 1.6 and Chapters 2 and 8 for details).

1.1.3 Structure of remainder of this chapter

Section 1.2 introduces the fundamental role that models can play in describing relationships between elements of the IPBES Conceptual Framework (1.2.1). It then outlines major types of models of relevance to IPBES activities (1.2.2), and acknowledges the dual contribution that many of the models considered in this assessment (focusing on future change) can also make to assessing past-to-present status and trends in biodiversity and ecosystem services (1.2.3).

Section 1.3 explains how coupling models with scenarios enables the translation of plausible futures for drivers of change, and/or alternative policy interventions, into expected consequences for biodiversity and ecosystem services (1.3.1). It then outlines major types of scenarios and their relationship with different phases of the policy cycle (1.3.2).

Section 1.4 describes how scenarios and models can inform policy and decision making through a variety of assessment or decision-support interfaces.

Section 1.5 explains the importance of matching employed scenarios, models and interfaces to the needs of different policy or decision-making contexts (1.5.1). It then presents examples of the effective use of scenarios and models of biodiversity and ecosystems services in previous assessment and decision-support activities (1.5.2).

Section 1.6 highlights the need to better recognise, understand and address current limitations of scenarios and models of biodiversity and ecosystem services, including deficiencies in the spatial, environmental, and thematic coverage of existing scenarios and models (1.6.1), gaps in the availability of underpinning knowledge and data (1.6.2), and challenges in dealing with uncertainty (1.6.3).

Section 1.7 outlines the chapter structure of the remainder of the report.

1.2 Describing relationships between elements of the IPBES Conceptual Framework with models

1.2.1 Overview

The IPBES Conceptual Framework (Figure 1.2, Diaz et al. (2015) provides a logical starting point for introducing, and explaining, the respective roles of scenarios and models within the context of IPBES.

This framework emerged from an extensive process of consultation and negotiation, leading to formal adoption by the second IPBES Plenary (IPBES/2/4), and therefore represents a key foundation for all IPBES activities. It is a simplified representation of the complex interactions between the natural world and human societies. IPBES recognizes and considers different knowledge systems, including indigenous and local knowledge (ILK) systems, which can be complementary to those based on science. The Conceptual Framework is therefore intended to serve as a tool for achieving a shared working understanding across the different disciplines, knowledge systems and stakeholders that are expected to be active participants in IPBES.

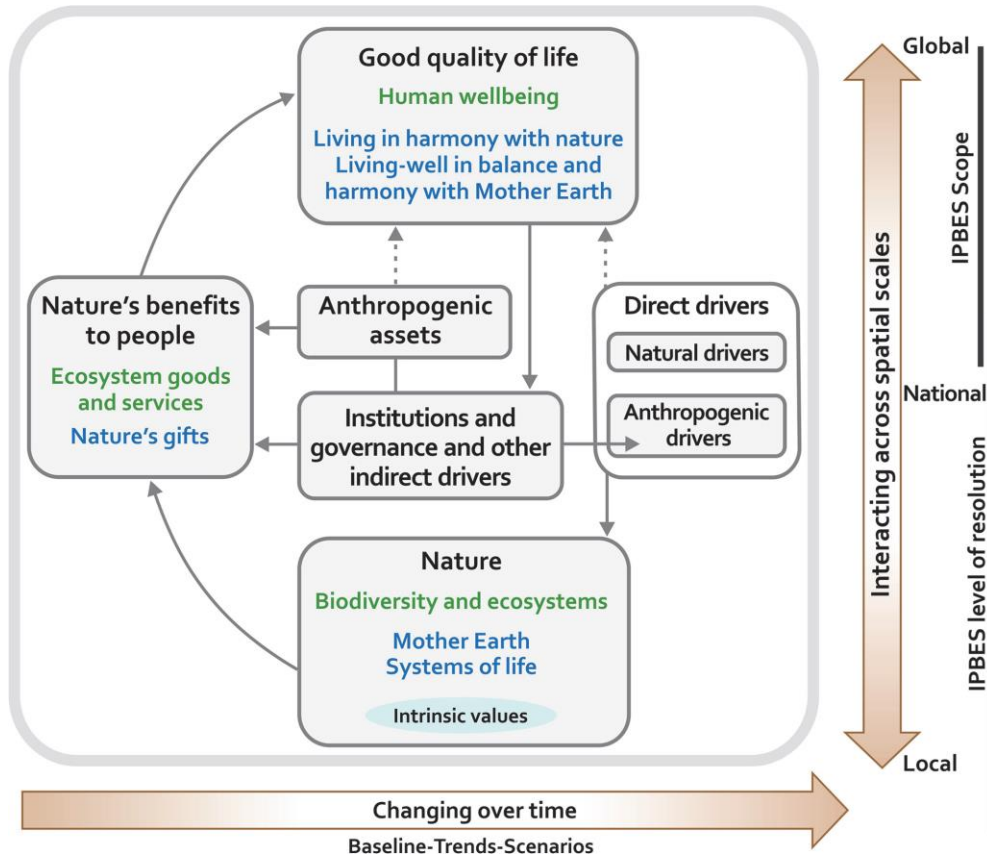

Figure 1.2: The IPBES conceptual framework, from Diaz et al. (2015). This depicts the main elements and relationships for the conservation and sustainable use of biodiversity and ecosystem services, human well-being and sustainable development. Similar conceptualizations in other knowledge systems include ‘living in harmony with nature’ and ‘Mother Earth’, among others. In the main panel, delimited in grey, ‘nature’, ‘nature’s benefits to people’ and ‘good quality of life’ (indicated as black headlines) are inclusive of all these world views; text in green denotes the concepts of science; and text in blue denotes those of other knowledge systems. Solid arrows in the main panel denote influence between elements; the dotted arrows denote links that are acknowledged as important, but are not the main focus of the Platform. The thick coloured arrows below and to the right of the central panel indicate different scales of time and space, respectively.

As explained by Diaz et al. (2015), this framework provides a conceptual foundation for the science-policy interface through which knowledge from science, and other knowledge systems, flows through to policy and decision-making via the four main functions of IPBES – i.e., knowledge-generation, assessment, policy-support, and capacity-building.

Models can make a significant contribution to enabling the flow of data and knowledge to policy and decision-making by explicitly describing interactions between major elements of the IPBES Conceptual Framework (Figure 1.3).

In the original framework (Figure 1.2) arrows are used simply to indicate the existence of relationships between elements but convey very little about the precise nature of these relationships. The arrows linking elements in this framework therefore collectively constitute a conceptual model. Replacing these conceptual links with more quantitative descriptions of each of these relationships allows observed, or projected, changes in the state of one element to be used to estimate, or project, resulting changes in other elements.

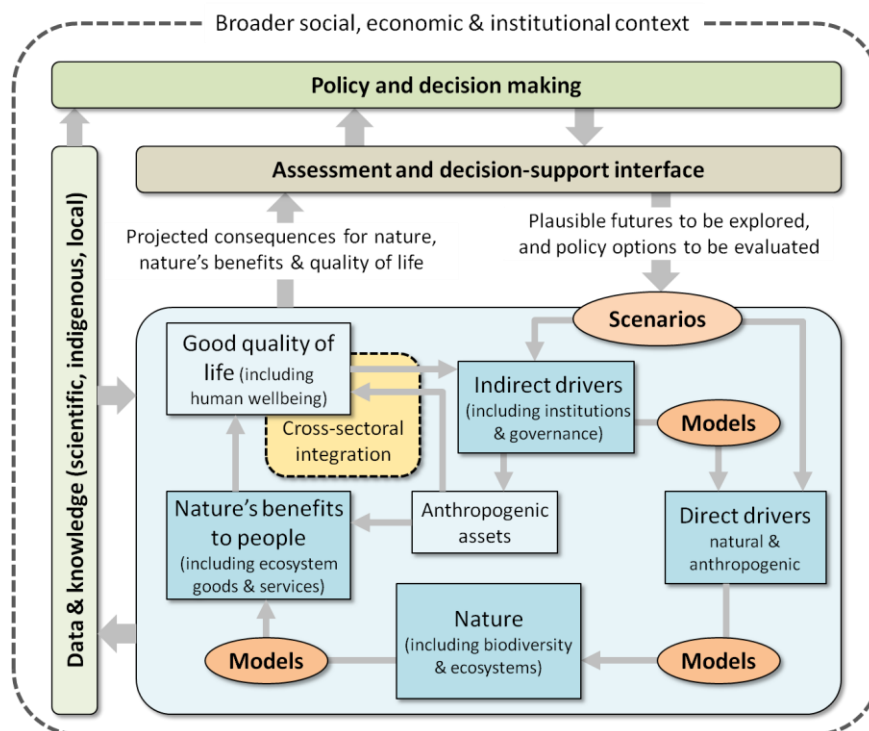

Figure 1.3: High-level roles of scenarios and models in assessment and decision support. The rectangular boxes in the lower blue-shaded portion of the diagram represent key elements from the IPBES Conceptual Framework (see Figure 1.2; but note that in the current figure, due to space constraints, elements are translated only into terms commonly used in the scientific literature, e.g., ‘Nature’ into ‘biodiversity & ecosystems’, and terms used in other knowledge systems are not depicted). Scenarios and models are directly dependent on data and knowledge for their construction and testing, and add value by synthesizing and organizing this knowledge (box and arrows on left). They usually contribute to policy and decision making through some form of ‘interface’ – i.e., assessments, formal decision-support tools, or informal interactions (boxes and arrows at top). This interface manages the translation of high-level policy and decision-making needs into explicit scenarios describing plausible futures for drivers of change and/or alternative policy interventions. Models are then used to evaluate these scenarios in terms of expected consequences for nature and nature’s benefits to people. The ‘cross-sectoral integration’ element added to this framework signifies that any comprehensive assessment of human well-being and good quality of life is likely to require integration of modelling across multiple sectors (e.g., energy, health), thereby dealing with a broader set of relevant goals and values than those mediated directly by biodiversity or ecosystems.

1.2.2 Types of models of relevance to IPBES activities

A diverse range of models are of potential relevance within the context of IPBES. These models vary in two main ways:

- *What relationships are modelled* – i.e., the outputs or ‘response variables’ of interest, and the inputs used to predict or project these outputs.
- *How these relationships are modelled* – i.e., the way in which the link between input and output variables is represented.

1.2.2.1 What relationships are modelled

The models considered in this methodological assessment address three main types of relationship within the IPBES Conceptual Framework (Figures 1.3 and 1.4):

- **Models addressing the effects of changes in indirect drivers** (e.g., socio-political, economic, technological and cultural factors) **on direct drivers** of change in nature (e.g., land-use change, fishing pressure, climate change, invasive alien species, nitrogen deposition);
- **Models addressing the impacts of changes in direct drivers on nature**, including biodiversity and ecosystem functioning; and
- **Models addressing the consequences of changes in nature for the benefits that people derive from nature**, and that therefore contribute to good quality of life (human well-being) – including, but not limited to, ecosystem goods and services.

Models addressing the effects of changes in indirect drivers on direct drivers are often developed for a wide range of purposes that are not expressly intended for use in modelling impacts on nature or nature's benefits to people. Where modelling of direct drivers has already been undertaken by communities of practice within other domains – e.g., climate modelling, land-use modelling – then resulting projections of these drivers can serve directly as inputs to biodiversity and ecosystem models. In this situation existing projections of direct drivers function effectively as scenarios of possible futures for the purposes of modelling consequences for nature and nature's benefits (Figure 1.3). In other situations interest may be focused on modelling consequences of scenarios of indirect drivers, rather than direct drivers. In this case modelling of the effects of indirect-driver scenarios on direct drivers will need to be undertaken as a first step in modelling consequences for nature or nature's benefits. Such models are therefore covered in Chapter 3 of this assessment. It should be noted that the development of scenarios of indirect drivers also often involves models of various types, including human demographic models, governance models, economic models and agent-based models describing behaviour of social systems (Figure 1.4). However, for the purpose of this assessment, it is assumed that such modelling will typically be undertaken outside the core domain of IPBES (see Chapter 3 for further explanation).

A tremendous variety of variables are simulated, and thereby predicted or projected, by models of nature (biodiversity and ecosystem functioning) and nature's benefits (Figure 1.4).

In some cases only a single variable is simulated. For example, species distribution models are often used to predict the spatially-explicit response of just one variable, i.e., species presence or absence, to environmental change. In other cases, models predict multiple variables, but typically only a small subset of the variables listed in Figure 1.4. For example, biodiversity models simulate dynamics of genes, or species, or functional groups, or communities; but most focus on only one of these levels and none simulate biodiversity dynamics at and between all these levels.

In practice, relationships between variables linking the three main components of nature and nature's benefits differ greatly in the frequency and detail with which they are treated in the scientific literature and assessments (Figure 1.4). For example, models of ecosystem function, especially at large spatial scales, typically represent biodiversity using a small number of groups of species that have similar characteristics (i.e., functional groups). A few models of ecosystem function use species level variables, but very few incorporate variables related to genetic adaptation (but see Kramer et al. 2010). Models of nature's benefits typically rely on empirical relationships between habitat type and ecosystem services (arrow directly from habitat), or use inputs from variables simulated by models of ecosystem function, but few account for the contribution of species diversity to ecosystem function (Cardinale et al., 2012), but note that some models do account for a small set of key species interactions).

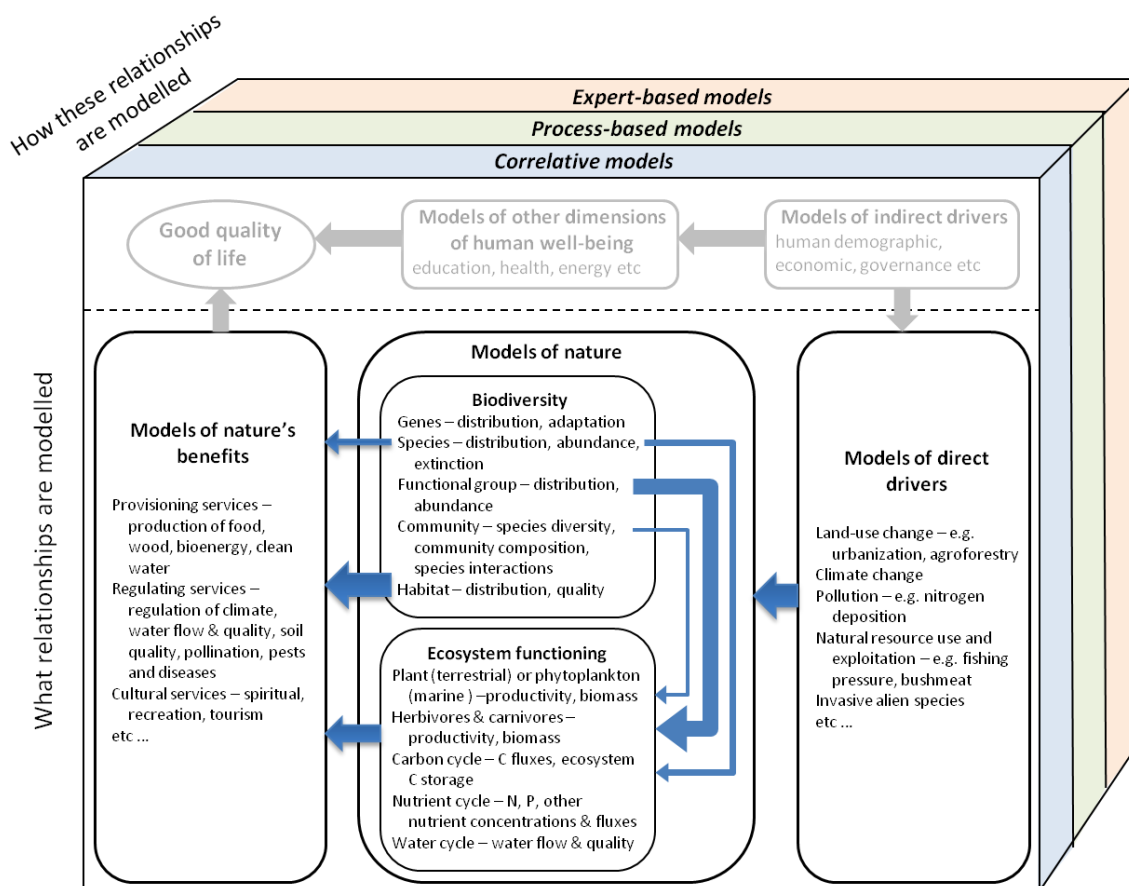

Figure 1.4: Major types of models of relevance to IPBES activities, classified according to ‘what relationships are modelled’ and ‘how these relationships are modelled’. The thickness of the blue arrows indicates the frequency with which model components, or specific variables within these components, are connected by modelling approaches most commonly used at present. The two greyed model types at the top of the diagram – ‘models of indirect drivers’ and ‘models of other dimensions of human well-being’ are of less direct relevance, and are typically dealt with by communities of practice external to that of IPBES.

Modelling of nature’s benefits to people can serve as a key input to assessing human well-being, and therefore good quality of life (Figures 1.3 and 1.4). Such assessments will, however, typically require broader consideration, and therefore modelling, of dimensions of human well-being beyond those mediated primarily by biodiversity or ecosystems – e.g., education, health, energy.

Modelling of these other dimensions is most often undertaken within domains or sectors largely external to that of IPBES, and these models are therefore not covered in any detail by this report. However the report does recognise the growing need for cross-sectoral integration of models trade-offs and synergies between these dimensions (e.g., {Hilderink, 2008 #3}, particularly within the context of the UN’s recently ratified Sustainable Development Goals (SDGs)

(<https://sustainabledevelopment.un.org/>; see also Section 1.4, Chapters 2, 5 and 6).

As depicted in Figures 1.3 and 1.4, models of drivers, nature and nature’s benefits can be implemented as a linked chain, where the input for one model is derived from the output of the previous model in the chain (e.g., {Bateman, 2013 #5}, Nelson et al., 2009). Increasingly, however, models such as these are being integrated even more strongly by treating them as components of a single modelling framework, thereby enabling more effective consideration of interactions and feedbacks between these components. Examples of this level of integration include end-to-end ecosystem models (e.g., Fulton, 2010) and integrated assessment models (e.g., Stehfest et al., 2014).

Integrated assessment models (IAMs) combining modelling of multiple environmental, social and economic system components are being used increasingly in global and regional assessment activities.

Integrating very different types of knowledge within IAMs is particularly challenging (e.g., De Vos et al., 2013), but necessary if these approaches are to provide an effective foundation for assessing human well-being, and quality of life. While IAMs usually account for at least some ecosystem functions and services, they often exclude key ecosystem functions and omit cultural services, and generally lack representation of biodiversity below the functional group or habitat type level (Harfoot et al., 2014a), but see Alkemade et al. (2009) for examples of including species diversity in global integrated models). Regardless of the precise approach used to link or integrate models, great care needs to be taken to account for propagation of error, consistency of variables, differences in spatial and temporal resolution, and costs and benefits of increasing complexity (see Chapter 6).

1.2.2.2 How relationships are modelled

The relationship between input and output variables can be represented or described by a model in many different ways, both quantitative and qualitative (Börner et al., 2012; Ritchey, 2012).

Three broad approaches to modelling relationships between input and output variables are recognised throughout this assessment (Figure 1.4, and see Chapter 4 for further explanation):

- **Correlative models**, in which available empirical data are used to estimate values for parameters that do not have predefined ecological meaning, and for which processes are implicit rather than explicit.
- **Process-based models**, in which relationships are described in terms of explicitly stated processes or mechanisms based on established scientific understanding, and model parameters therefore have clear ecological interpretation, defined beforehand.
- **Expert-based models**, in which experience of experts and stakeholders, including local and indigenous knowledge holders, is used to describe relationships.

Correlative modelling is probably the best known, and most widely applied, of these three approaches, due largely to the popularity of correlative species distribution modelling in recent years (Elith and Leathwick, 2009).

Process-based modelling encompasses a wide range of techniques, many of which represent underlying processes using mathematical equations – e.g., modelling of population and meta-population dynamics (e.g., Brook et al., 2000; Gordon et al., 2012), and of ecosystem function (e.g., Harfoot et al., 2014b). Other techniques in this class represent underlying processes as quantitative rules rather than as equations – e.g., rule-based modelling to inform extinction risk assessment (e.g., Mace et al., 2008).

Expert-based modelling also encompasses a wide variety of techniques, in this case for capturing and representing expert knowledge of relationships between variables of interest (e.g., Priess and Hauck, 2014; Walz et al., 2007). In this context an ‘expert’ is considered to be anyone who has acquired good knowledge of a subject through her/his life

experience (Kuhnert et al., 2010), including local or indigenous knowledge holders in addition to scientists. It is assumed, however, that the expert is a reliable source of information within a specific domain (Burgman, 2005).

Some modelling techniques allow these different approaches to be combined within a single model – e.g., in Bayesian Belief Networks expert-based knowledge can be combined with information derived through correlative or process-based approaches (Haines-Young, 2011).

A variety of modelling approaches may often be available for addressing a particular question. The position taken throughout this methodological assessment is that there is usually no single best modelling approach for any given application. In particular, debates about the use of models working with correlative vs. process-based vs. expert-based models are frequently polluted by misconceptions about the usefulness of these various types of models. Many modelling exercises have clearly illustrated the benefits of examining multiple model types in terms of understanding of underlying processes, improving the ability to simulate biodiversity and ecosystem functions, providing complementary sets of variables and estimating uncertainty (Cheaib et al., 2012; Gritti et al., 2013; van Oijen et al., 2013). The use of multiple models does not necessarily require quantitative comparisons among models. However, in some cases IPBES may want to stimulate work on quantitative multi-model comparisons since, as the IPCC has amply demonstrated for climate models and some models of impacts on ecosystems (IPCC, 2014a), these can often carry more weight in decision making than individual models. This does not mean that all models are equally good. As such, models need to be thoroughly tested with independent data and an evaluation of the strengths and weaknesses of models should ideally be included when presenting model outcomes. The following chapters provide more specific guidelines for selecting models, and for evaluating their strengths and weaknesses.

1.2.3 Using models to assess past-to-present status and trends

This assessment is focused primarily on the use of models, in conjunction with scenarios, to explore potential changes in nature and nature's benefits into the future. However, before adopting this particular focus throughout the remainder of this report, it is worth noting that modelling can, and does, also play an important role in assessing status and trends even in the absence of scenarios.

All of the approaches outlined above require, as input, information on the state of one element of the IPBES conceptual framework, which a model then uses to predict, or project, the state of another element. These models can therefore be applied either to future projections of input variables (based on scenarios; see Section 1.3) or to actual observations (data) for these same input variables (Figure 1.5). The latter option can help to shed valuable light on the present status of nature and its benefits, and on changes or trends in this status past-to-present (Leadley et al., 2014). Several elements of the IPBES conceptual framework align well with major categories of indicators within the widely adopted 'drivers-pressures-states-impacts/benefits-responses' (DPSIR) approach to status-and-trend assessment (Feld et al., 2010; Sparks et al., 2011). Modelling can add considerable value to such assessments in two important ways:

- Modelling can help to fill gaps in the data needed to underpin key indicators. While ongoing data acquisition is clearly of vital importance (see Section 1.6 and Chapter 8) data are much easier and/or less costly to obtain for some elements of the IPBES conceptual framework than for others. For example, advances in remote sensing have now made it possible to track temporal changes in a number of direct drivers (pressures), including habitat conversion and climate change, at relatively fine spatial resolutions across extensive regions (Hansen et al. 2013). On the other hand, most components of biodiversity, particularly at the species and genetic levels, are not detectable through remote sensing, and changes in their state can be observed only through direct field survey. Such data therefore tend to be sparsely and unevenly distributed across both space and time. Modelling offers a cost-effective means of filling gaps in this coverage by using remotely derived, and therefore geographically complete, information on drivers to estimate changes in the state of biodiversity (past to present) expected across unsurveyed areas (Ferrier, 2011; Leutner et al., 2012; Turner, 2014). Using modelling to fill gaps in information can play an equally valuable role in assessing status and trends in nature's benefits to people – e.g., by estimating changes in the supply of ecosystem services, relative to the distribution of people receiving these benefits, from remotely-sensed land cover classes and structural or functional ecosystem attributes (biomass, net primary production, etc.) (Tallis et al., 2012; Andrew et al., 2014).
- Modelling can provide a process-based alternative to the use of composite indicators in integrating multiple pressure-state-response indicators. Applications of the DPSIR framework typically generate large numbers of indicators (Butchart et al., 2010; Sparks et al., 2011), distinguished not only by their focus on different high-level components of this framework (e.g., pressure indicators versus state indicators versus response indicators) but also by differences in the focus of indicators within each component – e.g., indicators of habitat-conversion pressures versus invasive-species-alien-species pressures; or indicators of habitat-protection (reservation) responses versus invasive-species-control responses. To provide a better sense of the overall status of, and trends in, the condition or 'health' of the system as a whole these individual indicators are sometimes aggregated to produce one, or a small number of, composite indicators or indices (e.g., Halpern et al., 2012). While aggregation will often be most readily achieved through simple summation or multiplication (Butchart et al., 2010), this may fail to adequately address the often complex, non-linear nature of interactions between multiple pressure, state and response elements in real-world systems. Modelling offers an alternative means of integrating data, and

indicators, describing past-to-present changes across multiple system elements, and thereby better accounting for complexities and dynamics in these interactions (Vackar et al., 2012; Pereira et al., 2013; Tett et al., 2013).

1.3.1 Overview

Policy and decision-making processes often require looking beyond the present to the future. Questions raised in these processes might include: What is the risk of future loss of nature, or nature's benefits to people? How would alternative policy or management interventions alter this outcome? Using models to address questions relating to possible changes in the future, rather than to actual changes in the present or recent past, poses special challenges. In this situation observations of change (e.g., in drivers) are not available to use as inputs to models, because these changes are yet to occur. Furthermore there is often considerable uncertainty associated with the future trajectory of any given input variable, because this trajectory will be affected by events and decisions that have also not yet occurred, and are often highly unpredictable. Scenarios provide a useful means of dealing with the reality that not just one, but many, futures are possible (Pereira et al., 2010; Cook et al., 2014).

Scenarios and models play different, but highly complementary, roles in informing and supporting policy and decision-making (Figures 1.3 and 1.5). Scenarios are used to describe plausible futures for drivers of change, and options for altering the course of these drivers through policy and management interventions. Models then enable scenarios of change in drivers to be translated into expected consequences for nature and nature's benefits to people.

1.3.2 Types of scenarios relating to different phases of the policy cycle

What exactly is meant by 'policy and decision-making'? The adoption of this term in Figure 1.3 follows its use in various other IPBES documents including, for example, documentation of the Conceptual Framework (Decision IPBES-2/4, <http://www.ipbes.net/>). However, policy and decision-making can encompass a very broad range of processes and activities conducted in a wide variety of contexts across multiple scales.

Numerous frameworks have been proposed over recent decades for conceptualising phases or elements of the policy cycle, and similar frameworks have also been developed for describing adaptive planning or management cycles. There is considerable commonality between most of these frameworks. For the purposes of this assessment, four broad phases of the policy cycle are recognised (see Chapters 2 and 3 for further detail): 1) agenda setting; 2) policy design; 3) policy implementation (also referred to as 'planning and management' in parts of the report); and 4) policy review.

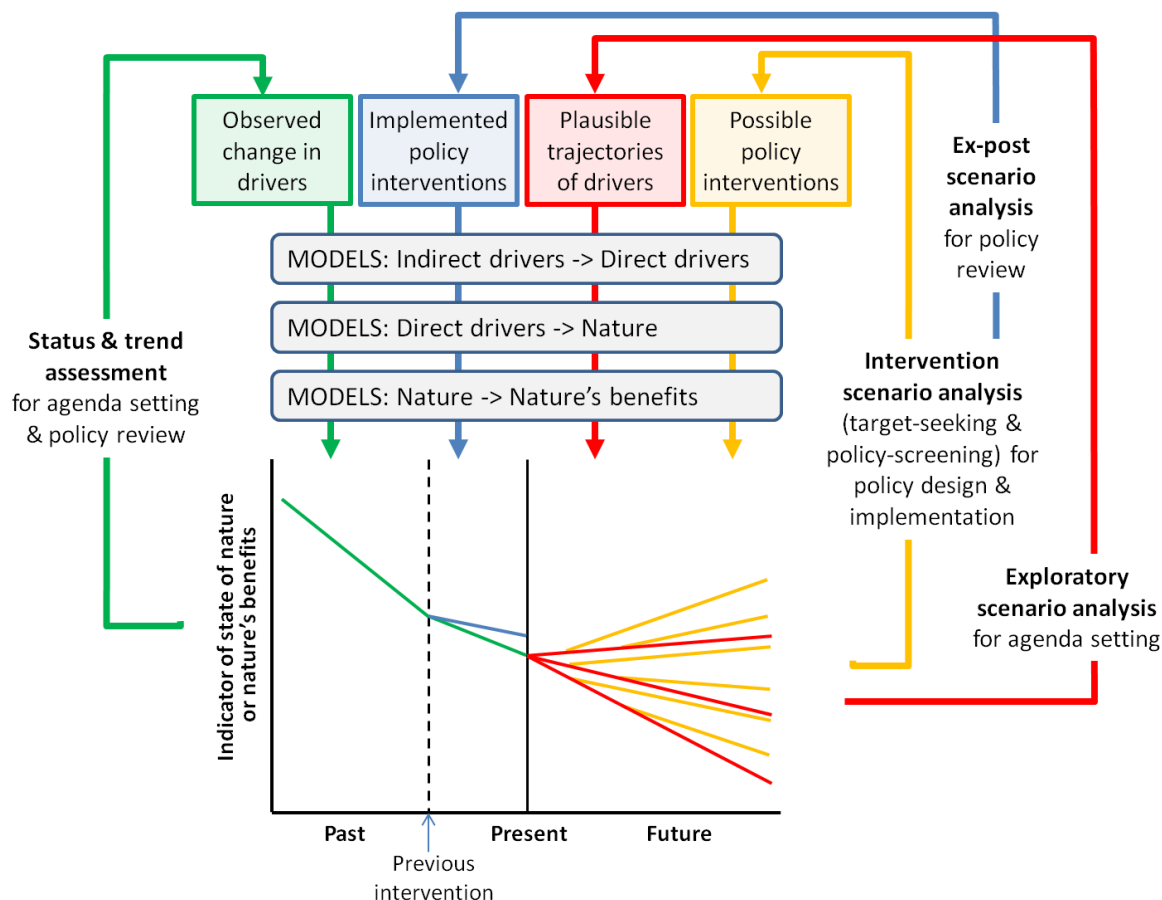

Figure 1.5: Major ways in which models and scenarios can be used to inform agenda setting, policy design, policy implementation, and policy review. Models estimate or project changes in nature and nature's benefits as a function

of: observed changes in drivers, for status-and-trend assessment (green); plausible trajectories of drivers, for exploratory scenario analysis (red); possible policy interventions, for intervention scenario analysis (orange); or implemented policy interventions, for ex-post scenario analysis (blue).

Scenario analysis and modelling can inform and support activities across all four of these phases. As depicted in Figure 1.5, this involves using different types of scenarios of drivers and policy interventions as inputs to a common set of models for assessing the expected consequences of these scenarios for nature and nature's benefits. Various terminologies and typologies for describing and classifying these different types of scenarios have been proposed and used in the scenario literature (see for example: van Notten et al. (2003) and van Vuuren et al. (2012)).

This assessment deals primarily with two broad types of scenarios, referred to throughout this report as:

- **Exploratory scenarios** (also known in the literature as 'explorative scenarios' or 'descriptive scenarios') that examine a range of plausible futures, based on potential trajectories of drivers – either indirect (e.g., socio-political, economic and technological factors) or direct (e.g., habitat conversion, climate change).
- **Intervention scenarios** (also known in the literature as 'policy scenarios') that evaluate alternative policy or management options – either through **target seeking** (also known as 'goal seeking' or 'normative scenario analysis') or through **policy screening** (also known as 'ex-ante assessment').

Scenarios of a third broad type depicted in Figure 1.5 receive less attention in this assessment. These are policy-evaluation scenarios employed in ex-post assessments of the extent to which outcomes actually achieved by an implemented policy match those expected based on modelled projections, thereby informing policy review (see Chapter 3 for some further discussion of this scenario type).

1.3.2.1 Exploratory scenarios

Exploratory scenarios are employed mostly in the agenda-setting phase of the policy cycle. A sizeable proportion of previous efforts in scenario analysis and modelling of biodiversity and ecosystem services have used exploratory scenarios to identify and promote the need for action, and opportunities, to address detrimental changes in nature and its benefits.

This use of exploratory scenarios in agenda setting can add considerable value to the assessment of status and trends described in Section 1.2.3, by extending the focus of assessment from changes that are known to have already occurred past to present, to changes that might occur into the future (Pereira et al., 2010; Cook et al., 2014). At its most basic this extension may simply involve statistical extrapolation of observed trends in the state of biodiversity and ecosystem services into the future, assuming that levels or rates of change in underlying drivers will remain constant (e.g., Tittensor et al., 2014).

To more explicitly consider uncertainties in the future trajectories of drivers, exploratory scenarios are most commonly formulated as a discrete set of 'plausible futures', specified as narratives or storylines of economic and socio-political pathways, and including assumptions regarding, for example, technological development (Spangenberg et al., 2012). Formulation of plausible futures may involve the use of techniques such as horizon scanning to help identify future problems, threats, and opportunities at the margins of current thinking and planning (Cook et al., 2014). Examples of this general approach are the IPCC's Special Reports on Emission Scenarios (SRES), and similar sets of scenarios employed in the Millennium Ecosystem Assessment and the Global Environment Outlooks. In recent years, the plausible-futures approach has been increasingly complemented by alternative approaches to the development of exploratory scenarios. For example, 'probabilistic scenarios' can be developed using similar process-based models to those employed in modelling plausible futures, but using inputs drawn from probability distributions for each parameter based on best-available empirical data or expert knowledge, in place of discrete 'plausible' combinations of parameter values, thereby allowing probabilities to be attached to resulting projections (e.g., Abt Associates 2012).

1.3.2.2 Intervention scenarios

Moving from assessing the need for action in agenda setting, to actual decision making around specific actions in policy design and implementation, shifts the focus of scenario analysis and modelling from exploratory scenarios to intervention scenarios.

While the boundary between policy design and implementation is often rather fuzzy, the requirements for intervention scenarios at either ends of this spectrum can be quite different, especially in terms of the level of specificity, and spatial explicitness, with which potential actions are defined. This is particularly the case for policies allowing choice in the location of actions implemented under these policies – e.g., establishment of new protected areas to meet a high-level target (e.g., 17% of terrestrial area, as specified by Aichi biodiversity target 11), or allocation of funding under various economic instruments (e.g., an environmental stewardship scheme). In such situations, lower-level decisions made during the implementation of a high-level policy can have significant implications for the effectiveness of the outcome actually achieved by that policy – not just in biophysical terms, but also in terms of

implementation costs, and socio-economic consequences for people affected by these decisions. For example, decision-making around the precise location of new protected areas, or funded stewardship actions, may require spatially-explicit intervention scenarios at a much finer spatial resolution than those needed to inform the initial design of these high-level policies.

Two quite different strategies can be used to develop and evaluate intervention scenarios – target seeking, and policy screening (van Vuuren et al., 2012). Target seeking, in which a desired end-point or goal is first defined and analytical techniques such as backcasting (Dreborg, 1996) are then used to search for intervention scenarios that fulfil this goal, is being employed increasingly to inform high-level policy design (see Box 1.1 in Section 1.5.2 for an example of the application of this strategy, for the Rio+20 conference, by PBL (2012)). Policy screening, in which options for policy or management intervention are defined in advance and the relative effectiveness of these options is then evaluated through forecasting, is employed widely for both policy design and implementation (see Box 1.2 in Section 1.5.2 for an example of this strategy). These two strategies are discussed further in Section 1.4, and in Chapters 2 and 3.

The distinction between exploratory scenarios and intervention scenarios is often not as clear-cut as the above descriptions might suggest. Scenario analyses of biodiversity and ecosystem services are increasingly integrating elements of both exploratory and intervention scenarios within a single analysis.

The exploratory component of such analyses provides a means of addressing uncertainties associated with drivers that might affect the outcome of a given policy or decision-making process but are external to, and therefore not amenable to control or influence by, that process (Peterson et al., 2003). These drivers are therefore viewed as being ‘exogenous’ to the particular policy or decision context (Chermack, 2011). The intervention component then focuses on drivers that can be influenced by this particular process, and are therefore regarded as ‘endogenous’ or ‘policy-relevant’ (*ibid*). Exogenous drivers typically operate over broader spatial extents than those targeted by policy interventions addressing endogenous drivers (Figure 1.6). For example, in developing a national policy to protect or restore habitat to enhance the persistence of biodiversity under climate change, modelling of outcomes for biodiversity might be undertaken for integrated scenarios that pair alternative protection or restoration options at the national scale (the intervention component) with plausible climate futures at global or regional scales (the exploratory component) (Figure 1.6). This approach would thereby account for uncertainties associated with exogenous drivers of climate change when assessing policy options addressing endogenous drivers of habitat degradation.

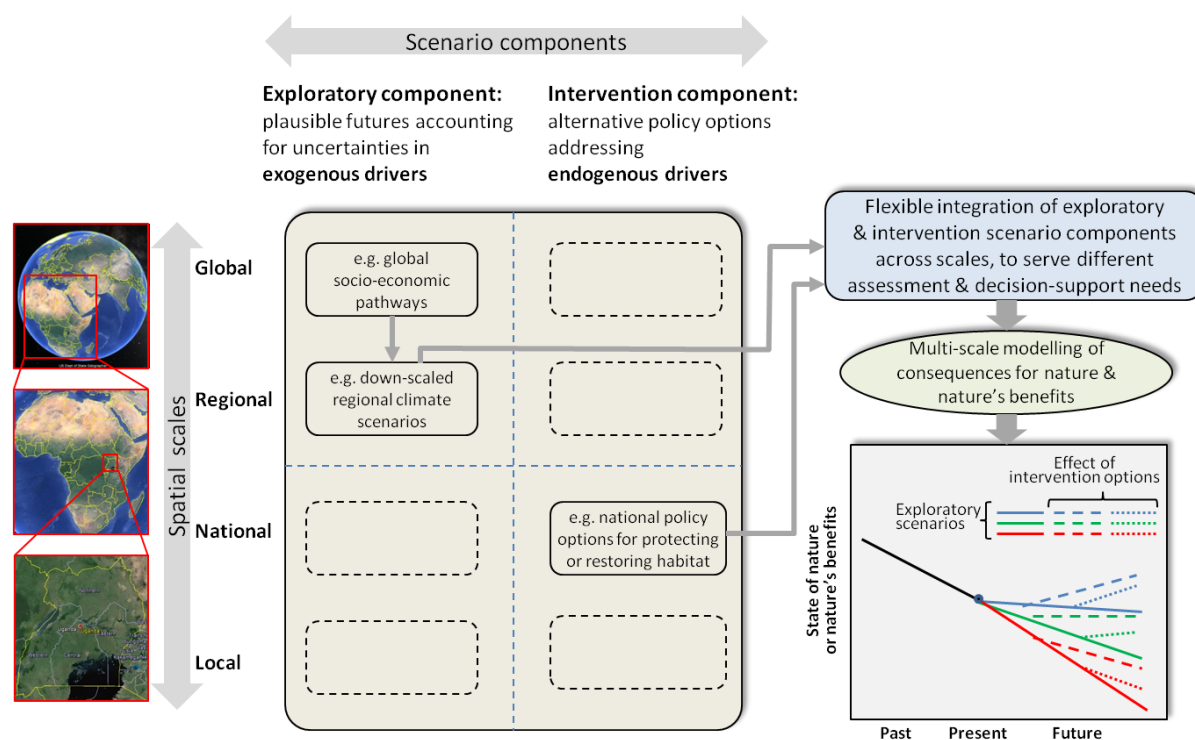

Figure 1.6: Scenario analyses are increasingly integrating elements of both exploratory scenarios and intervention scenarios within a single analysis. The exploratory component of such analyses accounts for uncertainties in ‘exogenous drivers’ – i.e., drivers that might affect the outcome of a given policy or decision-making process but are not amenable to influence by that process, and which typically operate at broader spatial scales. The intervention component focuses on alternative policy interventions addressing ‘endogenous drivers’. The particular components being combined in this diagram (illustrated by arrows leading from the centre panel to the top right box) serve to illustrate the example described in the text – i.e., the hypothetical design of a national policy to protect or restore habitat to enhance the persistence of biodiversity under climate change.

1.4 Linking scenarios and models to policy and decision making through assessment and decision-support interfaces

1.4.1 Overview

The interaction of policy and decision-making processes with scenarios and models will usually be mediated by some form of assessment or decision-support system or process, here referred to generically as an ‘interface’ (Figure 1.3). It is through this interface that high-level policy and decision-making needs are translated into explicit scenarios for analysis by appropriate models and, in turn, that outputs from this modelling are interpreted and communicated back to the world of policy and decision making.

The form and complexity of the interface needed for any given application depends very much on the precise nature of the policy or decision-making process being served, and particularly on the phase of the policy cycle being addressed (from section 1.3.2 above). For processes focused on agenda setting, this interface may simply involve selecting and formulating any exploratory scenarios to be assessed, managing the analysis of these scenarios using an appropriate set of models, and reporting results from these analyses in terms of projected outcomes for nature, or nature’s benefits to people. The interface employed in such situations will therefore often take the form of an ‘assessment’, typically communicating results in technical reports and/or published papers.

1.4.2 Decision-support interfaces

Managing the application of intervention scenarios to policy design and implementation, as opposed to agenda setting, often requires a shift from relatively static assessment to more dynamic, and interactive, decision support (see Chapter 2).

This is because the number of potential options for intervention can be very large, particularly within the policy-implementation phase – e.g., in terms of the examples from section 1.3.2.2, a large number of possible configurations of protected areas, or of funded stewardship actions.

If all possible options of interest are known at the outset of a decision-making process then various forms of mathematical (computer-based) optimisation might be used to automate the search for an intervention, or set of interventions, that either maximises the expected outcome for nature or nature’s benefits, or maximises the robustness of this outcome in the face of future uncertainties (Williams and Johnson, 2013). However, many policy design and implementation processes – especially at lower (more local) levels of decision-making – require consideration of intervention options that are not necessarily known in advance, but instead arise dynamically from interactions and negotiations within the process itself. This means that intervention scenarios must be formulated, and analysed, progressively throughout the decision-making process. Searching for, and reaching agreement on, effective policy or management interventions in such situations becomes more a process of interactive trial-and-error, involving adaptive evaluation and modification of intervention scenarios informed by feedback on the modelled consequences of these options. Growing recognition since the 1970s (Holling, 1978) of this need for more interactive, and inclusive, involvement of decision-makers and stakeholders in the formulation and evaluation of intervention scenarios is reflected in the recent proliferation of planning approaches, both qualitative and quantitative, based around ‘participatory scenarios’ (Walz et al., 2007; Sandker et al., 2010; Priess and Hauck, 2014).

The basic idea of using models to evaluate consequences of intervention scenarios, as a foundation for decision making, is already well established within several existing methodological paradigms or frameworks including, for example: ‘management strategy evaluation’ (De la Mare, 1998; Fulton et al., 2014), ‘structured decision making’ (Addison et al., 2013), ‘scenario planning’ (Peterson et al., 2003), and ‘strategic foresight’ (Cook et al., 2014) (see Chapter 2 for a comprehensive review of such approaches). Tools associated with these, and related, paradigms are often called upon to fulfil the decision-support interface role depicted in Figure 1.3. Linking such tools with scenarios and models offers a highly structured, and potentially very effective, means of implementing the target-seeking and policy-screening strategies introduced in Section 1.3.2.2, for developing and evaluating options for policy or management intervention.

1.4.3 Embedding scenarios and models of nature and nature’s benefits within broader cross-sectoral assessment and decision support

In many policy or decision contexts, the consequences of exploratory and intervention scenarios will need to be evaluated in terms of impacts on multiple values or objectives. These might include different values associated with nature (e.g., multiple biodiversity or ecosystem attributes) or nature’s benefits (e.g., multiple ecosystem services). If impacts on such values have been projected using multiple models then the assessment and decision-support interface (depicted in Figure 1.3) may also need to play an important role in aggregating and synthesising modelled outcomes across these values. Various levels of rigour and sophistication can be employed in this integration, ranging from relatively simple visualisation techniques through to more mathematical approaches such as multi-criteria analysis (Arhonditsis et al., 2002).

The breadth of values and objectives to be considered in policy and decision making will often extend well beyond those directly associated with, or mediated by, nature and nature's benefits. This is likely to be the case for many, if not most, assessment and decision-support processes addressing overall human well-being, and therefore quality of life (e.g., Hatfield-Dodds et al., 2015). As already indicated in Section 1.2.2.1 such processes may require results from modelling of nature and nature's benefits to be integrated with modelling of other major dimensions of human well-being – e.g., education, health, energy – undertaken within other domains or sectors (as represented by the 'cross-sectoral integration' element in Figure 1.3). Techniques such as multi-criteria analysis can again play a crucial role in aggregating modelled outcomes across broader sets of values into composite indices of human well-being (e.g., Ding and Nunes, 2014). However, it should be recognised that this level of cross-sectoral integration may often be driven and managed by assessment and decision-support processes external to, or transcending, the domain of IPBES.

In many cases, modelling of consequences of scenarios for nature and nature's benefits, undertaken by communities of practice associated with IPBES, will need to feed into higher-level processes assessing implications for human well-being across a broader range of values and objectives.

Demand for this level of cross-sectoral integration is set to escalate following recent ratification of the United Nation's (UN) Sustainable Development Goals (<https://sustainabledevelopment.un.org/>; see also Chapters 2, 5 and 6). The SDGs, now agreed to by member states of the UN, have ushered in a new set of universal goals and targets ranging from poverty eradication to sustainable management of natural resources, to be achieved by 2030. In the SDGs, unlike the previous Millennium Development Goals, both nature and nature's benefits have been recognised as making important contributions to human well-being, and at least six of the 17 SDGs are directly linked to aspects of biodiversity and ecosystem services. Scenario analysis and modelling across multiple sectors are likely to play a vital role in monitoring progress in relation to the SDGs, and to ensuring that effective policy instruments and institutional frameworks are put in place to meet the associated targets.

Any use of scenarios and models to inform policy and decision making will typically take place within a much broader, and often highly complex, social, economic and institutional context (Figure 1.3). Policy design and implementation will rarely, if ever, be driven by scenario analysis and modelling alone.

It is therefore important to recognise from the outset of this assessment that guidance provided by scenarios and models will nearly always constitute just one of a number of inputs and considerations shaping policy and management decisions. In addition, the relationships between scenarios, modelling and decision-making are often more complex than Figure 1.3 depicts, and can involve highly dynamic interactions and feedbacks between scenario and model development, knowledge and data generation, and engagement with decision makers (see Chapter 8 for a more detailed discussion).

1.5 Combining scenarios, models and interfaces in different ways to serve diverse policy and decision-making needs

1.5.1 Tailoring approaches for particular policy or decision contexts

From the scene-setting introductions to models, scenarios and decision-support interfaces provided in Sections 1.2, 1.3 and 1.4 it is clear that a considerable diversity of approaches, and of options for applying these approaches, exists across all of these components. How can policy practitioners and scientists seeking to use scenarios and models to inform policy and decision making around nature and nature's benefits choose an appropriate solution from the many alternatives on offer?

An important message emerging from this assessment, and recurring across all chapters of this report, is that the appropriateness of different methodological approaches and options depends very much on the characteristics and needs of any particular policy or decision-making process – i.e., the 'policy or decision context'.

It is therefore vital that approaches employed in different contexts are tailored carefully to the needs of those contexts. No single solution can serve all needs, and different contexts will often require very different solutions.

Figure 1.7 depicts important characteristics and needs of policy and decision-making processes that are likely to vary markedly between contexts. This figure also depicts choices in the selection or design of scenarios, models, and decision-support interfaces, which are dependent on these policy-context characteristics. While many of these dependencies have already been touched on in previous sections they are synthesised in Figure 1.7, and further summarised below, to provide readers with a better sense of the overall challenge in ensuring that employed approaches are well matched to the needs of particular policy or decision contexts.

Phase of the policy cycle

Activities aligned with different phases of the policy cycle require the use of different types of scenarios, and different types of assessment or decision-support interfaces. For example, processes focused on agenda setting typically require the use of exploratory scenarios, whereas those focused on policy design or implementation are instead likely to require intervention scenarios (see Section 1.3 and Chapter 3). The interfacing of scenarios and models with agenda

setting will often simply take the form of a relatively simple, static assessment in which expected outcomes for nature or nature's benefits are modelled for a discrete set of exploratory scenarios, and then documented in a report or publication. On the other hand, the interfacing of scenarios and models with policy design and implementation is more likely to require the use of structured, and often dynamic, decision-support tools to help manage and evaluate large numbers of intervention options (see Section 1.4; Chapter 2).

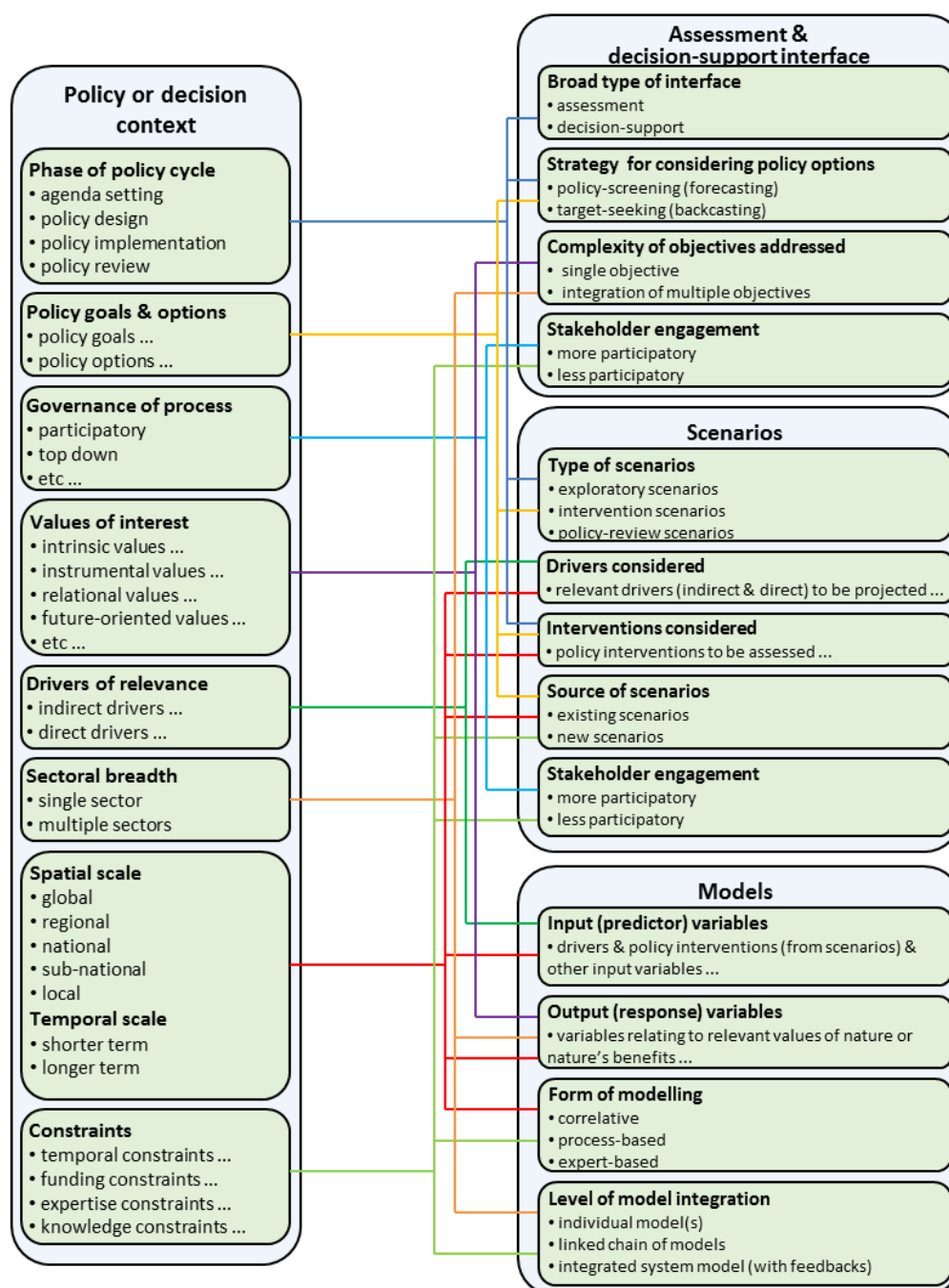

Figure 1.7: Dependencies between the characteristics and needs of policy and decision-making processes in different contexts, and the selection or design of scenarios, models, and decision-support interfaces to serve these needs. Each coloured line indicates that the selection or design of a particular attribute of ‘Assessment & decision-support interface’, ‘Scenarios’, or ‘Models’ (right side of figure) is dependent on a particular characteristic or need of the ‘Policy or decision context’ (left side of figure).

Policy goals and options

The way that goals and options are defined in any given policy design or implementation process has a strong bearing on the appropriateness of target-seeking versus policy-screening strategies for developing and evaluating intervention scenarios (see Sections 1.3 and 1.4; Chapters 2 and 3). Processes focused on identifying possible policy pathways for achieving a clearly defined target, or set of targets (e.g., the Convention on Biological Diversity's (CBD) Aichi biodiversity targets, or targets associated with the Sustainable Development Goals), are likely to be best served

through employment of a target-seeking strategy. Other processes may, however, simply involve choosing between a set of pre-defined policy or management options, and are therefore better served through policy-screening.

Spatial and temporal scale

Activities across all policy-cycle phases can occur at a wide range of spatial scales – global, regional, national, sub-national and local. The spatial extent (coverage) and resolution (grain or detail) of scenarios and models employed in any policy or decision-making process must therefore be aligned carefully with the scale of interest for that process. Such processes can also address quite different temporal scales of concern – ranging from processes focused on short-term outcomes (changes made over a few years) through to those focused on achieving longer-term change (e.g., over several decades) – which again has strong implications for the temporal scale of any scenarios and models employed (see Sections 1.2 and 1.3; Chapters 2 to 8).

Values of interest

The focus placed on different values associated with nature, or nature's benefits to people, varies markedly across policy and decision contexts. The IPBES Conceptual Framework (Díaz, 2015) recognises that such values can be of many different types, and this diversity is further described and explored in the draft 'Preliminary guide regarding diverse conceptualization of multiple values of nature and its benefits, including biodiversity and ecosystem functions and services' prepared by IPBES Deliverable 3d. That guide defines several major types of values of relevance to IPBES activities: instrumental, non-instrumental, anthropogenic, anthropocentric, non-anthropocentric, relational, intrinsic, biophysical, economic and socio-cultural values. It also highlights the importance of future-oriented values associated with nature, and particularly with biodiversity, including bequest, insurance and option values. Any particular policy or decision-making process is likely to focus on a subset, and often a very narrow subset, of all these possible values. Models used to translate exploratory and intervention scenarios into expected consequences for nature and nature's benefits therefore need to be chosen carefully to ensure that response (output) variables projected by these models align well with the values of concern in a given process (see Section 1.2; Chapters 2, 4, and 5). The type and number of values being considered also has implications for the form of assessment or decision-support interface employed – e.g., whether multiple values need to be combined through multi-criteria analysis or visualisation (see Section 1.4; Chapter 2).

Drivers of relevance

The drivers, both indirect and direct, that need to be considered in a given policy or decision-making process will depend partly on the policy goals and options, spatial scale, temporal scale, and particular values of nature or nature's benefits, being addressed by that process. Some processes may also choose to focus attention on a subset of drivers, or just one particular driver – e.g., climate change, habitat loss, or invasive species – rather than attempting to address all drivers of potential relevance in a given context. This clearly has important implications for the choice of drivers to be projected by scenarios, and in turn used as inputs to models translating these scenarios into expected consequences for nature and nature's benefits (see Sections 1.2 and 1.3; Chapters 3, 4 and 5).

Sectoral breadth of process

Some policy and decision-making processes will focus exclusively on objectives relating to nature or nature's benefits to people. However, many other processes will involve consideration of a broader range of environmental, social and economic objectives, of which only a subset relates directly to nature or its benefits. Such processes are likely to require that results of any scenario analysis and modelling of nature and nature's benefits are integrated with modelling of other dimensions of human well-being, undertaken across multiple sectors (e.g., health, education, energy) (see Section 1.4; Chapters 2, 3, 5, 6 and 8).

Governance of process

Differences in governance of policy and decision-making processes can also have important implications for the appropriateness of alternative approaches to scenario analysis and decision support – e.g., the appropriateness of participatory approaches will depend on the extent to which the policy process is itself participatory, or instead top down, in nature (see Section 1.4; Chapters 2, 7 and 8).

Constraints on available time, funding, expertise, knowledge and data

Finally, all policy and decision-making processes are bound, to varying degrees, by constraints relating to the availability of time, funding and expertise for undertaking associated assessment or decision-support activities, and of knowledge and data to inform these activities. Such constraints can place strong limits on the level of rigour and sophistication that can be achieved in developing and using scenarios and models in any given context, including for example: potential scope to develop new scenarios, as opposed to making use of existing scenarios from previous processes; level of involvement of stakeholders in any such development (e.g., through participatory approaches); and employment of highly integrated process-based modelling techniques as opposed to simple correlative or expert-based models (see Sections 1.2, 1.3 and 1.4; Chapters 2 to 8).

1.5.2 Effective use of scenarios and models in previous assessments and decision-support activities

Scenarios and models of biodiversity and ecosystem services have already been employed effectively in a wide range of assessments informing agenda setting, and in decision-support activities informing policy design and implementation. Table 1.1 provides details of selected examples of these applications at global, regional and national scales.

Table 1.1

Selected examples of previous applications of scenarios and models of biodiversity and ecosystem services to agenda setting, policy design and implementation at global, regional and national scales

	Global Biodiversity Outlook 4 (2014)	IPCC 5th Assessment Report, WG II and III (2014)	Millennium Ecosystem Assessment (2005)	United Kingdom National Ecosystem Assessment (2011)	Strategic environmental assessment of hydropower on the Mekong mainstream	South African fisheries management
Spatial Scale	Global	Global	Global	National: United Kingdom	Regional: Analysis covers Cambodia, China, Laos, Thailand and Vietnam	National: Coastal fisheries of South Africa
Time horizons	Present–2020, 2050	2050, 2090	2050	2060	2030	Present–2034 updated every 2–4 years
Position in policy cycle	Agenda setting, policy formulation	Agenda setting	Agenda setting	Agenda setting	Policy formulation and implementation	Policy implementation
Authorizing environment	Assessment requested by member countries of the Convention on Biological Diversity (CBD)	Assessment requested by member countries of the IPCC	Initiated by scientific community, then welcomed by the United Nations	Recommended by the United Kingdom House of Commons as a follow-up to the Millennium Ecosystem Assessment	Strategic environmental assessment (SEA) carried out for the Mekong River Commission	Evaluation carried out by the South African Department of Agriculture, Forestry and Fisheries
Issues addressed using scenarios and models	<ul style="list-style-type: none"> Are the Aichi Biodiversity Targets likely to be attained by 2020? What is needed to achieve the strategic vision for 2050 of the CBD? 	How might future climate change impact biodiversity, ecosystems and society?	What are plausible futures of biodiversity and ecosystem services?	What changes might occur in ecosystems, ecosystem services and values of these services over the next 50 years in the United Kingdom?	Evaluate social and environmental impacts of dam construction, especially in the main stream of the Mekong river	Implementation of policy on sustainable management of fisheries
Scenarios and models of direct and indirect drivers	<ul style="list-style-type: none"> Statistical extrapolations of trends in drivers up to 2020* Goal-seeking scenarios and models for analyses up to 2050 ("Rio+20 scenarios", see figure SPM.3) Analysis of a wide range of published exploratory and policy-screening scenarios at local to global scales 	<ul style="list-style-type: none"> Emphasis on exploratory scenarios (IPCC Special Report on Emissions Scenarios)* Strong focus on models of climate change as direct drivers, some use of associated land use scenarios. Some use of goal-seeking scenarios (Representative Concentration Pathways)* 	<ul style="list-style-type: none"> Exploratory scenarios using four storylines* Models of direct drivers from the IMAGE integrated assessment model* 	Exploratory scenarios using six storylines* <ul style="list-style-type: none"> Emphasis on land use and climate change drivers 	<ul style="list-style-type: none"> Policy screening scenarios using several dam development schemes <ul style="list-style-type: none"> Emphasis on economic growth and demand for electricity generation as main indirect drivers Climate change scenarios also assessed 	<ul style="list-style-type: none"> Goal-seeking scenarios <ul style="list-style-type: none"> focus on identifying robust pathways for sustainable catch
Models of impacts on nature	<ul style="list-style-type: none"> Statistical extrapolations of trends in biodiversity indicators up to 2020* Analysis of wide range of published correlative and process-based models <ul style="list-style-type: none"> Emphasis on impacts of a broad range of drivers on biodiversity 	Analysis of a wide range of published correlative and process-based models <ul style="list-style-type: none"> Emphasis on impacts of climate change on biodiversity and ecosystem functions 	Correlative models (e.g. species-area relationships) <ul style="list-style-type: none"> Emphasis on impacts of a broad range of drivers on biodiversity 	<ul style="list-style-type: none"> Correlative model of species response (birds) to land use Qualitative evaluation of impacts of land use and climate change on ecosystem functions <ul style="list-style-type: none"> Emphasis on habitat change as an indicator of environmental impacts 	<ul style="list-style-type: none"> Estimates of habitat conversion based on dam heights, habitat maps and elevation maps Estimates of species level impacts based on dam obstruction of fish migration and on species habitat relationships 	<ul style="list-style-type: none"> Population dynamics models of economically important fish Recently added models of indirectly impacted species (e.g. penguins) Use of ecosystem-based models under consideration
Models of impacts on nature's benefits	Analysis of published studies <ul style="list-style-type: none"> Focus on ecosystem services from forests, agricultural systems and marine fisheries Little evaluation of direct links to biodiversity 	Analysis of wide range of published studies <ul style="list-style-type: none"> Little evaluation of direct links to biodiversity except in marine ecosystems 	Estimates of some ecosystem services (e.g., crop production, fish production) from the IMAGE integrated assessment model	<ul style="list-style-type: none"> Qualitative and correlative models of ecosystem services Focus on correlative methods for estimating monetary value <ul style="list-style-type: none"> Emphasis on monetary valuation, except for biodiversity value 	<ul style="list-style-type: none"> Empirical estimates of fisheries impacts based on reduced migration, and changes in habitat Diverse methods to estimate changes in water flow and quality, sediment capture, cultural services, etc. 	Estimates of total allowable catch based on fish population models

	Global Biodiversity Outlook 4 (2014)	IPCC 5th Assessment Report, WG II and III (2014)	Millennium Ecosystem Assessment (2005)	United Kingdom National Ecosystem Assessment (2011)	Strategic environmental assessment of hydropower on the Mekong mainstream	South African fisheries management
Participation of stakeholders	<ul style="list-style-type: none"> Debate and approval by member countries of the CBD Dialogues between scientists and the secretariat and delegates of the CBD during assessment process 	<ul style="list-style-type: none"> Debate and approval by member countries of the IPCC Little involvement of stakeholders in scenarios development 	Dialogs with stakeholders during scenario development	<ul style="list-style-type: none"> Consultation of stakeholders during scenario development Adopted by "Living With Environmental Change" partnership of government and non-government stakeholders 	Extensive dialog involving multiple governments, expert workshops, and public consultations	Consultation between government, scientists and stakeholders during development of management strategy and setting of total allowable catch
Decision support tools	None	None	None	None, but tools under development	Strategic Environmental Assessment methods (see chapter 2)	Management Strategy Evaluation (see chapter 2)
Outcomes	Extrapolations may have contributed to member countries of the CBD making non-binding commitments in 2014 to increase resources for biodiversity protection	Key documents underlying negotiations of UNFCCC. Commitments of countries to climate mitigation to be discussed Dec 2015	Increased awareness of the potential for substantial future degradation of biodiversity and ecosystem services	Contributed to Natural Environment White Paper and influenced the development of the biodiversity strategy for England	The Mekong River Commission recommended a ten-year moratorium on mainstream dam construction. However, 1 of 11 planned dams is under construction in Laos	Fisheries widely considered to be sustainably managed. Hake fishery is certified by the Marine Stewardship Council
Strengths	<ul style="list-style-type: none"> Novel use of extrapolations for near-term projections Clear decision context and authorizing environment 	<ul style="list-style-type: none"> Reliance on common scenarios and models of drivers provides coherence Clear decision context and authorizing environment 	One of the first global scale evaluations of future impacts of global change on biodiversity	Focus on synergies and trade-offs between ecosystem services and on monetary evaluation	<ul style="list-style-type: none"> Clear decision context and authorizing environment Strong involvement of stakeholders 	<ul style="list-style-type: none"> Clear decision context and authorizing environment Policy and management advice clear and updated regularly
Weaknesses	<ul style="list-style-type: none"> Focus on global scale limits applicability to many national and local decision contexts Lack of common scenarios and models of drivers makes analysis across targets difficult 	Emphasis on climate change, large spatial scales and distant time horizons limits usefulness for policy and management concerning biodiversity and ecosystems	<ul style="list-style-type: none"> Very limited set of scenarios and models explored Decision context unclear and authorizing environment weak 	<ul style="list-style-type: none"> Heavy reliance on qualitative estimates of impacts of drivers Biodiversity at species level weakly represented (only birds) 	<ul style="list-style-type: none"> Highly context-specific, especially the empirical models used, and therefore difficult to generalize or extrapolate to larger scales Mekong River Commission recommendations non-binding 	<ul style="list-style-type: none"> Highly context-specific Several key drivers (e.g., climate change) not considered
References	Secretariat of the Convention on Biological Diversity (2014), Kok et al. (2014), Leadley et al. (2014), Tittensor et al. (2014)	Fifth Assessment Report of Working Group II (2014) and III (2014) of the IPCC	Millennium Ecosystem Assessment (2005)	United Kingdom National Ecosystem Assessment (2011), Watson (2012), Bateman et al. (2013).	International Centre for Environmental Management (2010), chapter 2, ngm.nationalgeographic.com/2015/05/mekong-dams/nijhuis-text	Plaganyi et al. (2007), Rademeyer et al. (2007), chapter 2
Notes	* Methods developed for the Global Biodiversity Outlook 4	* Developed in support of the IPCC assessment process	* Developed for the Millennium Ecosystem Assessment	* Developed for United Kingdom National Ecosystem Assessment		

Two contrasting case studies are presented in more detail in Boxes 1.1 and 1.2, illustrating how scenarios and models have been combined effectively to address real-world assessment and decision-support needs at different scales and in different policy contexts.

The first of these (Box 1.1) employs target-seeking (back-casting) scenario analysis, combined with modelling of mean species abundance, to assess development pathways for achieving global sustainability goals. The second study (Box 1.2) was implemented at watershed scale in Thailand and uses policy-screening scenario analysis to evaluate the consequences of alternative land-use scenarios for the provision of ecosystem services, through modelling of impacts on water yield and sediment load.

Box 1.1: Case study – Rio+20 scenarios

Project Title	Rio+20 scenarios
Type of value	Global terrestrial and aquatic biodiversity
Driver	Human pressures
Temporal extent	Current to 2050
Spatial extent	Global
Model use	IMAGE, GLOBIO
Client	CBD, National governments

Multiple challenges, multiple targets

In 1992, governments worldwide agreed to work towards a more sustainable development that would eradicate poverty, halt climate change and conserve ecosystems. Although progress has been made in some areas, actions have not been able to alter the trends in other critical areas of sustainable development, such as providing access to sufficient food and modern forms of energy, preventing dangerous climate change, conserving biodiversity and controlling air pollution. Without additional effort, these sustainability objectives also will not be achieved by 2050.

Different pathways towards the targets

To jointly reach the long term targets on human well-being (eradicating hunger and ensuring full access to modern energy sources), climate change (temperature rising less than 2 °C) and biodiversity conservation (no further loss by 2050), three scenarios were developed. The long term targets for sustainability were the objective set for 2050 in these target-seeking scenarios (van Vuuren et al., 2012). The three scenarios were based on different strategies of sustainable development as follows (PBL, 2012):

Global Technology: focus on large-scale technologically optimal solutions, such as intensive agriculture and a high level of international coordination; for instance, through trade liberalization

Decentralized Solutions: focus on decentralized solutions, such as local energy production, agriculture that is interwoven with natural corridors and national policies that regulate equitable access to food

Consumption Change: focus on changes in human consumption patterns, most notably by limiting meat intake per capita, by ambitious efforts to reduce waste in the agricultural production chain and through the choice of a less energy-intensive lifestyle

These pathways towards the 2050 targets use different mixtures of policies to enhance productivity and reduce biodiversity loss (Figure Box 1.1), as well as different mixtures to enhance the use of modern energy and reducing climate change.

Models

The scenarios were evaluated up to 2050 using the IMAGE 3.0 (Integrated Model to Assess the Global Environment) modelling framework (Stehfest et al., 2014) (<http://themasites.pbl.nl/models/image>) combined with the GLOBIO 3.0 model (Alkemade et al., 2009) (<http://www.globio.info/>). IMAGE is an integrated assessment model of global environmental change, and enables assessment of the impacts of socio-economic development on the environment, including land use, climate and water flow and pollution. GLOBIO is linked to IMAGE and calculates the impacts of environmental changes on some biodiversity indicators by using cause-effect relationships.

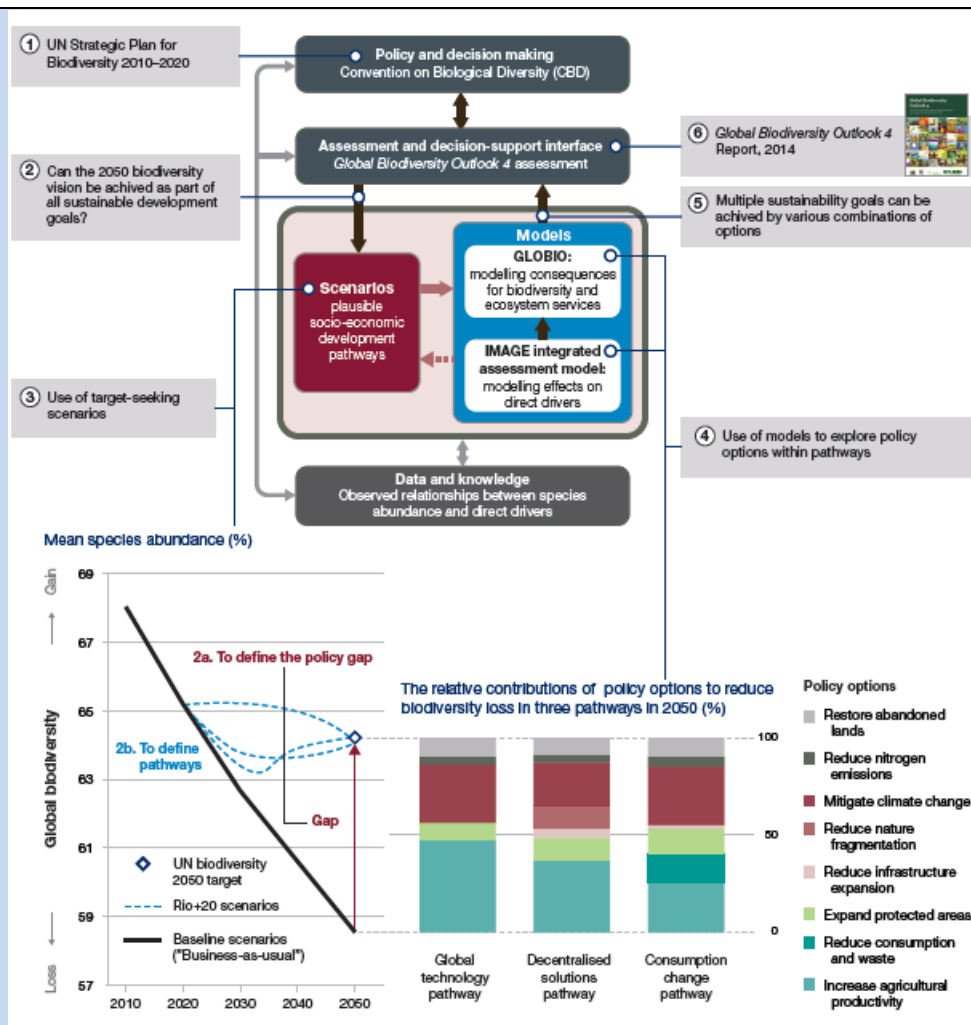

Figure Box 1.1: The bottom left-hand graph illustrates the differences between these pathways and a "business-as-usual" scenario in terms of impacts on global biodiversity (as measured by Mean Species Abundance). The right-hand graph indicates the contributions of different components of the three pathways. 'Policy gap' refers to the challenge for policy makers to achieve the goal (PBL, 2012).

The bottom left-hand graph illustrates how these scenarios differed from a "business-as-usual" scenario in terms of impacts on global biodiversity. The bottom right-hand graph shows the relative contributions of indirect drivers to halting biodiversity loss by 2050 compared to the "business-as-usual" scenario. The Global Biodiversity Outlook 4 report was an important factor in discussions at the 12th meeting of the Conference of the Parties to the Convention on Biological Diversity, which ended with additional commitments for action and funding to achieve the Aichi Biodiversity Targets. See chapter 1 for references.

The results of scenario analyses show that different combinations of policy actions, grouped in the three scenarios, may lead to achieving the multiple sustainability targets. These quantitatively coherent scenarios indicate that eradicating hunger as well as providing full access to modern energy, on the one hand, and achieving environmental sustainability, on the other, is possible. However, marginal improvements will not suffice; large, transformative changes are needed to realize sustainable development.

The role of the Rio+20 scenarios in policy support

Initially a contribution to the Rio+20 conference held in Rio de Janeiro in 2012, the scenarios and their main messages were taken up in the 4th Global Biodiversity Outlook (GBO4) (sCBD, 2014). The parties to the CBD adopted the conclusions of the GBO4, and committed to step up actions to achieve the Aichi biodiversity targets, including a pledge by national governments to double funding for necessary actions (CBD, <http://www.cbd.int/doc/press/2014/pr-2014-10-17-cop-12-en.pdf>). Additional initiatives were launched to enhance the biodiversity perspective in sustainable commodity production (CBD, <http://www.cbd.int/doc/press/2014/pr-2010-10-16-commodities-en.pdf>). The outcomes from the scenario analyses provided underlying arguments for these decisions and initiatives.

Box 1.2: Case study – Thadee watershed, Thailand

Project Title	Thadee watershed, Thailand
Type of value	Watershed services
Driver	Land-use change
Temporal extent	2009-2020
Spatial extent	Catchment (112 km²)
Model use	CLUEs, InVEST, RIOS
Client	Local stakeholders, local government

The Thadee watershed located in southern Thailand covers approximately 112 km². Water supply from the watershed is mainly used for agriculture by upstream farmers and household consumption by downstream people in the Nakhon Srithammarat municipality. However, natural forests in the watershed have been degraded and transformed to monocultures (fruit trees and rubber plantations) due to a governmental subsidy program. The ECO-BEST project co-funded by the EU, German Government (GIZ) and Thailand (Department of National Parks, Wildlife and Plant Conservation and Kasetsart University) worked with scientists to quantify water yield and sediment load according to different land use and rainfall scenarios during 2009-2020 (Trisurat, 2013). The CLUE-s (Conversion of Land Use and its Effects) model (Verburg and Overmars, 2009) was used to allocate future land demands based on two scenarios – agriculture development and conservation. In addition, InVEST (Integrated valuation of ecosystem services and trade-offs) (Nelson et al., 2009) and USLE (Universal Soil Loss Equation) models were employed to estimate water yield and soil erosion, respectively. The modelling results clearly show that intensifying land use change due to rapid expansion of rubber plantation and extreme rainfall will generate a high risk of major sediment loadings and overland water-flows due to the force of rainfall and decreased evapotranspiration from vegetation. With the application of an economic model RIOS (Resource Investment Optimization System) (RIOS, Vogl et al. (2013)), the project team together with stakeholders could identify which conservation activities (e.g., protection, reforestation and promotion of mixed-cropping system) should be implemented, and where, to yield the highest return on investments and to enhance watershed services. The municipality has agreed in principle to find the best practical mechanism for collecting payments from tap water clients and downstream, so called ‘payment for watershed services’, to implement the above activities.

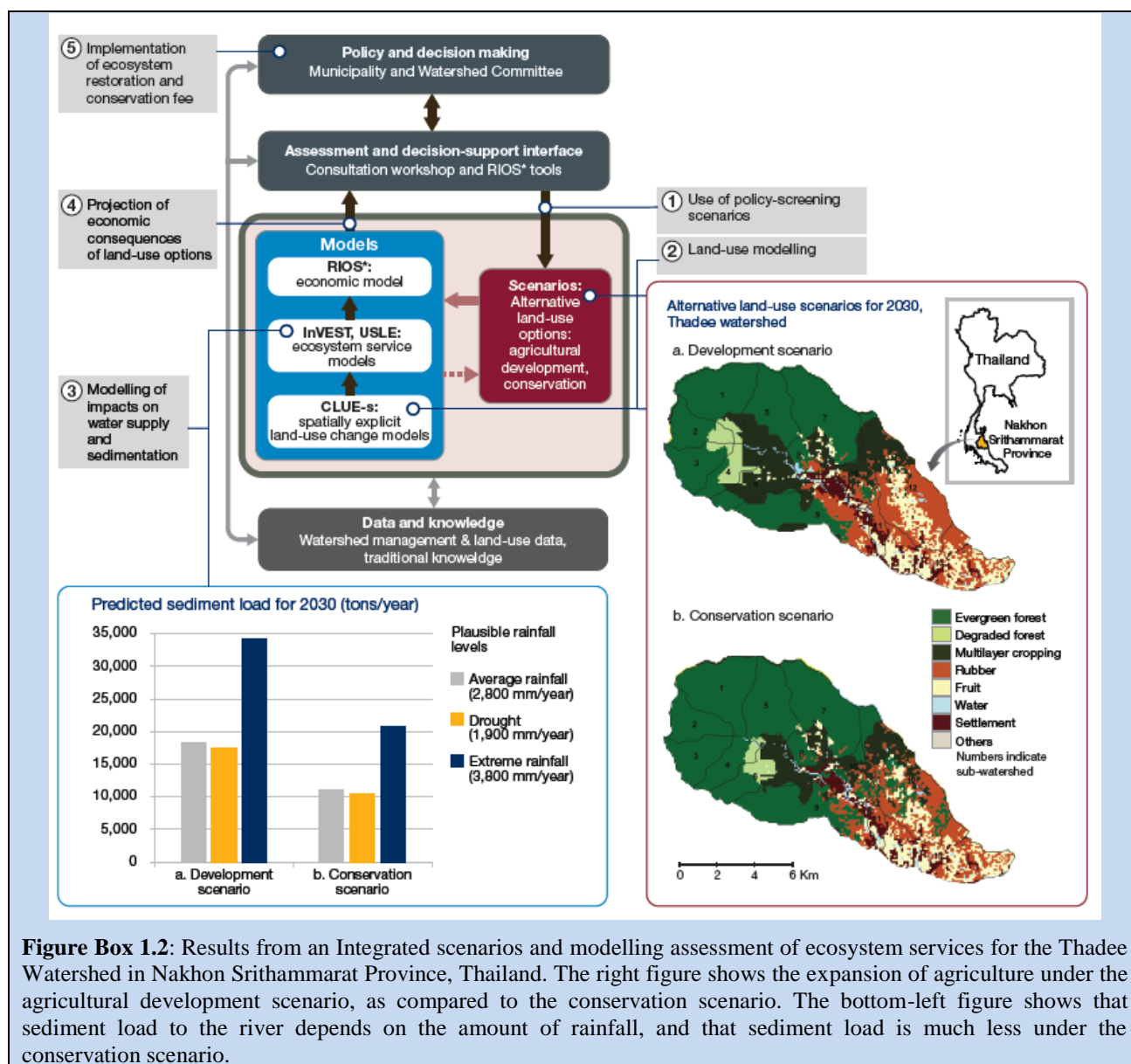

Figure Box 1.2: Results from an Integrated scenarios and modelling assessment of ecosystem services for the Thadee Watershed in Nakhon Srithammarat Province, Thailand. The right figure shows the expansion of agriculture under the agricultural development scenario, as compared to the conservation scenario. The bottom-left figure shows that sediment load to the river depends on the amount of rainfall, and that sediment load is much less under the conservation scenario.

1.6 Recognising and addressing current limitations of scenarios and models

Previous sections of this chapter have outlined the many ways in which scenarios and models of biodiversity and ecosystem services can contribute significantly across all phases of the policy cycle. But what are the challenges that need to be overcome to achieve broader application of these approaches? Identifying these challenges, and suggesting effective means of overcoming them, are themes that run throughout all chapters of this report. Some of the most important challenges relate to a general lack of understanding among policy and decision-making practitioners regarding the benefits of using scenarios and models (see Chapter 2), and a shortage of the human and technical resources needed to enable this use in many parts of the world (see Chapter 7). Various forms of capacity-building that could be used to address challenges of this type are described in Chapter 7. Other challenges are more technical in nature and concern limitations in currently available scenarios and models. While these limitations are also examined in depth throughout the remainder of the report (Chapters 2 to 6, and 8), three issues cutting across this discussion warrant introduction at this point.

1.6.1 Gaps in the focus and coverage of available scenarios and models

Section 1.5.1 stressed the importance of matching the types and characteristics of scenarios and models employed in any given policy or decision-making process to the needs of that process. Different processes often require very different types of scenarios and models, operating at different spatial and temporal scales, focusing on different ecosystems, addressing different sets of drivers and, in the case of models, projecting changes relating to different values of nature or nature's benefits (Figure 1.7).

Significant gaps currently exist in the availability of scenarios and models, and in methods for their derivation, to serve existing and emerging needs across the full range of policy and decision contexts.

Published studies of scenarios and models (as accessed for the graph presented in Figure 1.1) show a strong bias towards terrestrial ecosystems and towards climate change as the driver of interest. Nearer-term drivers such as habitat loss and modification, invasive species, pollution and overexploitation have received insufficient attention (FRB, 2013). Marine ecosystems are reasonably well represented, with many studies focusing on fisheries management or climate-change impacts on marine biodiversity and ecosystems (e.g., Dunstan et al., 2011; Sumaila et al., 2011). Freshwater ecosystems are under-represented in existing analyses compared to terrestrial ecosystems. Biodiversity models are heavily biased towards the species level followed by community-level studies, with relatively few models addressing the genetic level. Animals and plants are represented roughly equally, but micro-organisms are infrequently addressed. There is also a strong bias of scenarios and models towards mid- and end-21st century outcomes (FRB, 2013), whereas many managers and policy makers are more focused on nearer terms goals (e.g., Aichi biodiversity targets for 2020, sCBD, 2014). Comparisons of modelled outcomes in the past to observations are also rare, even though these could strengthen confidence in future projections. Spatial scales of scenarios and models employed in assessments typically focus on national to global scales. Few assessments account for the vast amount of information from scenarios and models applied at sub-national scale, which is a more pertinent spatial scale for many decision-making processes. Finally, in relation to ecosystem services, the scenarios and models employed in most assessments have rarely dealt with services outside of food production and carbon storage (but see UK NEA, 2011; PBL, 2012), even though other types of ecosystem services are often key considerations in decision-making.

1.6.2 Deficiencies in underpinning knowledge and data

Most models build on established knowledge and data to describe relationships of interest. Data are used to guide the design of models, calibrate model parameters, and validate predicted outcomes.

The effectiveness of scenario analysis and modelling in informing policy and decision making depends on the relevance, quality, quantity and availability of data and knowledge (scientific, indigenous, and local). Modelling does not replace the need for good data and knowledge, but instead provides a means of extracting maximum value from best-available information at any point in time.

The quality of modelled outputs for use in assessments and decision support will always be constrained by the quality and quantity of underpinning information. The importance of linking future applications of scenario analysis and modelling with ongoing efforts and initiatives around gap-filling data collection and knowledge acquisition is addressed in depth by Chapter 8. The importance placed by IPBES on this issue is also reflected by the establishment of two key activities under the IPBES Work Programme: the Task Force on Knowledge and Data Generation; and the Task Force on Indigenous and Local Knowledge (ILK).

This methodological assessment includes particular consideration (in Chapters 5 and 7) of the contribution that indigenous and local knowledge can make to filling information gaps, and to enabling successful application of scenarios and models to policy and decision making, including through the use of participatory approaches to scenario and model development. For example, mobilization of ILK through participatory approaches can help to ensure that indigenous peoples have an integral and meaningful role in making decisions, and in contributing to natural resource management, affecting their future, either directly or indirectly (Emery, 2000). In terms of scenarios and models, this knowledge is crucial in order to accommodate fundamental aspects of day-to-day life, and of cultural complexes that also encompass language, systems of classification, resource use practices, social interactions, ritual, and spirituality. Combining ILK with scientific knowledge will, in many cases, lead to greater benefits than can be achieved by treating these knowledge sources separately (Thaman et al., 2013).

1.6.3 Challenges in dealing with uncertainty

The term ‘uncertainty’ appears repeatedly throughout all remaining chapters of this assessment report. To properly appreciate the importance, and varied implications, of this issue for the discussion and use of scenarios and models, it is vital to first recognise that uncertainty can take a diversity of forms, arising from very different sources. Various typologies of uncertainty have been proposed in the environmental-sciences literature (e.g., Regan et al., 2002; Skinner et al., 2014). For the purposes of this report, four major sources of uncertainty are recognised:

- **Linguistic uncertainty** – imprecise meaning of words, including vagueness and ambiguity.
- **Decision uncertainty** – variation in subjective human judgments, preferences, beliefs, world views.
- **Stochastic uncertainty** (also known as ‘aleatoric uncertainty’) – random behaviour or unpredictability of complex natural, social and economic systems, particularly in relation to future states.
- **Scientific uncertainty** (also known as ‘epistemic uncertainty’) – imperfect knowledge or data on the system being described.

Each of these sources of uncertainty has particular implications for the description and use of scenarios and models. Throughout this report linguistic uncertainty is addressed largely through the careful definition of terms, including within the report’s glossary. Previous sections of this chapter have already introduced strategies for dealing with decision uncertainty – i.e., by ensuring that employed scenarios and models are well matched to different policy and

decision contexts, and that assessment and decision-support interfaces enable effective analysis of synergies and trade-offs between multiple values and objectives.

Stochastic uncertainty is the very challenge that exploratory scenarios are designed to address. The use of exploratory scenarios accepts that future trajectories of drivers of change in nature and nature's benefits will depend on events and actions that are yet to occur, and are highly unpredictable. This uncertainty is therefore accommodated through construction of a set of plausible futures, rather than a single future (see Chapter 3).

The purpose of exploratory scenarios is not to reduce stochastic uncertainty (which, by definition, cannot be reduced) but rather to convey realistic estimates of this source of uncertainty to policy and decision making (Enserink et al., 2013).

Scientific uncertainty associated with models used to translate scenarios into expected consequences for nature and nature's benefits need to be minimised as much as possible. However all models have limitations, and no model can generate perfect predictions. It is therefore highly desirable that levels of scientific uncertainty associated with model outputs are estimated, and accounted for effectively in decision making (see Chapter 2).

Scientific uncertainty is an unavoidable outcome of the very nature of models being simplifications of reality, and condensations of current knowledge. In the remainder of this report many shortcomings and gaps in models will be addressed. The most important of these gaps relate to: deficiencies in knowledge about key variables and relationships; loss of information when simplifying complex real-world systems to models; uncertainty in estimating the values of parameters and variables; lack of sufficient data of the right quality to validate models; and error propagation, especially within complex models.

1.7 Structure of this report

Methods for modelling different components of socio-ecological systems (i.e., elements of the IPBES Conceptual Framework) are increasingly being integrated within a single modelling framework (e.g., through so-called 'Integrated Assessment Models'). Likewise, the boundary between methods for modelling, and methods for scenario development, assessment and decision-making, is becoming increasingly fuzzy as a result of closer coupling of approaches across these domains. However, in the interests of breaking the overall challenge down into manageable pieces, Chapters 2 to 5 each focus, in turn, on a particular aspect or component of this challenge (Figure 1.8.). Linkages and dependencies between these topics, and the need for any given application of scenarios and models to consider these issues together, rather than sequentially, are emphasised throughout.

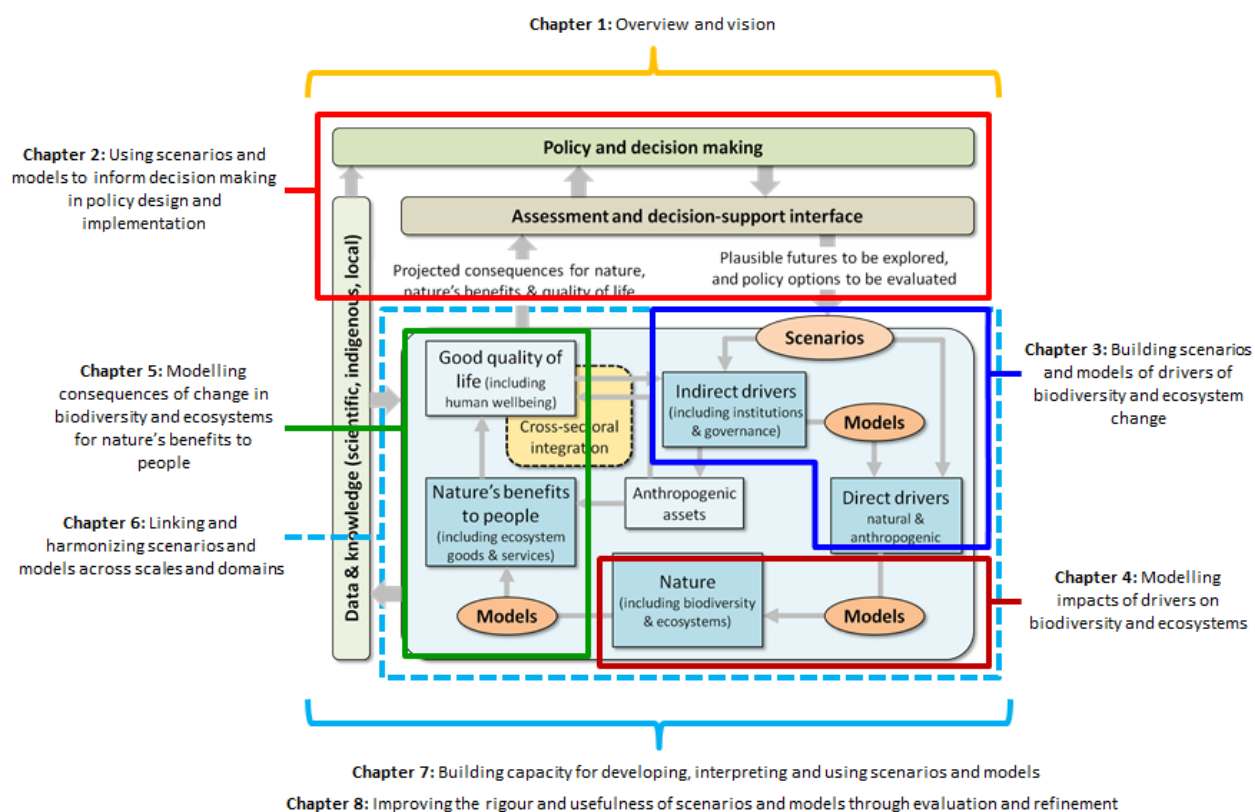

Figure 1.8: Relationship of chapters to the components depicted in Figure 1.3.

Chapter 2 examines issues around 'using scenarios and models to inform decision-making in diverse policy, planning and management contexts'. It provides an overview of policy, planning and management contexts in which scenarios

and models can aid assessment and decision-making, and considers lessons learnt from established decision-support paradigms and frameworks that make strong use of scenarios and models. Particular emphasis is placed on the importance of aligning the design of scenarios and models with the particular needs of assessment and decision-making processes associated with different phases of the policy cycle, and of dealing with uncertainty in scenarios and models employed in decision-making.

Chapter 3 addresses challenges associated with ‘building scenarios and models of indirect and direct drivers of change in biodiversity and ecosystems’ to address the assessment and decision-making needs identified in Chapter 2, and presents a typology of exploratory and intervention scenario sub-classes linked to major phases of the policy cycle. It reviews approaches to developing plausible scenarios of indirect drivers and lessons learnt from previous development and application of such scenarios in assessments at global and regional scales. It then reviews methods for modelling expected consequences of indirect-driver scenarios for direct drivers of change in biodiversity and ecosystems across terrestrial, freshwater and marine systems (as input to models of biodiversity and ecosystem responses considered in Chapter 4).

Chapter 4 deals with ‘modelling impacts of drivers on biodiversity and ecosystem properties and processes’. It explores existing and emerging approaches (both correlative and process-based) to modelling impacts of a broad range of direct drivers (from Chapter 3) on: biodiversity across multiple levels (e.g., population, species, community) and dimensions (e.g., composition, structure, function) of biological organisation; and ecosystem properties and processes (e.g., biomass, primary production).

Chapter 5 focuses on ‘modelling consequences of change in biodiversity and ecosystems for nature’s benefits to people’. It explores challenges associated with translating modelled biophysical changes in biodiversity and ecosystem properties and processes (from Chapter 4) into expected consequences for benefits to people (including ecosystem services), human well-being, and good quality of life. It emphasises the importance of recognising that different decision-making processes may require careful consideration of differences in the values that people involved in these processes place on, or derive from, nature.

The remaining chapters of the report explore, in greater depth, three particularly important cross-cutting challenges facing the ongoing development and application of scenario analysis and modelling from an IPBES perspective (Figure 1.8).

Chapter 6 articulates the need for better ‘linking and harmonising scenarios and models across scales and domains’ and proposes practical strategies and solutions for achieving this in both the short and longer term. These include approaches to: more closely linking and harmonising scenarios and models across different scales of assessment and decision-making; achieving closer coupling of scenarios dealing with different drivers, and models focusing on different dimensions or levels of biodiversity, or on different ecosystem functions or services (as covered separately in Chapters 3, 4 and 5).

Chapter 7 addresses the challenge of ‘building capacity for developing, interpreting and using scenarios and models’ by proposing practical strategies that account for regional and cultural diversity in perspectives on, and capacity for, scenario analysis and modelling. These include approaches to: improving regional and national access to, and training in, appropriate data-sets and software tools; developing methods for better incorporating local data and knowledge; and developing effective strategies for mainstreaming scenarios and models into assessment and decision-making processes across scales and across different policy, planning and management contexts.

Chapter 8 adopts a forward-looking perspective in addressing the challenge of ‘improving the rigour and usefulness of scenarios and models through ongoing evaluation and refinement’. It lays out a comprehensive vision and strategy for taking scenario analysis and modelling of biodiversity and ecosystem services to a whole new level of rigour, credibility and utility by: more closely linking this field to parallel initiatives in biodiversity/ecosystem data acquisition, and thereby establishing a rigorous foundation for ongoing model evaluation and calibration; and advancing the fundamental science underpinning development and application of scenarios and models through carefully prioritised research activities.

Each of the chapters includes a set of ‘Key findings’ and ‘Key recommendations’ at the start of the chapter. Key findings are general messages that arise from the critical analyses in this assessment and are aimed at a broad audience. Key recommendations are based on the key findings and more specifically address IPBES and experts involved in its deliverables. The key recommendations provide explanations of a wide range of actions that could be undertaken or stimulated by IPBES.

References

- Addison, P.F.E., Rumpff, L., Bau, S.S., Carey, J.M., Chee, Y.E., Jarrad, F.C., McBride, M.F. and Burgman, M.A., 2013: Practical solutions for making models indispensable in conservation decision-making. *Diversity and Distributions*, **19**(5-6): 490-502.
- Alkemade, R., Van Oorschot, M., Miles, L., Nellemann, C., Bakkenes, M. and ten Brink, B., 2009: GLOBIO3: A Framework to Investigate Options for Reducing Global Terrestrial Biodiversity Loss. *Ecosystems*, **12**(3): 374-390.
- Andrew, M.E., Wulder, M.A. and Nelson, T.A., 2014: Potential contributions of remote sensing to ecosystem service assessments. *Progress in Physical Geography*, **38**(3): 328-353.
- Arhonditsis, G., Karydis, M. and Tsirtsis, G., 2002: Integration of mathematical modeling and multicriteria methods in assessing environmental change in developing areas: A case study of a coastal system. *Journal of Coastal Research*, **18**(4): 698-711.
- Bateman, I.J., Harwood, A.R., Mace, G.M., Watson, R.T., Abson, D.J., Andrews, B., Binner, A., Crowe, A., Day, B.H., Dugdale, S., Fezzi, C., Foden, J., Hadley, D., Haines-Young, R., Hulme, M., Kontoleon, A., Lovett, A.A., Munday, P., Pascual, U., Paterson, J., Perino, G., Sen, A., Siriwardena, G., van Soest, D. and Termansen, M., 2013: Bringing Ecosystem Services into Economic Decision-Making: Land Use in the United Kingdom. *Science*, **341**(6141): 45-50.
- Bellard, C., Bertelsmeier, C., Leadley, P., Thuiller, W. and Courchamp, F., 2012: Impacts of climate change on the future of biodiversity. *Ecology Letters*, **15**(4): 365-377.
- Börner, K., Boyack, K.W., Milojevic, S. and Morris, S., 2012: An introduction to modeling science: Basic model types, key definitions, and a general framework for the comparison of process models. In *Models of Science Dynamics: Encounters Between Complexity Theory and Information Sciences*, Scharnhorst, A., Börner, K. and Van den Besselaar, P., eds., Berlin Heidelberg, Springer, 3-20.
- Brook, B.W., O'Grady, J.J., Chapman, A.P., Burgman, M.A., Akçakaya, H.R. and Frankham, R., 2000: Predictive accuracy of population viability analysis in conservation biology. *Nature*, **404**(6776): 385-387.
- Burgman, M., 2005: *Risks and Decisions for Conservation and Environmental Management*. Cambridge, Cambridge University Press.
- Butchart, S.H.M., Walpole, M., Collen, B., van Strien, A., Scharlemann, J.P.W., Almond, R.E.A., Baillie, J.E.M., Bomhard, B., Brown, C., Bruno, J., Carpenter, K.E., Carr, G.M., Chanson, J., Chenery, A.M., Csirke, J., Davidson, N.C., Dentener, F., Foster, M., Galli, A., Galloway, J.N., Genovesi, P., Gregory, R.D., Hockings, M., Kapos, V., Lamarque, J.-F., Leverington, F., Loh, J., McGeoch, M.A., McRae, L., Minasyan, A., Morcillo, M.H., Oldfield, T.E.E., Pauly, D., Quader, S., Revenga, C., Sauer, J.R., Skolnik, B., Spear, D., Stanwell-Smith, D., Stuart, S.N., Symes, A., Tierney, M., Tyrrell, T.D., Vie, J.-C. and Watson, R., 2010: Global Biodiversity: Indicators of Recent Declines. *Science*, **328**(5982): 1164-1168.
- Cardinale, B.J., Duffy, J.E., Gonzalez, A., Hooper, D.U., Perrings, C., Venail, P., Narwani, A., Mace, G.M., Tilman, D., Wardle, D.A., Kinzig, A.P., Daily, G.C., Loreau, M., Grace, J.B., Larigauderie, A., Srivastava, D.S. and Naeem, S., 2012: Biodiversity loss and its impact on humanity. *Nature*, **486**(7401): 59-67.
- Cheai, A., Badeau, V., Boe, J., Chuine, I., Delire, C., Dufrière, E., François, C., Gritti, E.S., Legay, M., Pagé, C., Thuiller, W., Viovy, N. and Leadley, P., 2012: Climate change impacts on tree ranges: model intercomparison facilitates understanding and quantification of uncertainty. *Ecology Letters*, **15**(6): 533-544.
- Chermack, T.J., 2011: *Scenario Planning in Organizations: How to Create, Use, and Assess Scenarios*. San Francisco, USA, Berrett-Koehler Publishers, Inc.
- Cook, C.N., Inayatullah, S., Burgman, M.A., Sutherland, W.J. and Wintle, B.A., 2014: Strategic foresight: how planning for the unpredictable can improve environmental decision-making. *Trends in Ecology & Evolution*, **29**(9): 531-541.
- Coreau, A., Pinay, G., Thompson, J.D., Cheptou, P.O. and Mermet, L., 2009: The rise of research on futures in ecology: rebalancing scenarios and predictions. *Ecology Letters*, **12**(12): 1277-1286.
- De la Mare, W.K., 1998: Tidier fisheries management requires a new MOP (management oriented paradigm). *Reviews in Fish Biology and Fisheries*, **8**: 349-356.
- De Vos, M.G., Janssen, P.H.M., Kok, M.T.J., Frantzi, S., Dellas, E., Pattberg, P., Petersen, A.C. and Biermann, F., 2013: Formalizing knowledge on international environmental regimes: A first step towards integrating political science in integrated assessments of global environmental change. *Environmental Modelling & Software*, **44**: 101-112.

- Díaz, S., Demissew, S., Joly, C., Lonsdale, W.M. and Larigauderie, A., 2015: A Rosetta Stone for nature's benefits to people. *PLoS Biology* **13**(1): e1002040.
- Ding, H.L. and Nunes, P., 2014: Modeling the links between biodiversity, ecosystem services and human wellbeing in the context of climate change: Results from an econometric analysis of the European forest ecosystems. *Ecological Economics*, **97**: 60-73.
- Dreborg, K.H., 1996: Essence of backcasting. *Futures*, **28**(9): 813-828.
- Dunstan, P.K., Foster, S.D. and Darnell, R., 2011: Model based grouping of species across environmental gradients. *Ecological Modelling*, **222**: 955-963.
- Elith, J. and Leathwick, J.R., 2009: Species distribution models: ecological explanation and prediction across space and time. *Annual Review of Ecology Evolution and Systematics* **40**: 677-697.
- Emery, A.R., 2000: Guidelines: Integrating Indigenous Knowledge in Project Planning and Implementation. The International Labour Organization, The World Bank, The Canadian International Development Agency, and KIVU Nature Inc., Quebec, Canada.
- Enserink, B., Kwakkkel, J.H. and Veenman, S., 2013: Coping with uncertainty in climate policy making: (Mis)understanding scenario studies. *Futures*, **53**: 1-12.
- Feld, C.K., Sousa, J.P., da Silva, P.M. and Dawson, T.P., 2010: Indicators for biodiversity and ecosystem services: towards an improved framework for ecosystems assessment. *Biodiversity and Conservation*, **19**(10): 2895-2919.
- Ferrier, S., 2011: Extracting more value from biodiversity change observations through integrated modeling. *Bioscience*, **61**(2): 96-97.
- FRB, 2013: Scenarios de la biodiversité: un état des lieux des publications scientifiques françaises. FRB (Fondation pour la Recherche sur la Biodiversité), Paris, France.
- Fulton, E.A., 2010: Approaches to end-to-end ecosystem models. *Journal of Marine Systems*, **81**(1): 171-183.
- Fulton, E.A., Smith, A.D.M., Smith, D.C. and Johnson, P., 2014: An Integrated Approach Is Needed for Ecosystem Based Fisheries Management: Insights from Ecosystem-Level Management Strategy Evaluation. *PLoS ONE*, **9**(1): e84242.
- Gordon, A., Wintle, B.A., Bekessy, S.A., Pearce, J.L., Venier, L.A. and Wilson, J.N., 2012: The use of dynamic landscape metapopulation models for forest management: a case study of the red-backed salamander. *Canadian Journal of Forest Research-Revue Canadienne De Recherche Forestiere* **42**: 1091-1106.
- Gritti, E.S., Gaucherel, C., Crespo-Perez, M.-V. and Chuine, I., 2013: How Can Model Comparison Help Improving Species Distribution Models? . *PLoS ONE*, **8**: e68823.
- Haines-Young, R., 2011: Exploring ecosystem service issues across diverse knowledge domains using Bayesian Belief Networks. *Progress in Physical Geography*, **35**(5): 681-699.
- Halpern, B.S., Longo, C., Hardy, D., McLeod, K.L., Samhouri, J.F., Katona, S.K., Kleisner, K., Lester, S.E., O'Leary, J., Ranelletti, M., Rosenberg, A.A., Scarborough, C., Selig, E.R., Best, B.D., Brumbaugh, D.R., Chapin, F.S., Crowder, L.B., Daly, K.L., Doney, S.C., Elfes, C., Fogarty, M.J., Gaines, S.D., Jacobsen, K.I., Karrer, L.B., Leslie, H.M., Neeley, E., Pauly, D., Polasky, S., Ris, B., St Martin, K., Stone, G.S., Sumaila, U.R. and Zeller, D., 2012: An index to assess the health and benefits of the global ocean. *Nature*, **488**(7413): 615-+.
- Harfoot, M., Tittensor, D.P., Newbold, T., McInerney, G., Smith, M.J. and Scharlemann, J.P.W., 2014a: Integrated assessment models for ecologists: the present and the future. *Global Ecology and Biogeography*, **23**(2): 124-143.
- Harfoot, M.B.J., Newbold, T., Tittensor, D.P., Emmott, S., Hutton, J., Lyutsarev, V., Smith, M.J., Scharlemann, J.P.W. and Purves, D.W., 2014b: Emergent Global Patterns of Ecosystem Structure and Function from a Mechanistic General Ecosystem Model. *PLoS Biology*, **12**(4): e1001841.
- Hatfield-Dodds, S., Schandl, H., Adams, P.D., Baynes, T.M., Brinsmead, T.S., Bryan, B.A., Chiew, F.H.S., Graham, P.W., Grundy, M., Harwood, T., McCallum, R., McCrea, R., McKellar, L.E., Newth, D., Nolan, M., Prosser, I. and Wonhas, A., 2015: Australia is 'free to choose' economic growth and falling environmental pressures. *Nature*, **527**(7576): 49-53.
- Holling, C., 1978: *Adaptive environmental assessment and management*. . London, UK, John Wiley & Sons Ltd.
- ICEM, 2010: MRC Strategic Environmental Assessment of hydropower on the Mekong mainstream. International Centre for Environmental Management Hanoi, Viet Nam.

- IEEP, Alterra, Ecologic, PBL and UNEP-WCMC, 2009: Scenarios and models for exploring future trends of biodiversity and ecosystem services changes. Final report to the European Commission, DG Environment on Contract ENV.G.1/ETU/2008/0090r. Institute for European Environmental Policy, Alterra Wageningen UR, Ecologic, PBL Netherlands Environmental Assessment Agency, United Nations Environment Programme World Conservation Monitoring Centre.,
- IPCC, 2014a: Climate Change 2014: Impacts, Adaptation, and Vulnerability. Part A: Global and Sectoral Aspects. Contribution of Working Group II to the Fifth Assessment Report of the Intergovernmental Panel on Climate Change. Cambridge University Press, [Field, C.B., V.R. Barros, D.J. Dokken, K.J. Mach, M.D. Mastrandrea, T.E. Bilir, M. Chatterjee, K.L. Ebi, Y.O. Estrada, R.C. Genova, B. Girma, E.S. Kissel, A.N. Levy, S. MacCracken, P.R. Mastrandrea, and L.L. White (eds.)], Cambridge, United Kingdom and New York, NY, USA.
- IPCC, 2014b: Climate Change 2014: Mitigation of Climate Change. Contribution of Working Group III to the Fifth Assessment Report of the Intergovernmental Panel on Climate Change. Cambridge University Press, [Edenhofer, O., R. Pichs-Madruga, Y. Sokona, E. Farahani, S. Kadner, K. Seyboth, A. Adler, I. Baum, S. Brunner, P. Eickemeier, B. Kriemann, J. Savolainen, S. Schlömer, C. von Stechow, T. Zwickel and J.C. Minx (eds.)], Cambridge, United Kingdom and New York, NY, USA.
- Kelly, R.A., Jakeman, A.J., Barreteau, O., Borsuk, M.E., ElSawah, S., Hamilton, S.H., Henriksen, H.J., Kuikka, S., Maier, H.R., Rizzoli, A.E., van Delden, H. and Voinov, A.A., 2013: Selecting among five common modelling approaches for integrated environmental assessment and management. *Environmental Modelling & Software*, **47**: 159-181.
- Kok, M., Alkemade, R., Bakkenes, M., Boelee, E., Christensen, V., Van Eerd, M., Van der Esch, S., Karlsson-Vinkhuyzen, S., Kram, T., Lazarova, T., Linderhof, V., Lucas, P., Mandryk, M., Meijer, J., Van Oorschot, M., L., T., Van Hoof, L., Westhoek, H. and Zagt, R., 2014: How Sectors can Contribute to Sustainable Use and Conservation of Biodiversity. Secretariat of the Convention on Biological Diversity, Montreal, Canada.
- Kuhnert, P.M., Martin, T.G. and Griffiths, S.P., 2010: A guide to eliciting and using expert knowledge in Bayesian ecological models. *Ecology Letters*, **13**(7): 900-914.
- Leadley, P., Pereira, H.M., Alkemade, R., Fernandez-Manjarrés, J.F., Proença, V., Scharlemann, J.P.W. and Walpole, M.J., 2010: Biodiversity Scenarios: Projections of 21st century change in biodiversity and associated ecosystem services. Secretariat of the Convention on Biological Diversity, Technical Series 50, Montreal.
- Leadley, P.W., Krug, C.B., Alkemade, R., Pereira, H.M., Sumaila, U.R., Walpole, M., Marques, A., Newbold, T., Teh, L.S.L., Van Kolck, J., Bellard, C., Januchowski-Hartley, S.R. and Mumby, P.J., 2014: Progress towards the Aichi Biodiversity Targets: An Assessment of biodiversity Trends, Policy Scenarios and Key Actions. Secretariat of the Convention on Biological Diversity, Technical Series 78, Montreal, Canada.
- Leutner, B.F., Reineking, B., Müller, J., Bachmann, M., Beierkuhnlein, C., Dech, S. and Wegmann, M., 2012: Modelling Forest α -Diversity and Floristic Composition — On the Added Value of LiDAR plus Hyperspectral Remote Sensing. *Remote Sensing*, **4**(9): 2818.
- MA, 2005: *Ecosystems and Human Well-being: Scenarios, Volume 2*. Washington, DC, Island Press.
- Mace, G.M., Collar, N.J., Gaston, K.J., Hilton-Taylor, C., Akçakaya, H.R., Leader-Williams, N., Milner-Gulland, E.J. and Stuart, S.N., 2008: Quantification of Extinction Risk: IUCN's System for Classifying Threatened Species; Cuantificación del Riesgo de Extinción: Sistema de la UICN para la Clasificación de Especies Amenazadas. *Conservation Biology*, **22**(6): 1424-1442.
- Nelson, E., Mendoza, G., Regetz, J., Polasky, S., Tallis, H., Cameron, D., Chan, K.M., Daily, G.C., Goldstein, J., Kareiva, P.M., Lonsdorf, E., Naidoo, R., Ricketts, T.H. and Shaw, M., 2009: Modeling multiple ecosystem services, biodiversity conservation, commodity production, and tradeoffs at landscape scales. *Frontiers in Ecology and the Environment*, **7**(1): 4-11.
- PBL, 2012: Roads from Rio+ 20: Pathways to achieve global sustainability goals by 2050. PBL Netherlands Environmental Assessment Agency, The Hague.
- Pereira, H.M., Leadley, P.W., Proença, V., Alkemade, R., Scharlemann, J.P.W., Fernandez-Manjarres, J.F., Araujo, M.B., Balvanera, P., Biggs, R., Cheung, W.W.L., Chini, L., Cooper, H.D., Gilman, E.L., Guénette, S., Hurtt, G.C., Huntington, H.P., Mace, G.M., Oberdorff, T., Revenga, C., Rodrigues, P., Scholes, R.J., Sumaila, U.R. and Walpole, M., 2010: Scenarios for Global Biodiversity in the 21st Century. *Science*, **330**(6010): 1496-1501.
- Pereira, H.M., Ferrier, S., Walters, M., Geller, G.N., Jongman, R.H.G., Scholes, R.J., Bruford, M.W., Brummitt, N., Butchart, S.H.M., Cardoso, A.C., Coops, N.C., Dulloo, E., Faith, D.P., Freyhof, J., Gregory, R.D., Heip, C.,

- Höft, R., Hurtt, G., Jetz, W., Karp, D.S., McGeoch, M.A., Obura, D., Onoda, Y., Pettorelli, N., Reyers, B., Sayre, R., Scharlemann, J.P.W., Stuart, S.N., Turak, E., Walpole, M. and Wegmann, M., 2013: Essential Biodiversity Variables. *Science*, **339**(6117): 277-278.
- Peterson, G.D., Cumming, G.S. and Carpenter, S.R., 2003: Scenario Planning: a Tool for Conservation in an Uncertain World. *Conservation Biology*, **17**(2): 358-366.
- Plagányi, É.E., Rademeyer, R.A., Butterworth, D.S., Cunningham, C.L. and Johnston, S.J., 2007: Making management procedures operational - innovations implemented in South Africa. *ICES Journal of Marine Science*, **64**(4): 626-632.
- Priess, J.A. and Hauck, J., 2014: Integrative Scenario Development. *Ecology and Society*, **19**(1): 14.
- Rademeyer, R.A., Plagányi, É.E. and Butterworth, D.S., 2007: Tips and tricks in designing management procedures. *ICES Journal of Marine Science*, **64**(4): 618-625.
- Regan, H.M., Colyvan, M. and Burgman, M.A., 2002: A taxonomy and treatment of uncertainty for ecology and conservation biology. *Ecological Applications*, **12**(2): 618-628.
- Ritchey, T., 2012: Outline for a Morphology of Modelling Methods. Contribution to a General Theory of Modelling. *Acta Morphologica Generalis*, **1**(1): 1-20.
- Rounsevell, M.D.A., Arneth, A., Alexander, P., Brown, D.G., de Noblet-Ducoudré, N., Ellis, E., Finnigan, J., Galvin, K., Grigg, N., Harman, I., Lennox, J., Magliocca, N., Parker, D., O'Neill, B.C., Verburg, P.H. and Young, O., 2014: Towards decision-based global land use models for improved understanding of the Earth system. *Earth Syst. Dynam.*, **5**(1): 117-137.
- Sandker, M., Campbell, B.M., Ruiz-Perez, M., Sayer, J.A., Cowling, R., Kassa, H. and Knight, A.T., 2010: The Role of Participatory Modeling in Landscape Approaches to Reconcile Conservation and Development. *Ecology and Society*, **15**(2): 16.
- sCBD, 2006: Global Biodiversity Outlook 2. Secretariat of the Convention on Biological Diversity, Montreal.
- sCBD, 2010: Global biodiversity Outlook 3. Montreal.
- sCBD, 2014: Global Biodiversity Outlook 4. Secretariat of the Convention on Biological Diversity, Montreal.
- Skinner, D.J.C., Rocks, S.A., Pollard, S.J.T. and Drew, G.H., 2014: Identifying Uncertainty in Environmental Risk Assessments: The Development of a Novel Typology and Its Implications for Risk Characterization. *Human and Ecological Risk Assessment*, **20**: 607-640.
- Spangenberg, J.H., Bondeau, A., Carter, T.R., Fronzek, S., Jaeger, J., Jylhä, K., Kühn, I., Omann, I., Paul, A., Reginster, I., Rounsevell, M., Schweiger, O., Stocker, A., Sykes, M.T. and Settele, J., 2012: Scenarios for investigating risks to biodiversity. *Global Ecology and Biogeography*, **21**(1): 5-18.
- Sparks, T.H., Butchart, S.H.M., Balmford, A., Bennun, L., Stanwell-Smith, D., Walpole, M., Bates, N.R., Bomhard, B., Buchanan, G.M., Chenery, A.M., Collen, B., Csirke, J., Diaz, R.J., Dulvy, N.K., Fitzgerald, C., Kapos, V., Mayaux, P., Tierney, M., Waycott, M., Wood, L. and Green, R.E., 2011: Linked indicator sets for addressing biodiversity loss. *Oryx*, **45**(03): 411-419.
- SSA, 2010: Satoyama - Satoumi Ecosystems and Human Well-being: Socio-ecological Production Landscapes of Japan – Summary for Decision Makers. United Nations University, Tokyo, Japan.
- Stehfest, E., Van Vuuren, D., Kram, T., Bouwman, L., Alkemade, R., Bakkenes, M., Biemans, H., Bouwman, A., Den Elzen, M., Janse, J., Lucas, P., Van Minnen, J., Müller, C. and Prins, A.G., 2014: *Integrated Assessment of Global Environmental Change with IMAGE 3.0. Model description and policy applications*. The Hague, PBL Netherlands Environmental Assessment Agency.
- Sumaila, U.R., Cheung, W.W.L., Lam, V.W.Y., Pauly, D. and Herrick, S., 2011: Climate change impacts on the biophysics and economics of world fisheries. *Nature Climate Change*, **1**(9): 449-456.
- Tallis, H., Mooney, H., Andelman, S., Balvanera, P., Cramer, W., Karp, D., Polasky, S., Reyers, B., Ricketts, T., Running, S., Thonicke, K., Tietjen, B. and Walz, A., 2012: A Global System for Monitoring Ecosystem Service Change. *Bioscience*, **62**(11): 977-986.
- Tett, P., Gowen, R.J., Painting, S.J., Elliott, M., Forster, R., Mills, D.K., Bresnan, E., Capuzzo, E., Fernandes, T.F., Foden, J., Geider, R.J., Gilpin, L.C., Huxham, M., McQuatters-Gollop, A.L., Malcolm, S.J., Saux-Picart, S., Platt, T., Racault, M.F., Sathyendranath, S., van der Molen, J. and Wilkinson, M., 2013: Framework for understanding marine ecosystem health. *Marine Ecology Progress Series*, **494**: 1-27.

- Thaman, R., Lyver, P., Mpande, R., Perez, E., Cariño, J. and Takeuchi, K., 2013: The contribution of indigenous and local knowledge systems to IPBES: Building Synergies with Science. IPBES Expert Meeting Report. UNESCO/UNU, Paris.
- Tittensor, D.P., Walpole, M., Hill, S.L.L., Boyce, D.G., Britten, G.L., Burgess, N.D., Butchart, S.H.M., Leadley, P.W., Regan, E.C., Alkemade, R., Baumung, R., Bellard, C., Bouwman, L., Bowles-Newark, N.J., Chenery, A.M., Cheung, W.W.L., Christensen, V., Cooper, H.D., Crowther, A.R., Dixon, M.J.R., Galli, A., Gaveau, V., Gregory, R.D., Gutierrez, N.L., Hirsch, T.L., Höft, R., Januchowski-Hartley, S.R., Karmann, M., Krug, C.B., Leverington, F.J., Loh, J., Lojenga, R.K., Malsch, K., Marques, A., Morgan, D.H.W., Mumby, P.J., Newbold, T., Noonan-Mooney, K., Pagad, S.N., Parks, B.C., Pereira, H.M., Robertson, T., Rondinini, C., Santini, L., Scharlemann, J.P.W., Schindler, S., Sumaila, U.R., Teh, L.S.L., van Kolck, J., Visconti, P. and Ye, Y., 2014: A mid-term analysis of progress toward international biodiversity targets. *Science*, **346**(6206): 241-244.
- Trisurat, Y., 2013: *Ecological Assessment: Assessing Condition and Trend of Ecosystem Service of Thadee watershed, Nakhon Si Thammarat Province (in Thai with English abstract). Final Report submitted to the ECO-BEST Project.* Bangkok, Faculty of Forestry, Kasetsart University.
- Turner, W., 2014: Sensing biodiversity. *Science*, **346**(6207): 301-302.
- UK NEA, 2011: *The UK National Ecosystem Assessment: synthesis of the key findings.* Cambridge, UK, UNEP-WCMC.
- UNEP, 2007: *Global Environment Outlook 4, environment for development.* Nairobi, Kenya, United Nations Environmental Programme
- UNEP, 2012: *Global Environment Outlook 5, Environment for the future we want.* Nairobi, Kenya, United Nations Environmental Programme
- Vackar, D., ten Brink, B., Loh, J., Baillie, J.E.M. and Reyers, B., 2012: Review of multispecies indices for monitoring human impacts on biodiversity. *Ecological Indicators*, **17**: 58-67.
- van Jaarsveld, A.S., Biggs, R., Scholes, R.J., Bohensky, E., Reyers, B., Lynam, T., Musvoto, C. and Fabricius, C., 2005: Measuring conditions and trends in ecosystem services at multiple scales: the Southern African Millennium Ecosystem Assessment (SAfMA) experience. *Philosophical Transactions of the Royal Society of London B: Biological Sciences*, **360**(1454): 425-441.
- van Notten, P.W.F., Rotmans, J., van Asselt, M.B.A. and Rothman, D.S., 2003: An updated scenario typology. *Futures*, **35**(5): 423-443.
- van Oijen, M., Reyer, C., Bohn, F.J., Cameron, D.R., Deckmyn, G., Flechsig, M., Härkönen, S., Hartig, F., Huth, A., Kiviste, A., Lasch, P., Mäkelä, A., Mette, T., Minunno, F. and Rammer, W., 2013: Bayesian calibration, comparison and averaging of six forest models, using data from Scots pine stands across Europe. *Forest Ecology and Management*, **289**: 255-268.
- van Vuuren, D.P., Kok, M.T.J., Girod, B., Lucas, P.L. and de Vries, B., 2012: Scenarios in Global Environmental Assessments: Key characteristics and lessons for future use. *Global Environmental Change*, **22**(4): 884-895.
- Verburg, P. and Overmars, K., 2009: Combining top-down and bottom-up dynamics in land use modeling: exploring the future of abandoned farmlands in Europe with the Dyna-CLUE model. *Landscape Ecology*, **24**(9): 1167-1181.
- Vogl, A., Tallis, H., Douglass, J., Sharp, R., Veiga, F., Benitez, S., Leon, J., Game, E., Petry, P., Guimeraes, J. and Lozano, J.S., 2013: Resource Investment Optimization System, Introduction & Theoretical Documentation. Natural Capital Project,
- Walz, A., Lardelli, C., Behrendt, H., Grêt-Regamey, A., Lundström, C., Kytzia, S. and Bebi, P., 2007: Participatory scenario analysis for integrated regional modelling. *Landscape and Urban Planning*, **81**(1): 114-131.
- Watson, R.T., 2012: The science–policy interface: the role of scientific assessments—UK National Ecosystem Assessment. *Proceedings of the Royal Society of London A: Mathematical, Physical and Engineering Sciences*, **468**(2147): 3265-3281.
- Williams, B.K. and Johnson, F.A., 2013: Confronting dynamics and uncertainty in optimal decision making for conservation. *Environmental Research Letters*, **8**(2): 025004.
- Wilson, L., Secades, C., Narloff, U., Bowles-Newark, N., Mapendembe, A., Booth, H., Brown, C. and Tierney, M., 2014: The Role of National Ecosystem Assessments in Influencing Policy Making. OECD Publishing, OECD Environment Working Paper,

Chapter 2 Using scenarios and models to inform decision making in policy design and implementation

Coordinating Lead Authors:

Lilibeth A. Acosta (Philippines), Brendan A. Wintle (Australia)

Lead Authors:

Zsófia Benedek (Hungary), Purna B. Chhetri (Bhutan), Sheila J Heymans (United Kingdom), Aliye Ceren Onur (Turkey), Rosario Lilian Painter (Bolivia), Andriamandimisoa Razafimpahanana (Madagascar), Kikuko Shoyama (Japan)

Contributing Authors:

Terry V. Walshe (Australia)

Review Editors:

Jennifer Hauck (Germany), Bojie Fu (China)

Purpose of this chapter: Provides an overview and typology of policy and decision-making contexts. Sets the scene for Chapters 3, 4 and 5 to identify the scenarios and models needed in these different contexts. Critically reviews major decision-support approaches for interfacing scenarios and models with policy and decision making.

Target audience: A broader, less technical audience for the overview of policy and decision-making contexts; but a more technical audience for the review of particular decision-support approaches.

Key findings

The decision context determines the most appropriate decision support tool for any situation. Decision context can be defined in terms of multiple attributes such as cultural and ecological complexity, temporal scale, and complexity of governance. A multitude of decision support tools and approaches exist that can be utilized at the decision-support interface to integrate information, address divergent stakeholder objectives and beliefs, and help deal with the many challenges and complexities facing decision makers. For every decision context, there are several decision support approaches and tools that may be appropriate. Decision support tools include scenarios, models of biodiversity and ecosystem services, and decision-making protocols, frameworks, and approaches such as multi-criteria decision analysis, numerical optimization, and integrative frameworks such as management strategy evaluation and structured decision making. Scenarios, models and decision support frameworks and protocols are used to help set the policy agenda, and support policy design, implementation and review. However, their influence on decisions is not always well documented.

Only a small proportion of decisions that impact on biodiversity and ecosystem services are explicitly considered environmental decisions, and a very low proportion of such decisions utilize scenarios, biodiversity and ecosystem services models and decision frameworks and approaches. Barriers to the use of decision support tools in environmental policy agenda setting, design and implementation range from a lack of appreciation among decision makers about the potential benefits of using models and scenarios, to a lack of willingness on the part of some modellers to properly engage in real-world decision-making and undertake relevant analyses. Of the case studies reviewed that successfully applied decision support tools, the dedication and continuity of facilitators and modellers in close collaboration with decision makers throughout decision making processes was a consistent feature. Primary impediments to the widespread use of models and scenarios in decision making include: a general lack of trust in modellers, models and scenarios; a lack of understanding and technical knowledge among decision makers to allow them to understand outputs and appreciate the positive role that models and scenarios can play; a general lack of decision support, modelling and scenario analysis skills relative to the number of policy design and implementation challenges; a lack of data to underpin the models and scenarios of most interest to policy makers and managers; a lack of willingness on the part of some modellers to engage fully in real-world decision problems and develop and communicate in a non-technical way the most relevant scenarios and models for the problem at hand; a lack of willingness of modellers to engage in participatory processes involving other knowledge traditions and translation of model outcomes to other knowledge traditions; a lack of transparency in approaches to modelling and scenario development; and complex political agendas that are not amenable to the transparency ideally associated with good modelling and scenario analysis.

There is often a mismatch between the spatial and temporal grain and extent of biodiversity and ecosystem services models and the policy design and implementation needs of decision makers. The cross-scale, cross-sectoral, and cross-ecosystem linkages necessary for decision makers and stakeholders to understand more fully the implications of decisions are often absent. While significant progress has been achieved in understanding impacts and feedbacks between environmental variables across spatial scales, the needs of policy and decision makers are rarely paramount in determining data needs, necessary model outputs, and the types of scenarios and models that are developed. Knowledge about the state of key biodiversity and ecosystem service variables and how socio-ecological systems function and respond to stressors and human interventions depends on collection of new data at multiple organizational levels and by monitoring the impacts of decisions. Decisions will be best supported if assessment and decision support needs drive data collection priorities and the choice of scenarios, models and model outputs.

There are very few agreed standards of best practice for some of the most important and widely used assessment and decision support tools such as strategic environmental assessment. As a consequence, many assessments default to the lowest common denominator, especially when it comes to assessing impacts on biodiversity and ecosystem services of large, complex development proposals. There is an opportunity for IPBES to raise the bar on such assessments by promoting standards of best practice in assessment and decision support that require state of the art scenario analysis and modelling approaches be coupled with integrative, participatory decision support protocols and frameworks.

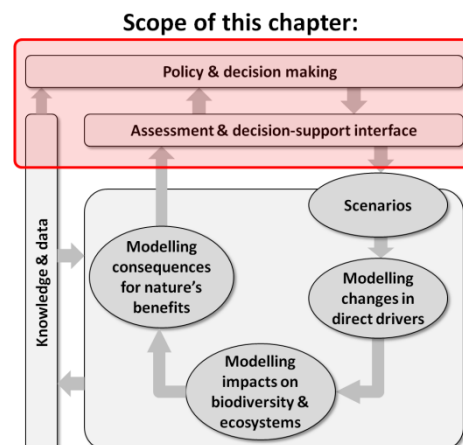

Uncertainty may contribute to poor decisions with negative social, economic and environmental outcomes. Decision-making processes are most likely to be effective if important uncertainties are characterised and addressed through the decision making process at the policy, planning and management levels. Environmental problems and the process of finding technical and management solutions to these are challenged by stochastic, linguistic, scientific and decision uncertainties with various levels of complexity and reducibility. Technical approaches to analysing the impacts of uncertainties on decision outcomes, including analysing the robustness of decision or planning options to various uncertainties can provide useful information to decision makers. Socially acceptable trade-offs under uncertainty can also be achieved through deliberation that allows feedback and learning among decision-makers and stakeholders.

Examples of integrating indigenous and local knowledge systems in models and scenarios and improved decision outcomes through participation of indigenous and local people are rare, though encouraging examples can be found. Ecological systems are complex and difficult to interpret with only one scientific discipline or knowledge tradition. The livelihoods of traditional knowledge holders are highly dependent on biodiversity and ecosystem services but they are frequently excluded from policy decisions, particularly at and above the national level. In order to make use of indigenous and local knowledge systems and encourage greater participation, numerous issues must be addressed, including complexities of multi-scale, multi-jurisdictional decision making, and the lack of capacity among many indigenous and local peoples to participate in decision making fora, and to understand, interpret, and contribute to modelling and scenario development.

Key recommendations

The Intergovernmental Platform on Biodiversity and Ecosystem Services (IPBES) global and regional assessments can be an important forum for fostering stronger links between ecosystem services and biodiversity experts, social scientists, modellers, decision support experts and decision makers. This can be achieved by allowing global and regional assessments to go beyond biophysical and socio-ecological assessments of state and trends to become fora in which policy options are expertly evaluated using a broad range of the relevant data, models, scenarios, and policy evaluation (decision support) methods and approaches. Increased collaboration between modellers and decision makers will lead to increased trust, better and more relevant models and scenarios, and a culture of decision support based on models and scenarios suited to complex policy and political agendas.

The typology and evaluations presented in this chapter provide a preliminary guide to which types of decision support frameworks, protocols and approaches are relevant to any particular policy design, implementation and review context. When considering which decision support frameworks, protocols and approaches are most relevant to a policy design, evaluation or implementation problem, IPBES Deliverables (especially 2b, 2c, 3b and 4c) could benefit from using the decision context typology and the decision support tools strengths and weaknesses evaluation presented in this chapter.

The task force on Capacity-Building (Deliverable 1a/b) could build on this assessment by seeking to foster and develop capacity in decision support expertise, including skills in biodiversity and ecosystem services modelling, scenario development and analysis, and improved understanding of, and expertise in the process of decision support. Decision support processes should utilize a variety of tools, protocols, and frameworks such as multi-criteria decision analysis, optimization, structured decision making, and other approaches summarised and reviewed in this chapter.

Outside of IPBES assessments, IPBES could promote forums and networks that link ecosystem services and biodiversity experts, social scientists, modellers, decision support experts and decision makers. The follow-up to this assessment (Deliverable 3c) and the policy and decision tools catalogue (Deliverable 4c) could use the decision context typology and the evaluation of decision support tool strengths and weaknesses in this chapter to help ensure that modelling and scenario analysis tools recommended to decision makers and their stakeholders are appropriate to their policy and decision context.

The IPBES task force on Knowledge, Information and Data, in combination with funding agencies and data providers could promote and facilitate data collection targeted towards decision-making needs and to support monitoring of the impacts of decisions on composition, structure and function of biodiversity and ecosystem services. IPBES global, regional and thematic assessments have the opportunity to identify data collection priorities that best address decision makers' needs by engaging decision makers and stakeholders in IPBES assessments and by utilizing the decision support frameworks, approaches, and tools described in this chapter to prioritize data gap filling.

IPBES deliverable on policy and decision tools (Deliverable 4c) and the scenarios and models expert group (Deliverable 3c) could promote standards of best practice in assessment and decision support that require state of the art scenario analysis and modelling approaches be coupled with integrative, participatory decision support protocols and frameworks when undertaking assessments of policies, plans and programmes that impact on biodiversity and ecosystem services. This can be achieved through the establishment of networks of decision-making practitioners, modellers, and experts in biodiversity and ecosystem services with the explicit aim of raising the bar on current approaches to assessment of policies, plans and programmes.

Thematic, regional and global assessments could consider identifying capacity needs for dealing with scientific uncertainties during decision making and work with the task force on Capacity-Building to foster and facilitate improved capacity for characterising, communicating and dealing with uncertainties that impact on decisions in a way that is consistent and based on agreed standards. IPBES assessments should seek to identify the uncertainties that impact most heavily on the capacity of decision makers to make decisions that are beneficial to biodiversity and ecosystem services. This will require discriminating between large uncertainties that are relatively benign, and uncertainties that are important because they impair decision making.

Thematic, regional and global assessments, in cooperation with the IPBES Task Force on Indigenous and Local Knowledge (Deliverable 1c) could use assessment and policy support approaches that integrate multiple spatial and temporal scales and recognize the importance of multiple and diverse knowledge systems. Formal participatory mechanisms need to be established to ensure local and indigenous participation and effective information exchange between scientists, and local and indigenous peoples.

2.1 Introduction

Decision support protocols have advantages over unaided decision-making because they provide and document the logic behind decisions. Apart from buffering against cognitive limitations and negative group dynamics, a documented and traceable decision support protocol will encourage decision makers to be clear about judgments and assumptions (Bedford and Cooke, 2001). Within decision-making processes, scenarios and models can play several important roles, including: (i) setting a policy agenda by highlighting previously poorly documented threats or opportunities; (ii) transparently representing assumptions about cause-effect pathways that link policies and actions to outcomes; (iii) reducing complexity by synthesising, analysing and representing multiple sources of information and evidence in a way that is most appropriate for the decision at hand; (iv) exploring and identifying unforeseen consequences of policies and actions; and (v) providing a means to synthesise and interpret policy, planning and management evaluation information, including monitoring data.

2.1.1 The policy cycle, knowledge needs and the role of assessment

An extensive literature documents policy theory and practice, and processes that influence policy design and implementation (e.g., Sabatier and Weible, 2014).

While there are many competing models describing policy processes, the simplicity and communication value of the four-phase policy cycle (Howlett et al., 2009) is of value here in providing a context for discussion about decision support tools relevant to decisions that impact on biodiversity and ecosystem services. Under this model, decision making occurs in four phases of the policy cycle; agenda setting (including problem identification), policy design, policy implementation, and policy review (Figure 2.1).

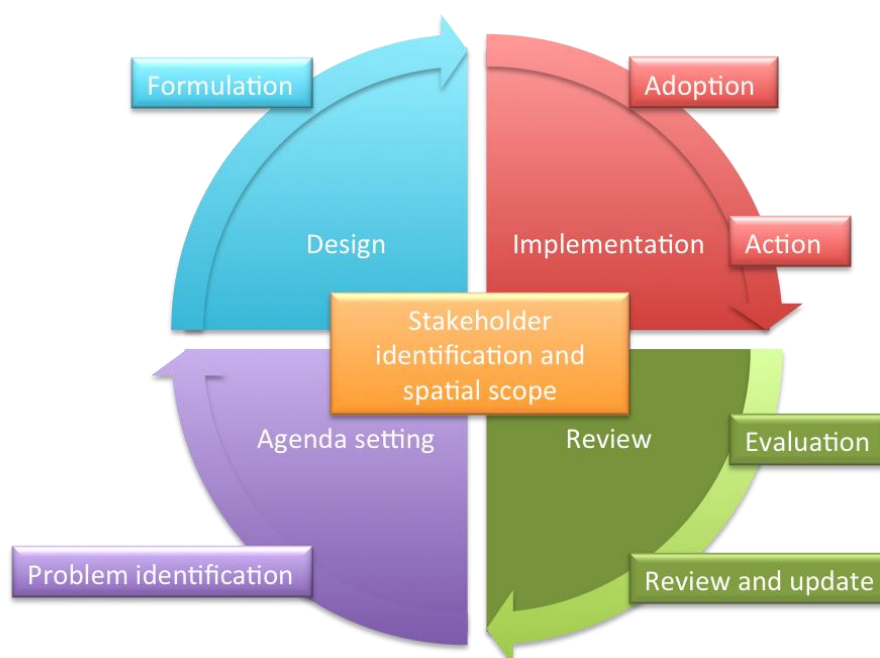

Figure 2.1: A theoretical framework for agenda setting, policy design, implementation and review (adapted from Howlett et al. (2009)). Although empirical evidence shows that real world decision-making usually does not follow an idealized sequence of discrete stages (Jann and Wegrich, 2007), the policy cycle helps organize discussion of the role of scenarios, models, and decision support approaches in decision-making that occurs in subsequent chapters. Numerous published frameworks exist that describe similar steps and approaches for structuring and implementing

policy and decision-making under uncertainty and complexity, including adaptive management and adaptive planning approaches (McFadden et al., 2011; Walters, 1986).

The four phases of the policy cycle have specific *knowledge needs* that can be partly met by biodiversity and ecosystem service models implemented under scenarios exploring implications of policy settings (Figure 1.3 in Chapter 1). For example, problem identification and problem scoping, including identification of the scope of assessments and stakeholders are all activities that take place under the broad banner of agenda setting. In many situations, modelling direct and indirect drivers of biodiversity and ecosystem services, embedded in exploratory scenarios (Chapter 3, 5), can provide important insights into the nature and magnitude of problems and opportunities that drive the development of specific policy options. This type of exploration can trigger new policy agendas. For example, Section 2.3.1 describes how a series of agenda-setting scenario analyses starting with the first Global Biodiversity Outlook (GBO) (sCBD, 2001) that contributed to development and agreement on Aichi biodiversity targets (MA, 2005; Alkemade et al., 2009; Leadley et al., 2014). Similarly, the policy design, implementation and review phases have knowledge needs that can be partly met through the use of scenarios, models and decision support methodologies. In implementation of policy, for example in land-use planning, scenarios, models and other formal decision support approaches are often used to help identify which activities will be allowed or encouraged in particular parts of the landscape in order to achieve landscape-level objectives for a range of criteria such as agricultural productivity, tourism service provision, and biodiversity conservation (FAO, 1993; SAPM, 2009). Policy implementation often involves management decision-making in the face of uncertain benefits and costs due to complex ecological or social system dynamics, and multiple criteria for measuring success. In such cases, decision support, including scenarios, models and structured approaches for analysing trade-offs can be extremely useful for ensuring that management is transparent, effective and efficient in meeting objectives for biodiversity, ecosystem service, and other criteria (Runge et al., 2011b).

During policy review, the outcomes of previously adopted policies can be compared to hypothetical counterfactual or alternative scenarios (Chapter 3, Table 3.1). Scenarios and models can be used to estimate biodiversity or ecosystem service outcomes under hypothetical policy settings alternative to the ones actually implemented. This sort of analysis is often called post-hoc or ex-post evaluation, and can provide valuable information about how to adjust policy settings with the aim of better achieving desired outcomes in the future, or simply as a form of transparent reporting on the performance of policies or programs. For example, Joppa and Pfaff, (2010) review a statistical technique called ‘matching’ to compare observed forest conservation status against counterfactual scenarios of forest loss in the absence of protection to estimate the effectiveness of forest conservation (Chapter 3).

This chapter sets the assessment and decision-making scene for the three other chapters of this deliverable that provide more detail on scenario development and modelling approaches relevant to particular decision contexts (Chapters 3, 4, and 5).

It links to Chapter 3 by identifying types of scenarios required to underpin decision-making, and to Chapters 4 and 5 by identifying the role of biodiversity and ecosystem service model outputs in agenda setting, policy design, implementation and review. This chapter also provides the foundation for Chapters 6 and 7 by highlighting scales and domains over which types of decisions occur, and capacity-building needs in the area of model-supported decision analysis. A view to the future of agenda setting and decision-making offers an entree to Chapter 8 by highlighting future developments which may see increased use of scenarios and models in decision-making.

2.1.2 Aims and Audience

This chapter aims to inform readers about the possibilities and opportunities for using scenarios, models and decision support protocols to support decisions in each phase of the policy cycle from agenda setting to policy design, implementation and review. A decision context typology is provided that defines the range of decision contexts in which scenarios and models may be useful. Decisions that impact on biodiversity and ecosystem services are defined according to *decision context attributes*. The aim is to try and reduce some of the complexity and confusion about the range of tools and decision protocols that may help to support decisions that impact on biodiversity and ecosystem services. The chapter seeks to improve understanding about the contexts in which decision support approaches may be useful, and demonstrate how they may be enhanced with the use of scenarios and models. Examples of where decision support approaches have been successfully integrated with scenarios and models to improve decisions are described.

This chapter principally addresses the following activities within the IPBES work programme; regional and global assessments (Deliverables 2b/2c), thematic assessments (Deliverable 3b), the scenarios and models expert group (Deliverable 3c) and the deliverable on policy and decision tools (Deliverable 4c) which will develop an online catalogue of policy support tools and methodologies relevant to IPBES related activities. Findings are also relevant to Deliverables 1a/1b on capacity-building, Deliverable 1c on indigenous and local knowledge, Deliverables 1d/4b on knowledge information and data, Deliverable 3d on valuation and Deliverable 4d on stakeholder mapping and engagement.

2.2 Decision-making context

2.2.1 Attributes that define decision context

Almost every policy, plan and action in every sector from health to manufacturing, at every spatial and organizational scale from the individual to the globe, impacts in some way on biodiversity and ecosystem services.

The number and types of decisions made appear to defy classification and are practically infinite (Fisher et al., 2009). The bulk of decisions or choices made on a daily basis that impact on biodiversity and ecosystem services are seldom described or conceived of as *environmental* decisions (a decision in which environmental considerations are explicit). Almost all are undertaken by people outside the environment sector with little or no consultation with environmental professionals. The following paragraphs describe attributes of the decision context (Table 2.1), with a focus on decisions that are readily identified as 'environmental decisions'.

The *governance system* under which decisions are made, and the degree to which power over a given decision is shared among *actors*, or across different *sectors*, contributes significantly to the types of decision support, scenarios and models that are useful. For example, so-called 'top-down', 'single-actor' decision problems may be amenable to application of economic optimization approaches, while more '*participatory*', 'multi-actor' decision processes may be better supported by deliberative approaches such as multi-criteria mapping (Stirling and Mayer, 1999; De Marchi and Ravetz, 2001). Other aspects of governance that determine how a decision will play out include the *history* and *legitimacy* of the governing institutions.

The *time horizon* for which a decision is expected to hold, and the *frequency* of decision making about a particular issue has a large influence on the sorts of scenario, modelling and decision support approaches that may apply. Sequential decision processes provide the opportunity to value the role of learning and to establish formal programs of 'continuous improvement', often invoking ideas embodied in adaptive management (Walters, 1986). However, with this opportunity comes complexity. Many reasons have been proposed for the conspicuous lack of working examples of adaptive management in broad scale, multi-objective decision problems including a reluctance to set measurable management objectives, a reluctance to invest in long-term monitoring of management outcomes, and a reluctance to formalise assumptions about cause-effect pathways as testable hypotheses or models (Walters, 2007; Wintle and Lindenmayer, 2008; Westgate et al., 2013).

Most environmental decisions are characterized by multiple competing views about what constitutes a good outcome (Keeney 2007). This arises because different stakeholders hold different *objectives*, which imply different criteria by which outcomes will be measured. Decisions that involve multiple objectives will tend to be more difficult to make than decisions for which there are few or only a single objective. One of the reasons why people hold different objectives for a particular decision problem is that they share different *values*. Decision problems characterised by multiple different values tend to be much trickier to resolve than when values are shared. A common challenge to decision making in many parts of the world arises because not all *stakeholders* share the same *knowledge system*. Very few analytical decision support approaches, including scenario development and modelling approaches are easily applied across multiple knowledge systems, though more deliberative, participatory processes tend to be favoured in such circumstances.

Differences in capacities and power determine the effectiveness of *stakeholder* representation and the acceptability of decision outcomes. Large and wealthy organizations, including companies and national governments may have greater resources and better access to information than other stakeholders, leading to a greater influence over the decision process. Assessing the impacts on livelihoods of policies, plans and management options may require culturally specific, local level understanding to properly evaluate costs and benefits to all stakeholders (Nordström et al., 2010; Rowland et al., 2014; Runge et al., 2011b). Cultural norms, values, practices, ideologies and customs shape people's understanding of their needs, rights, roles, possibilities and hence influence their actions, including engagement in policy design and implementation (Borrini-Feyerabend et al., 2004). All stakeholders use their beliefs as the basis for determining the range of options they will consider and the criteria by which they will measure outcomes. The importance of taking into account multiple belief systems during policy formulation is being increasingly recognized especially in areas where indigenous people have consolidated their property and representation rights (TEBTEBBA, 2010; UN, 2008; Runge et al., 2011b).

Uncertainty takes many forms (Regan et al., 2002) and impacts on environmental decisions in a variety of ways (Section 2.3.3, Ludwig et al., (2001)). Uncertainty can arise due to a lack of *information*, either in the form of traditional and *scientific knowledge*, *data* and/or *capacity*, or simply due to high levels of environmental and ecological *stochasticity*, and a variety of other sources (Section 2.3.3, Regan et al. (2002)). The degree and type of uncertainty inherent in a particular decision problem determines the sorts of analytical and decision support approaches that can be applied (Peterson et al., 2003; Regan et al., 2005) and partly motivates the need for scenarios and models. The role and implications of uncertainty in decision-making, scenarios and modelling are dealt with in Section 2.3.3.

High decision complexity provides a strong motivation to utilize decision support approaches because the complexity of many decisions exceeds the processing capacity of the human brain. Aside from the social, cultural and governance complexities already mentioned, *ecological* complexities such as the *heterogeneity* of ecosystems, the *diversity* of species involved, and the degree to which decisions have to address *cross-landscape* flows and connections make for more or less tractable decision contexts. Some 'local' decisions take place within a particular ecosystem or geographic domain that can be considered, for the purposes of the decision process, discrete and sufficiently buffered from the ecological processes playing out in other systems, so as to simplify the characterisation of biodiversity and ecosystem service values and dynamics. However, many land-use planning and policy processes play out over multiple ecosystems that are connected by complex flows of biotic and abiotic resources, and which are subject to multiple different types of ecological and social dynamics that may play out over multiple temporal scales. For example, some integrated catchment management strategies must consider simultaneously terrestrial, river, estuarine and near-shore ocean ecosystems, each with unique economic drivers and pressures such as agriculture, aquaculture, and fishing (e.g., Brodie et al., (2012).

Spatial and temporal scale, including the spatial and temporal grain and extent relevant to a particular problem drive the level of modelling, scenario and decision support sophistication required to support decisions. Biodiversity and ecosystem services have specific spatial and temporal distributions that overlap with human management units or jurisdictions in complex ways. Similarly, stakeholders have rights, obligations and interests at a variety of spatial scales, making *cross-scale dynamics* an important part of the decision context. Global responses to ecosystem problems are warranted when those problems potentially affect all people and ecosystems. Multilateral, regional and bilateral agreements require consensus by a group of nations but implementation often requires action within national boundaries. National policies exist independently of agreements with other nations, highlighting the problem of policies and plans that conflict across scales. The scale at which human and biotic processes operate influences the sorts of decision approaches, scenarios and models relevant to a particular decision. Spatial scale partly determines who will be represented in a decision problem and whose interests are considered.

Table 2.1

Attributes that define a decision context and how they vary.

	Decision context attributes	Easier to decide	More difficult to decide	Decision strategies for easier decisions	Decision strategies for more difficult decisions
Governance	<i>actors</i>	single/executive	multiple/negotiated	optimisation, benefit cost analysis	multi-criteria decision analysis (MCDA)
	<i>history</i>	history of governance	novel governance	learning	assessment
	<i>legitimacy</i>	accepted	contested	executive	conflict resolution
	<i>sectors</i>	single	multiple	executive	negotiation & bridging
	<i>participation</i>	consultation	decision	communication	participatory decision making
Decision	<i>decision time horizon</i>	short term (months)	longer term (decades)	optimisation	adaptive management
	<i>decision frequency</i>	one-off	repeated	assessment	monitoring & learning
	<i>objectives</i>	single	multiple	optimisation	MCDA, Analytic Hierarchy Process (AHP)
Stakeholders	<i>values</i>	homogenous	diverse	assumed	deliberation & negotiated
	<i>knowledge system</i>	homogenous	diverse	single process	bridge multiple processes
Information	<i>scientific knowledge</i>	high	low	optimisation, benefit cost	adaptive management
	<i>data availability</i>	high	low	optimisation, benefit cost	Delphi, robustness, deliberation
	<i>scientific capacity</i>	high	low	optimisation, benefit cost	deliberation, participation
Ecology	<i>heterogeneity</i>	single ecosystem	multiple ecosystems		
	<i>diversity</i>	single species	multi species		
	<i>flows across landscape</i>	weak connections	strong connections		
	<i>stochasticity</i>	low and predictable	high and unpredictable		
Scale	<i>cross-scale dynamics</i>	weak external influence	strong external influence		
	<i>temporal extent</i>	short-term	long-term		
	<i>temporal grain</i>	seconds	millennia		
	<i>spatial extent</i>	local	global		
	<i>spatial grain</i>	metres/seconds	kilometres/degrees		

2.3 Overview of agenda setting and decision support approaches

Many methods, approaches and tools exist to support activities in each phase of the policy cycle. A broad distinction is drawn between tools that support policy agenda setting (Section 2.3.1) and tools that support actual decisions in the policy design, implementation and review phases of the policy cycle (Section 2.3.2).

While the scenarios and models used in those two activities may be similar or identical, there are important differences in the way they are used that arise due to differences in the agenda setting versus policy design, implementation and review contexts. A non-exhaustive overview of the main families of agenda setting and decision support approaches is provided. Families of decision support approaches are described in rough order of complexity ranging from relatively generic tools, to more highly integrated frameworks (Section 2.3.2). Case studies of the application of several approaches are provided as boxed essays. A table documenting how each approach fits within the decision context typology is provided in Section 2.4. A database of case studies documenting applications of each decision support approach according to decision context variables will be provided to the IPBES scenarios and models expert group (Deliverable 3c) and the IPBES deliverable on policy and decision tools (Deliverable 4c).

2.3.1 Policy agenda setting

Agenda setting is one of four phases in the policy cycle (Figure 2.1) that motivates and sets the direction for policy design and implementation. Scenarios and models often play a role in agenda setting.

The first Global Biodiversity Outlook (GBO) (sCBD, 2001) presented information from national reports and a global evaluation of biodiversity trends (WCMC, 1992). These analyses were later augmented with exploratory scenario analysis in the second GBO – the *Crossroads of Life on Earth* study (sCBD and PBL, 2007). This study used GLOBIO as a modelling framework to assess the impact of environmental drivers on biodiversity and explore policy options in the form of intervention scenarios to reduce biodiversity loss and achieve the 2010 targets for biodiversity. The third GBO (Secretariat of the Convention on Biological Diversity 2010) also presents biodiversity scenarios and tipping points contained in a study incorporating the results of the Millennium Ecosystem Assessment (MA), the GBO 2 and the Global Environment Outlook (GEO) 4, as well as the Mini Climate Assessment Model (MiniCAM) (Leadley et al., 2010). The fourth GBO provides a mid-term assessment of progress towards the implementation of the *Strategic Plan for Biodiversity* and achievement of the Aichi biodiversity targets (Alkemade et al., 2009; Leadley et al., 2014). Each of these assessments have contributed significantly to the current policy agenda pertaining to biodiversity and ecosystem services at multiple spatial scales across multiple jurisdictions (Figure 2.2).

Global agendas play out at regional and national scales in many ways. Referring directly to the Convention on Biological Diversity (CBD), the National Performance Assessment and Sub-regional Strategic Environment Framework for the Greater Mekong Sub-region (GMS; ADB, 2010) was developed to guide the GMS Core Environment Program, through which the GMS governments create a vision and framework for long-term investment in environmental governance, institution building, environmental protection in the main development sectors, and conserving biodiversity. In this process, the GLOBIO3 model underpinned assessment of different policy options to reach biodiversity targets in the region (Figure 2.2).

At a regional level, the European Commission developed the European Union (EU) Biodiversity Strategy (European Commission, 2011). The EU Biodiversity Strategy was informed by an assessment of the 2010 biodiversity targets (EEA, 2009). These activities represent policy formulation and evaluation, following from the agenda set by CBD and MA (Figure 2.2). International fisheries policy in the same region has been influenced by models and scenarios at the same scale (Box 2.1). At a local scale, twenty-year Forest Agreements were signed between the Australian Government (responsible for implementing the Environment Protection and Biodiversity Conservation Act, (1999), and export licencing) and the New South Wales State Government (NSW - responsible for land management) that set out new forest conservation reserves and approved ecologically sustainable forest management systems in four regions across the state. Negotiation of agreements was based in part on C-Plan (Pressey et al., 2009), a participatory land use planning decision support tool that utilized species distribution models (Ferrier et al., 2002) and forest growth and yield models (Vanclay, 1994) to identify trade-offs between forestry production and species conservation objectives.

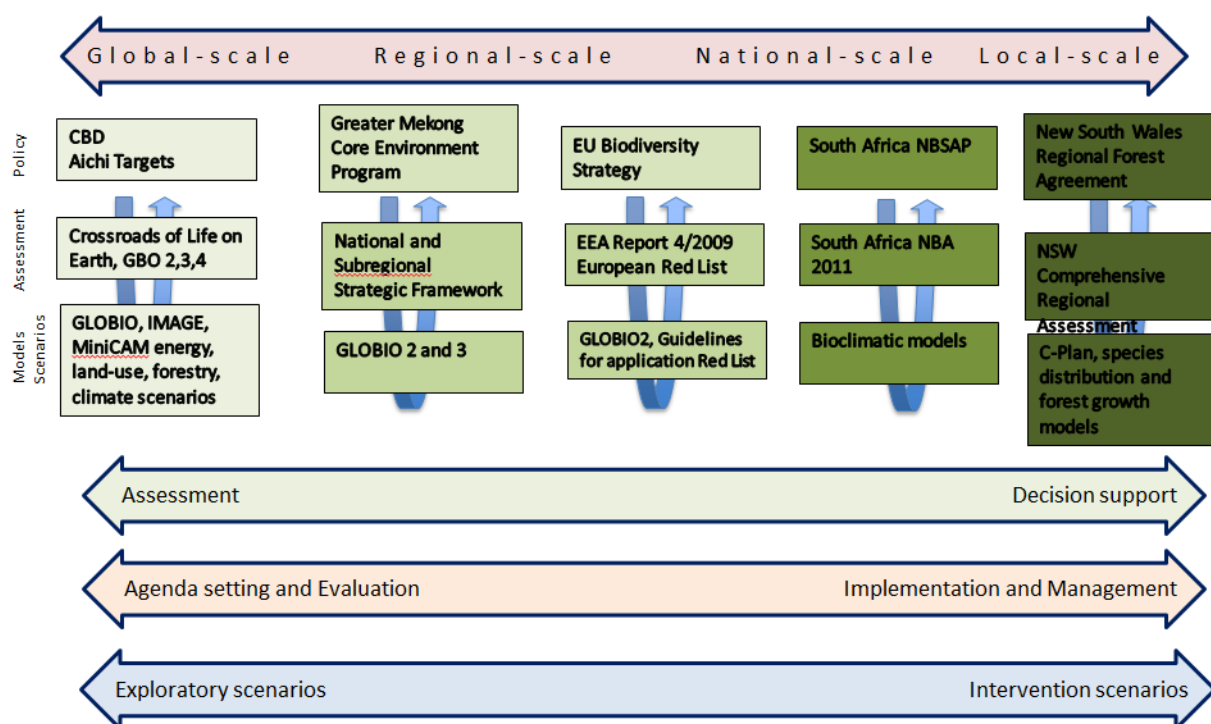

Figure 2.2: Commonly observed relationships between spatial scale, phase in the policy cycle and model or scenario type using Aichi biodiversity targets and subordinate activities as an example. At the global scale, CBD and Aichi biodiversity targets were partly informed by assessments, models and scenarios at that scale. Numerous subordinate processes at regional, national and local scales draw on the CBD and Aichi biodiversity targets to motivate policies, plans and actions. Lower level activities also draw on combinations of global (and finer) scale analyses, in concert with decision support protocols (Section 2.3.2) to design and implement policies. Both top-down and bottom-up modelling and scenario analysis approaches can support decision making at regional, national and local scales (Chapter 6). For example, the South Africa National Biodiversity Strategy and Action Plan (Deat, 2005) guides policy design and implementation at finer scales and was informed by the National Biodiversity Assessment (Driver et al., 2012) that used bioclimatic models to incorporate climate resilience into species and ecosystem planning. In New South Wales, Australia, correlative species distribution models and forest growth models were combined using a participatory decision-support software (C-Plan) to generate spatial land-use options for forestry and conservation objectives in four regions during the comprehensive regional assessment that preceded the regional forest agreements. It is acknowledged that while there is not a one-to-one correspondence between spatial scale and policy cycle phase or scenario type, this scheme does provide some insight into commonly observed hierarchies of policy, planning and action and some of the tools that are used at different levels in the hierarchy. For example, there could be a role for formal decision support protocols such as the Delphi or structured decision making approaches (Section 2.3.2) in setting Aichi biodiversity targets, but there is no documented evidence of this occurring in that process.

Box 2.1: Models and scenarios for policy agenda setting at a regional scale: European international fisheries policy.

The European marine policy frameworks have adopted ecosystem-based management, which requires indicators that describe pressures affecting the ecosystem, the state of the ecosystem, and the response of managers (Jennings, 2005); Figure Box 2.1). This adoption of ecosystem-based management is due to a shift in research effort from single species to ecosystem-based concerns which reflects a growing recognition that an ecosystem approach may help to underpin improved management (Jennings, 2004). Numerous published models describing the complexity of marine ecosystems (Baird et al., 1991; Baird and Milne, 1981; Baird and Ulanowicz, 1989; Piroddi et al., 2015) underpin indicators that drive the Marine Strategy Framework Directive (MSFD 2008/56/EC, European Union, 2008) that arose out of the Common Fisheries Policy (1982) (European Parliament, 2009). The Marine Strategy Framework Directive requires that European Union Member States achieve ‘Good Environmental Status’ under 11 descriptors of the marine environment by 2020. Of these 11, descriptor 4 (D4) addresses marine food webs: ‘All elements of the marine food webs, to the extent that they are known, occur at normal abundance and diversity and levels capable of ensuring the long-term abundance of the species and the retention of their full reproductive capacity’. The D4 indicator stipulated in the Commission Decision (European Commission, 2010; 2010/477/EU; Rogers et al., 2010), addresses three criteria related to food web structure and energy transfer. Descriptor 1 on biodiversity also relates to species distribution ranges, habitat extent, habitat condition and ecosystem structure. Many of these measures are dependent on habitat and ecosystem models as few are directly measurable at broad scales in the marine environment.

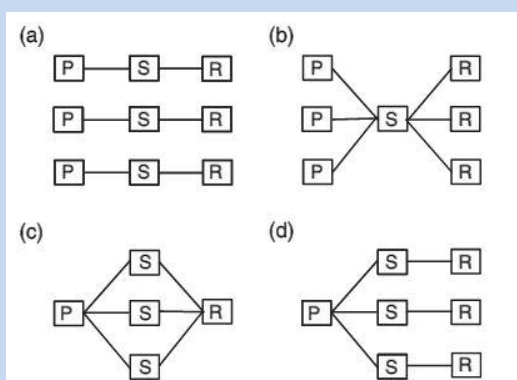

Figure Box 2.1: Possible relationships between pressure (P), state of the ecosystem (S), and response to a management action (R). Figures (b-d) illustrate that indicators of P,S, and R are rarely expected to map one-on-one as in (a). From Jennings (2005).

2.3.2 Families of decision support tools

A myriad of methods and approaches exist to support policy design, implementation and review phases of the policy cycle. Methods and approaches exist within a multi-dimensional ‘*decision context*’ (Figure 2.3), defined in part by *decision context attributes* (Table 2.1).

Tools and approaches range from technical tools within a very specific domain of application such as mathematical optimization approaches, through to broad frameworks such as ‘structured decision making’ (Gregory et al., 2012)

and adaptive management (Walters and Holling, 1990) that provide flexibility for dealing with most challenges confronting environmental policy makers and managers.

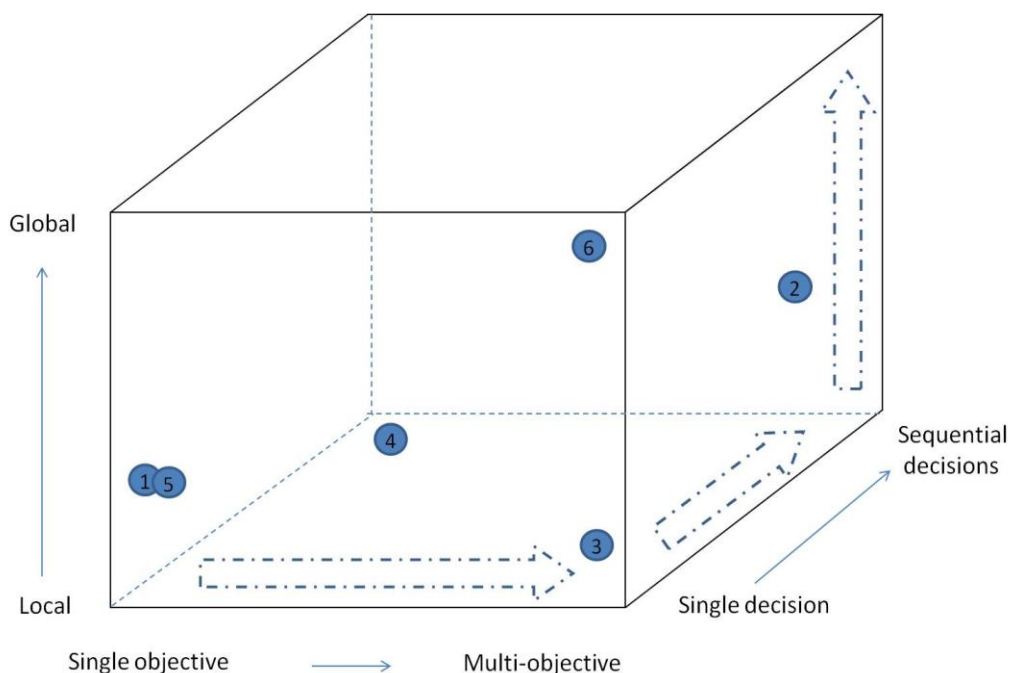

Figure 2.3: Three dimensions of decision context. Dashed arrows indicate increasing complexity from a single (once-off) decision made by a single group with a single objective at a local scale, to a sequential decision made by a group of decision makers with multiple (usually competing) objectives at regional/global scales. Numbered circles indicate individual applications of a given decision support method, undertaken in different parts of the decision space. For example, circle 1 represents a study (Joseph et al., 2008) in which a single organization (NZ DoC) used a single objective criteria (maximize increase in species persistence/\$) at the national level. Circle 5 identifies a conservation planning exercise, undertaken by the Malagasy governments, with the single objective of identifying the areas of Madagascar that would most efficiently increase the representativeness of the Madagascar reserve system (Kremen et al., 2008). There was no explicit consideration of sequentially increasing the reserve system or the multiple competing social or cultural objectives in the structured part of the reserve design process, though these considerations would likely have played out in the less structured political process. In contrast, study 2 reports on a decision process in which multiple cultural groups with multiple (incommensurable) objectives participated in a decision about the control of non-native fish species in the Glen Canyon dam in southern USA (Runge et al., 2011b). Study 2 was described as a ‘structured decision making’ exercise (Section 2.3.1.4; Gregory et al., 2012), supported by Multi Criteria Decision Analysis with swing-weighting to help identify dominated options. No value judgement is implied by this figure about where in decision space is the best place to be. The point to note is that different decision support approaches suit different parts of the space.

The following sections review a sample of decision support methods that occupy different parts of the decision context space (Figure 2.3). Case studies presented were chosen from 91 examples found in grey and peer-reviewed literature during a non-exhaustive search by the authors. Consequently, this is not an exhaustive inventory of methods, nor does it cover all parts of the decision context space. The aim is to provide an entree to a range of commonly used decision support methods, frameworks and approaches and to discuss the role of scenarios and models in each.

2.3.2.1 Multi-objective approaches to analyse trade-offs

Most decision making involves, either implicitly or explicitly, the analysis of risk. Risk is generally considered to be the product of likelihood and consequence (Burgman, 2005), which is essentially an estimate of expected utility (Savage, 1954). While consideration of adverse consequences alone will often suggest the desirability of risk avoidance or mitigation measures, conditioning estimates of consequence with assessment of likelihood may lead to the conclusion that risk avoidance or mitigation are not warranted (because likelihoods are sufficiently low). If estimates of likelihood and consequence are accurate, then decisions based on risk should lead to more efficient allocation of resources than considering only consequences (Arrow and Lind, 1970). Risk assessment approaches are used widely in environmental decision making (Burgman, 2005). Risk analysis forms the basis of environmental impact assessments (Section 2.3.2.3) and many of the integrative decision support approaches reviewed in this chapter. Risk analysis is needed anytime there is uncertainty that cannot be reduced, that is, when decisions have to be made in the face of risk.

The real world challenges of decision-making are seldom simple with high decision complexity being the norm in most decision contexts (Table 2.1). Consequences are seldom restricted to impacts that can naturally or readily be described by a single criterion (e.g., monetary). Multiple values imply multiple objectives each requiring estimates of consequence.

Uncertainty about consequences and likelihoods brings into play complex risk preferences that must be considered. Most decisions involve alternatives and cause-and-effect predictions of expected consequence, providing a natural role for scenarios (to characterise alternatives) and models (to predict consequences). When predictions are made over multiple objectives, an additional element is required to resolve the decision problem: articulation of preferences or trade-offs reflecting the relative importance of the different objectives (Howard, 2012). Most environmental policy, planning and management decisions involve trade-offs (Keeney, 2007).

Single attribute risk management tools do not directly treat trade-offs among competing objectives. A subset of these tools may be helpful in prompting exploration of cause-and-effect relationships using models during the process of estimating expected consequences for individual options or objectives, but on their own, they will generally be inadequate for making most real-world decisions that tend to involve trade-offs.

Consequence tables are the first of the multi-objective decision support tools described here to deal explicitly with trade-offs. There are three core elements to any multi-objective decision problem; alternatives, expected consequences and trade-offs. These elements are compactly reported in a consequence table. An example is shown below (Table 2.2), where alternatives comprise six hypothetical candidate options for reducing impacts on a near-shore reef system resulting from nutrient outflow from an agricultural catchment. The table can be populated with qualitative or quantitative estimates of expected consequence. Experts and non-expert stakeholders alike are notoriously deficient in their capacity to make internally consistent probabilistic judgments (Hastie & Dawes 2010). Modelling tools that assist in the coherent treatment of probabilities include fault tree analysis, event tree analysis, Markov analysis, Monte Carlo simulation, and Bayes nets. For example, Jellinek et al. (2014) developed a Bayes net to predict the relative improvement in vegetation condition resulting from a range of woodland management intervention scenarios such as reducing stock grazing and undertaking vegetation restoration.

Table 2.2

The example below uses coarse verbal (negative) impact descriptors typically seen in a qualitative risk matrix approach. Trade-offs involve consideration of the performance of each alternative against each objective. The top row represents six hypothetical candidate management options, and the first column gives each objective (criteria) against which expected consequences are assessed.

Example objectives	do nothing	A1	A2	A3	A4	A5	A6
Biodiversity - fish	High	High	High	Medium	Medium	Low	Low
Biodiversity - coral	Extreme	High	High	Medium	Medium	Low	Low
Economic cost	Low	Low	Medium	Medium	Medium	High	Extreme
Costs to implement	Low	Medium	Low	Low	High	Extreme	High
Recreational fishing	High	Medium	Medium	Medium	Medium	Medium	Low
Tourism	High	High	High	Medium	Medium	Low	Low

The preparation of a consequence table itself offers substantial insulation against the pitfalls of unaided decision-making. But unless the decision problem can be meaningfully simplified to two or three objectives and two or three alternatives, the cognitive and emotional demands on decision-makers and stakeholders can lead to poor outcomes such as environmental impacts that could have been avoided at little cost to development. In many instances, a consequence table can be simplified through identification of the *strictly* non-dominated set of alternatives (options for which no single alternative is better according to all criteria) and redundant objectives. An alternative is *strictly* dominated if, in comparison with any other single alternative, it performs worse on at least one objective and no better on any other objective. Driscoll et al. (2015) identify non-dominated sets of management strategies in a trade-off between asset protection, the provision of three ecosystem services (water provision, carbon sequestration and atmospheric pollutants) and the conservation of four species, in the context of wildfire management. Identifying a set of non-dominated options that represent a range of trade-offs between two or more criteria is also known as **Pareto analysis** (Chankong and Haimes, 1983). The set of options identified as the non-dominated set for a range of trade-offs between two criteria comprise the **Pareto frontier** (Chankong and Haimes, 1983, Driscoll et al., 2015).

If all expected consequences can be assigned a monetary value then **cost-benefit analysis** (also known as **benefit-cost analysis**) may be applicable. Selection of the option with the highest benefit-cost ratio has a strong basis in public policy and welfare economics. However, the monetisation of non-market values is difficult and some implementations of cost-benefit analysis avoid monetisation by seeking an alternative common currency.

Many applications of cost-benefit analysis rely on revealed preferences data (what people are prepared to pay). Where revealed preferences are deemed inadequate or absent, techniques for stated preference are available (Bennett and Blamey, 2001), but the time and resources required to apply these methods are substantial. In many cases, stakeholders are unlikely to feel comfortable with monetisation of all objectives, especially those dealing with social and environmental outcomes (Jax et al., 2013). Cost effectiveness analysis is a variant of cost-benefit analysis that accommodates non-monetary comparison of options. For example, Joseph et al. (2008) Joseph et al., 2008 utilized cost effectiveness analysis to prioritize threatened species conservation projects in New Zealand on the basis of extinction risk reduction achieved per dollar, weighted by phylogenetic uniqueness.

Maguire (2004) cites two interacting flaws commonly encountered in risk-based decision support: (a) incoherent treatment of the essential connections between social values and the scientific knowledge necessary to predict the likely impacts of management actions, and (b) relying on expert judgment about risk framed in qualitative and value-laden terms, inadvertently mixing the expert's judgment about what is likely to happen with personal or political preferences.

Multi Criteria Decision Analysis: Keeney and Raiffa (1976) is a way of analysing trade-offs between decision options according to multiple objectives (criteria). The family of techniques under the banner of Multi Criteria Decision Analysis seek to avoid the flaws in risk-based decision support identified by Maguire (2004) by explicitly separating the tasks of causal judgment (what might happen and why) and articulating value judgments or trade-offs (how one values particular outcomes: Ananda and Herath, 2009).

See example in Box 2.2. **Multi-Attribute Value Theory** is a foundational idea in Multi Criteria Decision Analysis. Applications of the Multi-Attribute Value Theory seek to describe a decision-maker's value function over two or more objectives and associated criteria:

$$v(x_1, \dots, x_n) = \sum_{i=1}^n w_i v_i(x_i),$$

where the w_i are the weights and the v_i are value functions for any single attribute. Weighting of the individual value functions can be done formally by the method of indifference, akin to the underpinnings of stated preference techniques used in evaluation of non-market impacts in benefit-cost analysis Bennett and Blamey (2001). There are many shortcut methods for eliciting weights Hajkowicz et al., 2000. Of these, the swing weight method has been shown to be one of the more effective, both in terms of its efficiency and its insulation against abuse (Fischer, 1995). Whatever method is used in their elicitation, the interpretation of the weights is critical. Methods that do not explicitly deal with indifference are prey to abuse. Users are inclined to specify weights that reflect the relative importance of the attributes, irrespective of the units or the range of consequences relevant to the decision context. But the weights have units because the underlying attribute scales have units. Changing the units or range of an attribute *must* lead to a change in the weights. For the *additive* value model to be valid the attributes need to be *mutually preferentially independent*. In practice, the assumption of preferential independence is reasonable if the set of objectives is complete, non-redundant, concise, specific, and understandable Keeney, 2007). Where objectives satisfy these properties there is a strong case for use of simple weighted summation. While the analyst needs to be careful to ensure preferential independence, the mechanics of the Multi-Attribute Value Theory are straightforward. Arithmetic operations are simple and easy to implement in a spreadsheet. Because the Multi-Attribute Value Theory is based on point estimates of consequence, it is strictly speaking, only applicable where there is no uncertainty in the estimation of consequences or where decision-makers and stakeholders can be assumed to be risk-neutral, such that value judgments are restricted to consideration of mean expectations rather than the full set of possible consequences encompassed by worst-case and best-case scenarios. Comprehensive descriptions of the Multi-Attribute Value Theory are provided by Bedford and Cooke (2001) and Keeney (2007).

Analytic Hierarchy Process is a Multi Criteria Decision Analysis application commonly encountered in the natural resource management literature Mendoza and Martins (2006). It is essentially a variant of the Multi-Attribute Value Theory designed to minimise the elicitation burden on experts and decision-makers. Most applications employ the same additive value model described above for the Multi-Attribute Value Theory. Using a nine point preference scale and matrix computations to translate ordinal judgments into cardinal judgments, (a) marginal value functions and (b) weights, are derived through pairwise comparisons of alternatives and objectives, respectively Saaty (1980). A variety of software packages are available, although for simple problems the calculations can be done in a spreadsheet.

The Analytic Hierarchy Process's strength in minimising elicitation burden is also its weakness. It is possible to obtain marginal value functions without any explicit estimation of consequences. For decision problems involving self-evident cause-and effect relationships this may be acceptable. This may fall down when consequences of alternative options involve difficult probabilistic judgments that are likely to be logically challenging Hastie and Dawes (2010).

The Analytic Hierarchy Process has also been criticised on theoretical grounds because it allows rank reversal upon introduction of a new alternative (Belton and Gear, 1983). The modified Analytic Hierarchy Process is free of this

problem. It uses standard Multi-Attribute Value Theory techniques to obtain marginal value functions, and limits the use of pairwise comparisons to the derivation of weights. (Moffett and Sarkar, 2006) advocate use of the modified Analytic Hierarchy Process because of the relative ease of obtaining weights. But like direct weighting, weights obtained through pairwise comparisons via the modified Analytic Hierarchy Process result in poor capture of stakeholder preferences. In general respondents tend to assign weights according to the perceived importance of objectives, irrespective of the consequences associated with the specific alternatives being considered, which is considered inadequate under conventional decision theory (Steele et al., 2009).

Outranking techniques stem from the French school of Multi-criteria decision analysis, which places less emphasis on normative understanding (assuming an ideal decision maker who is rational, fully informed, and able to compute accurately) of how decisions *should* be made based on axioms of rationality (von Neumann and Morgenstern, 1944) and greater emphasis on behavioural models of decision-making (Roy, 1973). Outranking techniques typically involve sequential elimination of alternatives (Chankong and Haimmes, 2008). Weights are assigned to each objective according to their perceived importance, without consideration of the range of consequences associated with alternatives. For each pair of alternatives a concordance index and a discordance index are constructed. The concordance index coarsely characterises the strength of the argument that one alternative is better than another based on the weighted sum of objectives for which it dominates the other. The discordance index reports the strength of the argument against eliminating the (weakly) dominated alternative. Decision-makers work through a consequence table iteratively, adjusting critical thresholds for concordance and discordance until a satisfactory choice is made.

There are numerous techniques and software packages that fall under the banner of outranking (e.g., ELECTRE, PROMETHEE, GAIA; see Figueira et al. (2005) for details). The techniques vary according to how expected consequences are characterised. If a consequence table is populated using qualitative ordinal descriptors of impact (e.g., Table 2.2), ELECTRE can informally assist stakeholders process trade-offs and difficult decisions involving more than a handful of objectives and alternatives. While other outranking techniques can be used where consequence estimates are quantitative or semi-quantitative, there is little argument for doing so, because in these circumstances the Multi-Attribute Value Theory offers a much firmer normative basis for decision-making.

The formal description of *Multi-attribute utility theory* developed by von Neumann and Morgenstern, 1944 remains a high point in the theory of multi-criteria decision-analysis. It is also a wholly impractical approach to typical multi-objective, multi-stakeholder problems. Many of the developments and refinements of Multi-criteria decision analysis since the 1950s are essentially pragmatic short cuts for the Multi-attribute utility theory. The Multi-attribute utility theory can be used when a consequence table is populated by statistical distributions describing probabilistic uncertainty in the performance of each alternative against each objective. In this way, the Multi-attribute utility theory provides a link between the Multi-Attribute Value Theory and risk analysis, allowing both the multiple-objective and the risk (utility) tools to be brought to bear on a problem. Given that many real problems contain these features, this can be considered a good thing. However, the circumstances in which this can be achieved are rare indeed, especially in natural resource management. Aside from difficulties in obtaining detailed probabilistic causal judgments, there are distinctly onerous demands on decision-makers and stakeholders in the elicitation of trade-offs under the Multi-attribute utility theory. Populating a consequence table with probabilistic outcomes clearly defines a strong role for scenarios and models. In practice, only the most committed and indefatigable participants in group decision-making settings are capable of formally addressing trade-offs using the Multi-attribute utility theory, highlighting the importance of technical modelling and scenario analysis support for the successful implementation of such approaches.

Box 2.2: Multi-criteria decision analysis case study – the use of a web-based Multi-criteria decision analysis system in participatory environmental decision making in Finland

Mustajoki et al. (2004) describe the use of Multi-criteria decision analysis in planning for multiple uses of the Paijanne Lake, Finland's second largest lake. The lake has been regulated since 1964, with the original objectives being to increase hydropower production and to decrease agricultural flood damages. The lake has extensive recreational housing developments along the shores and there are tens of thousands of recreational users and fishermen on the lake. There has been growing public interest to reconsider the regulation policy to better take into account the increased recreational use and current high environmental awareness. Problems currently recognized on the lake include the low water levels during spring, changes in the littoral zone vegetation and negative impacts of the regulation on the reproduction of fish stocks. An extensive multi-disciplinary research project was carried out in 1995–1999 to re-evaluate the regulation policy of the lake. The aims of the project were to assess the ecological, economic and social impacts of the regulation. Stakeholder opinions were sought about the current regulation and its development, comparison of new regulation policy options, and recommendations to diminish the harmful impacts of the regulation (as, for example in Figure Box 2.2). An open and participatory planning process was considered necessary to gain public support for the project and to find consensus on a new regulation strategy. A steering group consisting of 18 representatives of different stakeholders was set by the Ministry of Agriculture and Forestry, the permit holder of the regulation license. Additionally, four working groups were established to improve the communication between the water resource authorities, local stakeholders, experts on regulation, and researchers. To inform the public, a local press conference was arranged after almost every steering group meeting. In a survey of

participants, 80% agreed that ‘the recommendations for the regulation were able to combine the different and conflicting interests of both the people living on the Lake and the downstream water system’.

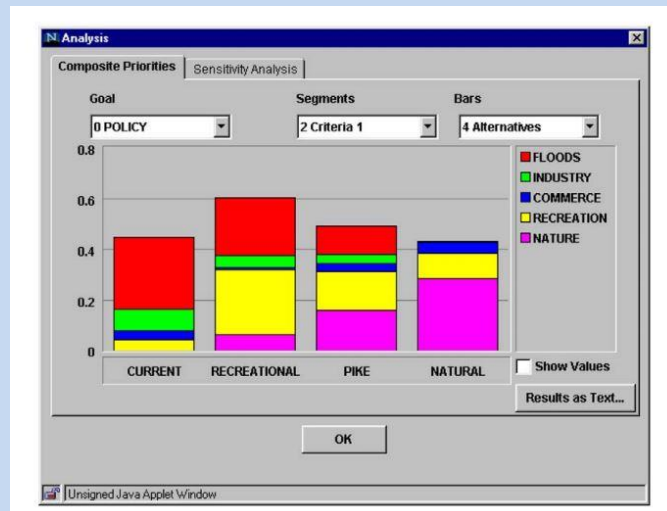

Figure Box 2.2: An example of the overall values of alternative management scenarios as determined by stakeholders from various sectors. From Mustajoki et al. (2004).

2.3.2.2. Optimization approaches

There are potentially thousands of alternative options in most real-world planning and management decision problems. Various mathematical programming techniques from the field of Operations Research are available to help identify better (or best) candidates from a large set Chankong and Haimes, 2008. Optimization approaches can be viewed as providing analytical machinery to assist in the generation and analysis of ‘target-seeking’ or ‘back-casting’ scenarios (Chapter 3).

Optimization problems are framed with a decision set, an objective and constraints. Depending on the characteristics of the problem and the relationship between the actions and the expected consequences (e.g., linear, convex, smooth or non-smooth, dynamic or not, deterministic or under uncertainty), there are various classes of resolution method Chankong and Haimes, 2008. A small sample is reviewed here. Two such classes of resolution method include **Linear Programming** and **Stochastic Dynamic Programming** that employ algorithms designed to optimise an objective function under specified constraints Chankong and Haimes, 2008. In Linear Programming, a linear relationship (or near-linear) relationship between actions and expected consequences is required. This may be inappropriate in many ecosystems, where outcomes for objectives are dynamic and non-linear in relation to actions or sets of actions. Both Linear Programming and Stochastic Dynamic Programming are single-objective optimization approaches. Multi-objective problems can be partly accommodated with the use of extra constraints. With detailed understanding of cause-and-effect, Stochastic Dynamic Programming can accommodate non-linear, dynamic outcomes associated with stochastic risk (e.g., risks associated with wildfires) superimposed on the deterministic influence of management actions (e.g., fuel reduction burning in high fire risk places). Stochastic Dynamic Programming recognises that what might be considered a desirable action depends on the state of the system (Minas et al., 2012; Richards et al., 1999). For example, low fire risk and a strong social preference for minimal management that impacts on natural values may imply lower preference for risk reduction (planned) burning compared to circumstances where fire risks are high (lots of woody debris) and public concern about active management of forests is low. The capacity to capture greater realism in Stochastic Dynamic Programming is attractive, but computational overheads, the curse of dimensionality (inability to deal with very large numbers of possible states), and the requirement for sophisticated causal understanding mean that most applications are substantially simplified. **Goal programming** requires specification of a performance aspiration for each objective. The underlying algorithm searches among the candidates for the alternative having the minimum multi-dimensional distance to the goal set (Chankong and Haimes, 2008). A single decision-maker can use the method profitably. In a multi-stakeholder setting, Goal programming is open to abuse because stakeholders will tend to manipulate outcomes through articulation of insincere positions on what might be considered an appropriate goal for each objective.

Integer Linear Programming is able to address many nonlinear optimization problems by using linearization techniques and commercially available Integer Linear Programming solvers. Substantial progress has been made in the field of nonlinear mathematical programming with continuous or integer variables. Numerous optimization problems can be formulated within this framework and articles published in the conservation and biodiversity protection are based on these techniques (Billionnet, 2013).

Heuristics are often used for decision optimization problems that cannot, for a variety of reasons including high complexity or size, yield exact optimal solutions. Examples of commonly used heuristics include **Simulated**

Annealing, *Tabu Search*, and *Genetic Algorithms* (Dréo et al., 2006). Graph theory is also a powerful tool for modelling and solving optimization problems (Krichen and Chaouachi, 2014). Some commonly used spatial conservation prioritization approaches such as *Zonation* (Moilanen et al., 2005) and *Marxan* (Possingham et al., 2000) utilise heuristics.

2.3.2.3 Integrative approaches

This last family includes a large number of frameworks, approaches and methods, few of which can be described here. For every approach described multiple variants exist, often with similar structure and underpinnings, but with different names arising from application in different sectors (e.g., forestry, fisheries, transport) or regions. Here a brief overview of integrative approaches is provided.

Scenario Planning – Scenarios, as defined in Chapters 1 and 3, are now routinely incorporated in a wide range of decision support approaches, including integrative approaches such as *management strategy evaluation* or *structured decision making* (Little et al., 2011; 2.3.1.4). Scenario analysis provides a framework in which to explore, characterise and organise uncertainties across spatial scales (Biggs et al., 2007).

Early developments in scenario analysis led to a particular decision support approach known as *Scenario Planning* (Schoemaker, 1995). Börjeson (2006) refer to *scenario planning* as a tool for exploring possible, probable and/or preferable futures. Identifying strategies or options that are robust to a range of possible scenarios is also key in scenario planning (Peterson et al., 2003).

While scenarios are used in a wide range of agenda-setting activities and as part of integrated decision support approaches, the relatively long history of scenario planning (Chermack, 2011, Schwartz, 1995) demands a specific mention here. Unlike forecasting with the aim of accurately predicting future events, the focus of scenario planning is to explore possible futures that may arise under different conditions, and what those different futures might mean for current decisions (Schoemaker, 1995). Assumptions about future events or trends are questioned, and uncertainties are made explicit (Bohensky et al., 2006). Scenario planning typically takes place in a workshop setting. Participants explore current trends, drivers of change, key uncertainties, and how these factors might interact to influence the future (Schoemaker, 1993). To do so, they draw on both qualitative and quantitative information, including datasets (WCS Futures Group and BIO-ERA, 2007), spatially explicit data (Santelmann et al., 2004), and expert/ stakeholder judgement (Schoemaker, 1993). Based on this information, a set of plausible future scenarios is developed. Participants then consider a range of policy or response options, and assess how robust those options are to the different scenarios developed (Box 2.3).

Shell Oil's navigation of the oil crisis of 1973 is an iconic example of the use of scenario planning, in which the company adjusted its business practices to buffer itself against the unlikely scenario of oil supply constraints (Peterson et al., 2003). In recent years, there have been many applications of scenario planning on a landscape scale with a focus on biodiversity and ecosystem services (Steinitz et al., 2003; Baker et al., 2004; Berger and Bolte, 2004; Hulse et al., 2004; Shearer, 2005; Walz et al., 2007; Patel et al., 2007; Santelmann et al., 2004). Others have combined scenario planning approaches with modelling approaches that incorporate human behaviour to better understand or characterise the effectiveness of policies or planning options (Happe et al., 2006; Bolte et al., 2006; Carmichael et al., 2004; Ittersum et al., 2008; Wei et al., 2009). Some studies (Liu et al., 2007; Meyer and Grabaum, 2008) have found optimisation and scenario analysis to be valuable in combination for selecting land use and management alternatives under uncertainty.

Strategy or option evaluation under scenario planning is commonly somewhat subjective. More formal decision analysis methods can be used to support the evaluation of planning options under a range of scenarios (Goodwin and Wright, 2001), avoiding some of the pitfalls of subjective strategy evaluation. Schoemaker (1991) suggests that scenario planning should be used as a preliminary phase in the decision making process, enabling the decision makers' ideas to be clarified, before moving to formal decision analysis methods designed to support decision making under uncertainty (e.g., Multi-attribute utility theory, Section 2.3.2.1), though reservations about this approach have been raised (Goodwin and Wright, 2001).

Box 2.3: Case study – Scenario Planning in the Hudson River Estuary Watershed

In 2008, The Nature Conservancy worked with communities in the Hudson River Estuary Watershed, USA, with the aim of preparing for the impacts of climate change (TNC, 2009; see also Cook, Wintle, et al. (2014) for further analysis). In a series of workshops over the course of 18 months, more than 160 stakeholders were consulted, including railroad executives, utility companies, the insurance industry, emergency and health groups, planners and conservation leaders. They identified and discussed important drivers (e.g., land use trends, the political climate) and key uncertainties around those drivers (e.g., will there be strong 'top-down' political support for climate change adaptation?). By manipulating these uncertainties and trends, they created four plausible scenarios. Scenarios were described using suggestive titles (e.g., Stagflation Rules) and narrative details, e.g., 'the early years of the scenario witness low to negative economic growth, falling real estate values and little new development in the region...'. Different elements of each scenario were specified, for example, the projections for the price of gas under the

Procrastination Blues scenario were ‘decline from \$3.80 to \$2.05 from 2008-2011, then rise rapidly back to \$5.00/gal by 2016...’. The feasibility of different policies or response options (e.g., changing the requirements for new storm water permits) could then be evaluated, in terms of both the likelihood that they would be adopted in each scenario and how they would perform in each scenario. The ‘top performing’ options were those that scored relatively highly across the four scenarios (Table Box 2.3). This project provides a good example of the potential of scenario planning for evaluating intervention options. Focussing on the Hudson River Estuary Watershed provided clear geographic scope, the drivers explored were well defined and easily monitored (e.g., the price of gas), meaning that trends within different scenarios could be explicitly and realistically quantified. The response options evaluated were specific enough to be implemented on the ground, for example, developing emergency actions plans with community involvement.

Table Box 2.3

The top five performing response options for the four scenarios. The response options were evaluated by participants using a numerical scale that yielded a combined score for total likelihood of adoption and total performance. From TNC, 2009.

Top Five Performing Response Options By Scenario					
Response Option	Procrastination Blues	Stagflation Rules	Nature Be Dammed!	Give Rivers Room!	Total
Hold regular, neighborhood meetings to “listen” to local adaptation needs, and mobilize local resources in response	1	4	1	4	10
Develop and update emergency actions plans with community involvement. Coordinate with State Emergency Management Office.	1	3	3	3	10
Require local community governments to work with the NYS Emergency Management Office (NYSEMO) to complete and update regional hazard and pre-disaster mitigation plans	1	3	2	3	9
Require all state agencies to conduct flood audits of critical infrastructure	0	3	3	3	9
Change requirements for all new storm water permits	-1	4	2	3	8

Both technical and deliberative approaches to dealing with uncertainty in decision making often draw on the concept of *adaptive management* (Walters and Holling, 1990). Adaptive management is a formal procedure for learning by doing, that is particularly amenable to sequential decision problems (Holling, 1978).

The sequential nature of the decision making is what provides the possibility for learning (from previous experience) and continuous improvement of future decisions resulting from a better understanding of (reduced uncertainty about) the system being managed. Adaptive management has seen strong application in fisheries (Hilborn, 1992; Walters, 2007), providing theory underpinning management strategy evaluation approaches (Smith, 1994). Terrestrial wildlife management and conservation have also seen successful application of adaptive management (Johnson et al., 1997; McDonald-Madden et al., 2010), and its potential role in invasive species management is also recognised (Shea et al., 2002). Decision makers and policy analysts commonly invoke adaptive management as a valuable heuristic supporting continuous improvement, though many applications explicitly include a formal plan for learning (e.g., via model refinement); a fundamental aspect of adaptive management (Holling, 1978).

Despite the appeal of the adaptive management concept, documented examples of it working in practice are surprisingly few (Westgate et al., 2013, but see Box 2.4 for an exception). Successful working examples appear to be characterised by decision contexts involving a single-jurisdiction, relatively few objectives to balance, continuous involvement of strong technical expertise, relatively low social and cultural complexity and conflict, and a strong institutional commitment to on-going management and funding to support it. Numerous reasons for the failure of adaptive management strategies have been proposed, including failure to support on-going monitoring and management costs.

Box 2.4: Dealing with uncertainty - Adaptive management of North American Mallard ducks.

Nichols and Williams, (2006) summarise an adaptive management program that has been working since 1995 to support the management (hunting regulations) of mid-continent Mallard ducks (*Anas platyrhynchos*) in North America. Management objectives are to maximize cumulative harvest over a long time period (including the devaluation of harvest when predicted population size falls below the North American Waterfowl Management Plan goal threshold of 8.8 million breeding mallards). Management actions include four regulatory packages (intervention

scenarios) specifying daily bag limits and season lengths for each of the four major North American flyways (Nichols et al., 2007). Four models of system response to harvest management are included in the model set. These models reflect two different hypotheses about the effect of hunting mortality on annual duck survival (compensatory mortality reflecting minimal effects of hunting and additive mortality reflecting maximal effects of hunting mortality), and two hypotheses about the strength of density-dependent relationships defining reproductive rates (weakly and strongly density-dependent). At the initiation of this management process in 1995, all four models (representing all possible combinations of these four hypotheses) were given equal credibility weights of 0.25, indicating no greater faith in the predictions of one model than in those of any other (Figure Box 2.4). A complex monitoring program is used to estimate breeding population size and number of wetlands in Prairie Canada (an important environmental covariate), rates of survival and harvest, and pre-season age ratio. In each spring, the new estimate of population size is compared against predictions made the previous spring corresponding to each of the four models. These comparisons are combined with the model weights from the previous year to update the weights. Learning therefore occurs when weights become large for some models, giving them more credibility and thus more influence in the decision process, and small for others. The decision about which set of harvest regulations to implement depends on system state, as defined by estimated numbers of ducks and ponds.

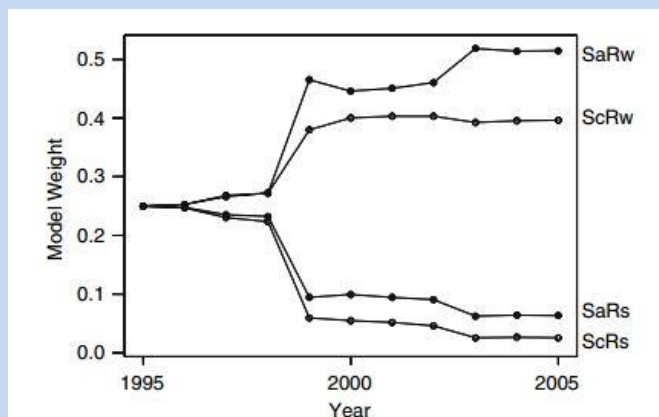

Figure Box 2.4: The evolution of belief for four models of Mallard duck responses to management. Adapted from Nichols et al., (2007) and U. S. Fish & Wildlife Service, (2007).

Structured Decision Making (Gregory et al., 2012) derives from multi-attribute utility theory (Raiffa, 1968; Section 2.3.2.1). However, structured decision making also draws heavily on more recent developments in *Decision Analysis* (Keeney, 1982; Hammond et al., 1998) and psychology (Kahneman & Tversky 2000). It is an organized approach to identifying and evaluating creative options and making choices in complex decision situations.

Gregory et al., (2012) define structured decision making as ‘the collaborative and facilitated application of multiple objective decision making and group deliberation methods’. Structured decision making is designed to deliver insight to decision makers about how well their objectives may be satisfied by potential alternative courses of action. It helps to find acceptable solutions across groups, and clarifies divergent values that may underpin irreducible trade-offs. It is a very general approach to decision support (Figure 2.4), which can conceivably be applied to any environmental decision problem at any scale and any level of social and institutional complexity. It has the capacity and flexibility to utilise scenarios and models of almost any form to inform judgements about the implications for biodiversity and ecosystem services of any intervention or future. However, it is the value of structured decision making in situations in which there are conflicting values and conflicting views about the consequences of various courses of action due to uncertainty that differentiate it from the simpler analytical (or ‘normative’) approaches (Gregory et al., 2012). The attributes of structured decision making that distinguish it from Multi Criteria Decision Analysis are the emphasis placed on the understanding and dealing with difficult group dynamics through a collaborative, participatory approach to clarifying objectives; exploring cause and effect relationships; and dealing with contentious trade-offs. To some extent, the application of structured decision making formalizes or prescribes an approach to dealing with the ‘human’ elements of decision-making, including judgement biases, group dynamics, and risk preferences. Tools such as Multi Criteria Decision Analysis may be used in an structured decision making process where they add value or clarity to the process, but the process itself is not centred on the use of any such tool (e.g., Box 2.5).

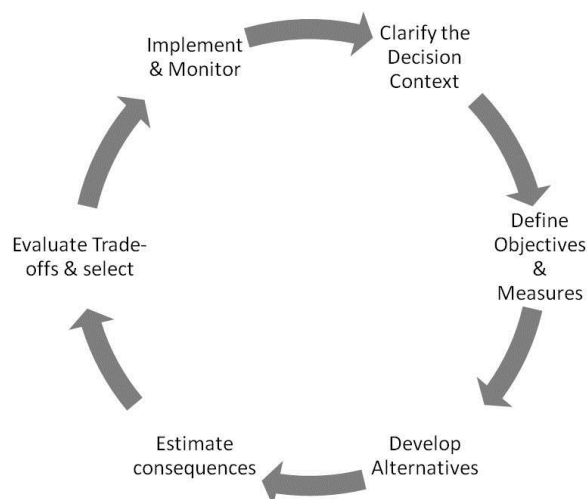

Figure 2.4: Six basic steps in Structured Decision Making (Adapted from Failing et al., 2007). Note similarities with the policy cycle (Figure 2.1), adaptive management (Walters, 1986) and management strategy evaluation frameworks (Figure 2.5).

There are six basic steps identified in Structured Decision Making (Figure 2.4; Gregory et al., 2012). Clarifying or scoping the decision context involves identifying what the decision is about, which decision(s) will be made, by whom, and when. The spatial and temporal scale over which the decision applies is a key component of clarifying the decision context. Defining objectives and performance measures is a big focus of the structured decision making approach, which defines what matters in the decision context and how these things will be measured. Objectives and performance measures drive the search for management and policy options and provide the basis on which they will be compared. The use of objective hierarchies is characteristic of most applications, possibly due to the strong focus on collaboration and encouraging participants to explore, and hopefully better understand each other's values. Developing decision alternatives is a creative, deliberative process that aims to tailor candidate actions (or actions sets) in a way that serves the defined objectives. Action sets can be thought of as intervention scenarios that can be played out in combination with exploratory scenarios about the future outside the control of decision makers. It is quite common that certain actions most suit the objectives of a particular stakeholder. Evaluating the performance of a particular stakeholder's preferred actions against the criteria of other stakeholders is a key part of understanding the consequences of each alternative. A basic tool used widely in structured decision making is the consequence table (Section 2.3.2.1) that sets out the expected outcome of each action for each performance measure relating to an objective. The process of estimating consequences of actions for objectives is a key place in which biodiversity and ecosystem service models can play a role in the approach. Models and scenarios can help in the exploration of expected outcomes arising from courses of action and the uncertainty about those expected outcomes. Evaluating trade-offs and selecting favoured options then proceeds by considering which options provide reasonable outcomes across all of the objectives considered. Proponents of structured decision making are generally eager to point out that the evaluation of trade-offs involves 'value-based judgements about which reasonable people may disagree' (Gregory et al., 2012). Finally, implementation and monitoring of outcomes enables some post-hoc evaluation of outcomes for the purposes of reporting and learning (McDonald-Madden et al., 2010); providing opportunity for the structured decision making process to be adaptive (Walters, 1986).

Two key strengths of structured decision making emerge from many of the reported applications. These include the clear separation of facts from values that is at the heart of the approach (Maguire 2004), and the way in which the approach helps to partition and therefore simplify the technical and social complexity that commonly hinders most real-world decision problems.

One of the developers of structured decision making theory and practice describes it as '... the formal use of common sense for decision problems that are too complex for informal use of common sense' (Keeney, 1982). This quote highlights the point that there is nothing mysterious or even particularly new about any aspect of structured decision making, other than the way in which it brings together may key concepts from decision theory toward a workable protocol for deliberations.

A weakness of the approach is that guidance on how to undertake any given step within the 'cycle' tends to be minimal and vague. The key text on structured decision making for environmental applications (Gregory et al., 2012) emphasizes that the use of the approach is something of an art. Knowing which specific tools to employ in any given decision context at each stage of the process requires significant experience. This means that the approach cannot simply be used 'off-the-shelf' by inexperienced analysts.

Box 2.5: Structured Decision Making for non-native fish management in the Glen Canyon Dam.

Runge et al., (2011) describe a structured decision-making project run by the U.S. Geological Survey concerning control of non-native fish below Glen Canyon Dam in the states of Utah and Arizona in the USA. They created a forum to allow agencies and Tribes to articulate their values, develop and evaluate a broad set of potential non-native fish control alternatives, and to define individual preferences on how to manage the trade-offs inherent in this managing the problem. Two face-to-face workshops were used to discuss objectives and represent the range of concerns of the relevant agencies and Tribes. A set of non-native fish control alternatives was developed. Between the two workshops, four assessment teams worked to evaluate the control alternatives against an array of objectives (e.g., Figure Box 2.5). At the second workshop, the results of the assessment teams were presented. Multi-criteria decision analysis was used to examine the trade-offs inherent in the problem, and allowed the participating agencies and Tribes to express their individual judgments about how those trade-offs should best be managed in selecting a preferred alternative. An effort was made to understand the consequences of the control options for each group's objectives. In general, the objectives reflected desired future conditions over 30 years. Multi-criteria decision analysis methods allowed the evaluation of alternatives against objectives, with the values of individual agencies and tribes deliberately preserved.

Trout removal strategies in particular parts of the catchment, with a variety of permutations in deference to cultural values, were identified as top-ranking portfolios for all agencies and Tribes, based on cultural measures and the probability of keeping the endangered humpback chub (*Gila cypha* - www.iucnredlist.org/details/full/9184/0) population above a desired threshold. Sport fishery and wilderness recreation objectives were better supported by the top-ranking portfolio. The preference for the preferred removal portfolios was robust to variation in the objective weights and to uncertainty about the population underlying dynamics, over the ranges of uncertainty examined. A 'value of information' analysis (Runge et al., 2011a) led to an adaptive strategy that includes three possible long-term management actions, and seeks to reduce uncertainty about the degree to which trout limit chub populations, and the effectiveness of particular removal strategies in reducing trout emigration to where the largest population of humpback chub exist. In the face of uncertainty about the effectiveness of the preferred removal strategy, a case might be made for including flow manipulations in an adaptive strategy.

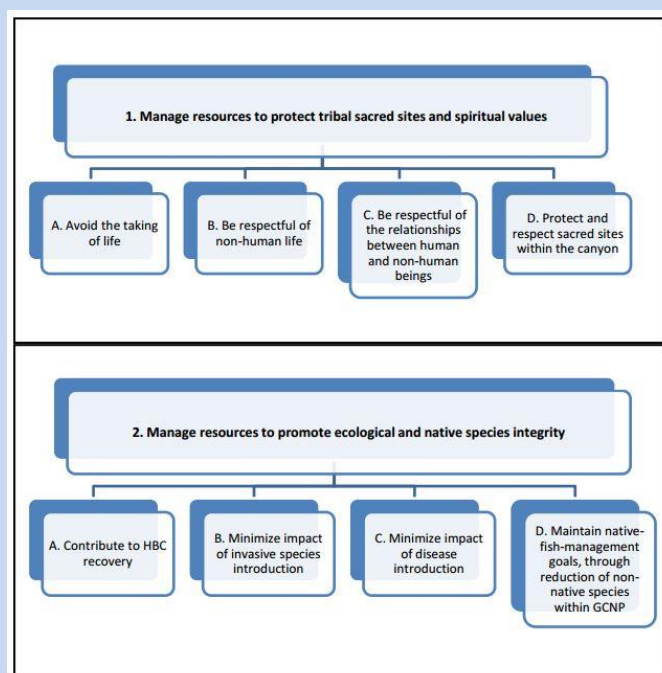

Figure Box 2.5: Example of hierarchies of two of the five fundamental objectives for non-native fish control below Glen Canyon Dam. Adapted from Runge et al., (2011).

Management strategy evaluation (sometimes termed *Management Procedure Approach*, *Harvest Strategy Evaluation* or *Operating Management Procedures*) uses simulation models within an adaptive framework (Walters, 1986) to evaluate management options. The objective of the approach is to assess the consequences of alternative management strategies in a virtual world, taking multiple and often competing objectives into account (Butterworth, 2007; Bunnefeld et al., 2011; Smith, 1994).

Thus, management strategy evaluation can be used to reveal the trade-offs in performance across a range of management objectives (Holland, 2010; Smith, 1994). Management strategy evaluation does not prescribe an optimal

strategy; instead, it provides the decision maker with the information about the implications of different options (intervention scenarios) upon which a rational decision can be based (Smith, 1994).

The conceptual framework and the subsystems modelled by management strategy evaluation are shown in Figure 2.5; the modelling steps are discussed based on Rademeyer et al., (2007). An ‘operating model’ (or preferably, a set of candidate models) is created to address all of the key biological processes, trade-offs and uncertainties to which an ideal management procedure would be robust (usually one model is chosen as a reference model). These operating models (most typically population dynamics models) are used to compute how the resource responds to alternative scenarios (different future levels of catch or effort). Then performance of each model is integrated over all the considered scenarios. Likelihood of the occurrence of each scenario is regarded as a relative weight given to the output statistics. The final management strategy (procedure) ideally is chosen based on clear, *a priori* defined objectives.

Management strategy evaluation is typically used in the marine context to identify fishery rebuilding strategies and ongoing harvest strategies for setting and adjusting the total allowable catch, but terrestrial conservation applications are likely (Winship et al., 2013; Edwards et al., 2014; Bunnefeld et al., 2011).

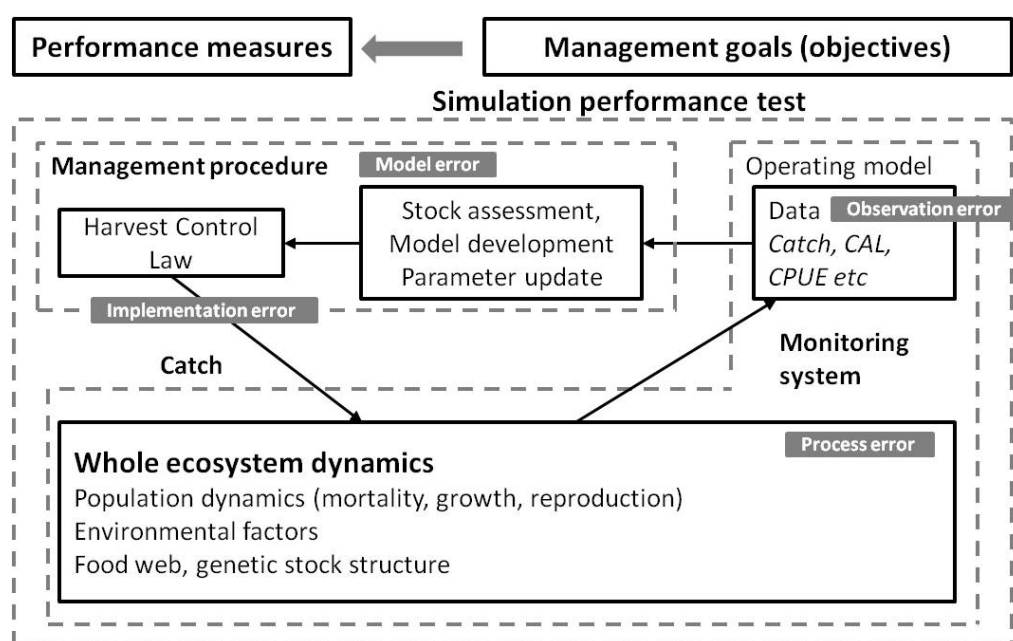

Figure 2.5: The management strategy evaluation framework (Adapted from Adam et al., (2013), p.5).

A core strength of management strategy evaluation is its transparency and explicit consideration of natural variation and uncertainty in stock assessments and implementation of management controls (Punt and Donovan, 2007; Holland, 2010). Multiple candidate models are generally considered within simulations to evaluate and test sensitivity to competing hypotheses (Rademeyer et al., 2007). Management strategy evaluation promotes consultation (Bunnefeld et al., 2011) whereby managers and other stakeholders can provide input into the candidate models and scenarios (Nuno et al., 2014), though participation is not a defining feature of management strategy evaluation. Recent applications have included indigenous interests in the management of socio-economic systems (Plaganyi et al., 2013). Technical demands due to complexity and reliance on computer simulation present challenges to wider adoption in fisheries management (de Moor et al., 2011).

Box 2.6: Management strategy evaluation case study – Joint management of fisheries in South Africa.

Plagányi et al., (2007) reports about the management of South African sardine and anchovy fisheries. The two species have to be managed jointly as anchovy harvest is necessarily accompanied by the bycatch of juvenile sardine; however the latter is more valuable when adult, resulting in a trade-off. In the first joint management plan in 1994, total allowable catches were calculated based on abundance estimates from recruitment hydroacoustic surveys and spawning biomass. The total allowable bycatch of sardine was based on the anchovy total allowable catches, but the latter was not affected by the total allowable catches or total allowable bycatch of sardine. However, the constraint posed by the sardine total allowable bycatch proved to be too strict, thus the management plan was updated in 1999 to allow a more flexible sardine total allowable bycatch to be set, depending on the relative recruitments estimations of the two species at any point in time. A trade-off curve was used in the selection of management goals to show explicitly the inverse relationship between the projected anchovy catch, with its associated juvenile sardine bycatch, and the directed (adult) sardine catch (Figure Box 2.6). Individual rights-holders in the fishery select their own anchovy–sardine trade-off, instead of adopting a universal optimum. Recent recruitment estimates were based on an

age-structured population model (de Moor 2014). Early season catch quotas are tested by simulation to ensure robustness in terms of expected catches and uncertainties about the resource dynamics. Harvest limits are adaptively adjusted during the year as catch data are processed (De Oliveira and Butterworth, 2004).

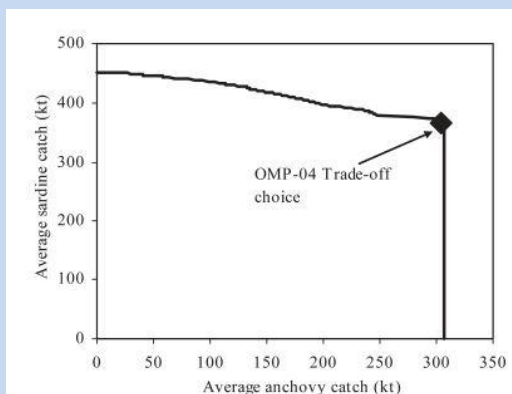

Figure Box 2.6: Trade-off curve between the average annual sardine and average annual anchovy catches, with the point selected for the 2004 operational management procedure (OMP-04) indicated.

Integrated territorial planning is a general and flexible approach to facilitate cooperative planning between neighbouring and sometimes overlapping jurisdictions and vertically from the individual land use plot to the national and supranational levels.

The aim of territorial planning is to promote common interests or reconcile objectives. Integrated territorial planning seeks to respond to jurisdictions that are recognized by specific national legislation and that are hierarchically organized, such as national, subnational, protected area, private and collective communal land (Amler et al., 1999). Applications of Integrated territorial planning often include establishment of multi stakeholder platforms to facilitate spatial planning across areas that do not respond specifically to jurisdictions, such as watersheds, individual ecosystems or areas of influence of development projects. In this context the strong links across the scales need to be considered in the analysis of land or marine area management (Ballinger et al., 2010). Integrated Coastal Zone Management and Integrated Watershed Management are examples of territorial planning in specific contexts that are implemented through cross-jurisdictional agreements between representative state, grass roots or private stakeholders (Alves et al., 2011; Ballinger et al., 2010). As Integrated territorial planning tends to be GIS-based, its key strength lay in its visual products, including thematic maps that can be used across cultures and technical capacities to bridge knowledge systems by presenting both technical information and local knowledge and values.

The **Delphi technique** was developed by the RAND Corporation as a forecasting methodology (Gordon and Helmer, 1964; Linstone et al., 2002). Soon after, it was adapted as a decision tool (Rauch, 1979). Rauch, (1979) defines three relevant types of Delphi; Classical Delphi, Policy Delphi and **Decision Delphi**. The focus of classical Delphi is on forecasting and elicitation; describing the future, while the latter two are focussed on mediating outcomes that influence the future. Classical Delphi may play a role in agenda setting, while Policy and Decision Delphi are particularly appropriate when decision-making is required in a political or emotional environment, or when decisions affect strong factions with opposing preferences. Decision Delphi can be used formally or informally to exploit the benefits of group decision making while attempting to insulate against its limitations (e.g., deference to authority and groupthink). Example applications of Delphi as a decision tool include allocation of national level health funding in the USA (Hall et al., 1992) and setting priorities for the IT industry in Taiwan (Madu et al., 1991). Delphi can work as an informal, subjective decision support model when the decisions are based on opinion, and can be converted to a formal model, when quantitative data are available.

Strategic Environmental Assessment (SEA) is the systematic environmental assessment of policies, plans and programmes (Therivel and Paridario, 2013). SEA can be viewed as a special case of environmental policy evaluation (Crabbé and Leroy, 2008) that falls within the broader field of policy evaluation, but that presents some very specific challenges due to the multiplicity of stakeholders expectations' concerning policies, and the political and thus debatable ground on which evaluations rest (Mermet et al., 2010).

SEA can be considered an evidence-based instrument that adds scientific rigour to policy development and implementation via suitable assessment methods and techniques (Fischer, 2007). SEA is not a decision making tool, heuristic or framework in the sense of many approaches reviewed in this section that seek to identify best or robust decision or trade-offs (e.g., management strategy evaluation). It is an assessment process that provides information to planning, policy or program development. The primary objectives of SEA (UNEP, 2002) include; (i) supporting informed and integrated decision making by identifying the environmental effects of proposed actions, alternatives and mitigation measures; and (ii) contributing to environmentally sustainable development by providing early

warnings of cumulative effects and risks that may not be apparent or require assessment in individual environmental impact assessments (EIA: Du et al., 2012).

SEA is related to *Environmental Impact Assessment (EIA)*, which is a widely used approach to evaluating the impact of projects (usually development proposals or other extractive or resource use plans) on environments, including biodiversity and ecosystem services (Glasson et al., 2013). SEA and EIA are used at different levels of the decision-making hierarchy. The former addresses policies, plans and programmes; the latter focuses on projects (Table 2.3). SEA tends to be more strategic and participatory, operating at higher levels in planning and program development, being more forward-looking, potentially involving methods such as forecasting and visioning (Wang et al., 2006; Du et al., 2012; Liu et al., 2007).

Table 2.3

Summary of differences between SEA and EIA. From Sloomweg (2006).

Strategic Environmental Assessment (SEA)	Environmental Impact Assessment (EIA)
Takes place at earlier stages of the decision making cycle	Takes place at the end of the decision making cycle
Pro-active approach to help development of proposals	Reactive approach to development of proposals
Considers broad range of potential alternatives	Considers limited number of feasible alternatives
Early warning of cumulative effects	Limited review of cumulative effects
Emphasis on meeting objectives and maintaining systems	Emphasis on mitigating and minimising impacts
Broader perspective and lower level of detail to provide a vision and overall framework	Narrower perspective and higher level of detail
Multiple processes, continuing and iterative, overlapping components	Well-defined process, clear beginning and end
Focuses on sustainability agenda and sources of environmental deterioration	Focuses on standard agenda and symptoms of environmental deterioration

Strategic Environmental Assessment is now becoming a more frequently and widely used (Fischer, 2007). Regulations and guidelines for SEA are being proposed in many countries worldwide. For example, in the EU the SEA Directive (2001) requires an environmental assessment for plans and programmes at national, regional and local levels of jurisdiction. Its role in assessing impacts of policies seems less well developed. Increasingly, developing countries are introducing legislation or regulations to undertake SEA – sometimes via modification of environmental impact assessment (EIA) legislation and policies (e.g., China, Belize, Ethiopia) and sometimes via natural resource or sectors laws and regulations (e.g., South Africa, Dominican Republic). In Australia ‘strategic assessments’ aim to analyse the cumulative impacts of multiple stressors on species listed as threatened under the Environment Protection and Biodiversity Conservation Act (EPBC, 1999). The Convention on Biological Diversity (Article 6b and Article 14) (sCBD, 2005) encourages the use of SEA in its implementation (without making it a specific requirement). The Paris Declaration calls for the development of common approaches to environmental assessment generally, and to SEA specifically (www.oecd.org/dac). The CBD Conference of the Parties has endorsed guidelines for EIA and SEA (Decision VIII/28: www.cbd.int/decision/cop/?id=11042) and also developed guidelines for their application in marine areas (Decision XI/18).

Primary strengths of SEA include the potential for integration of environment and development objectives, a reduction in the administrative burden of many small-scale impact assessments, and a reduction in the ‘death-by-a-thousand cuts’ effect of many small impacts because of the explicit consideration of cumulative impacts at a regional scale (Hawke, 2009).

Other benefits include enhancing the role of science-based evidence in supporting decisions at higher strategic policy and planning levels than EIA, the capacity to identify and generate new options, the potential to build public engagement and improved transparency, an increased chance of early problem identification, the promise of trans-boundary cooperation, and clarity around institutional responsibilities.

However, SEA seems to lack an accepted underlying theory and the range of possible approaches that are described as strategic assessment appears almost infinite (Fischer and Seaton, 2002). It lacks a standardised approach and therefore repeatability. While the intent is for SEA and EIA to work together in a hierarchy of tiered instruments (sCBD and Netherlands Commission for Environmental Assessment, 2006) with SEA taking place at a strategic level and EIA taking place at a project level, the reality in some jurisdictions such as Australia is that large SEAs are replacing multiple, project-level EIAs (www.environment.gov.au/node/18607). This creates the real possibility and the perception that SEA provides an avenue for approval or endorsement of large impacts within a single assessment, which is viewed as a negative by some stakeholders.

There are no hard rules about the nature of public consultation under SEA, which opens the method up to minimal or token consultation. Lack of expertise and specialist skills among the general public can lead to power differentials in the process where some stakeholders are well resourced, informed and organized. In most administrations under severe human resource and financial constraints, SEA may be seen as a large administrative burden and impossible to properly manage, audit and enforce. The actual assessment of impacts or benefits on biodiversity and ecosystem services often defaults to the lowest common denominator; usually subjective risk matrix assessments and trend assessment. In 46 SEAs reviewed by the Organisation for Economic Co-operation and Development (OECD), EU and the Japanese Ministry of the Environment (OECD, 2012; Sheate et al., 2001; Ministry of the Environment, 2003) all used subjective, largely data-free assessments of potential impacts on biodiversity and ecosystem services. This finding is supported by other comparative studies that find ‘... evolving SEA practice in Europe demonstrates the tendency to use the simplest available tools’ (Dusik and Xie, 2009). Therivel and Walsh, (2006) observe that modelling has been little used among 200 United Kingdom authorities surveyed, and a survey of SEA practitioners in China found that 92% felt environmental mathematical modelling would be extremely useful, compared with around 60% who felt (risk) matrices, scenarios and expert judgement would be useful (YEPB and Ramboll Natura, 2009), and yet not one mathematical model of biodiversity or ecosystem services is used in the sample of 15 case studies reviewed across Asia. It would appear therefore that the problem is in the lack of available environmental models, not the lack of desire of practitioners to use them. The minimal role of modelling in current applications of SEA highlights an opportunity to expand its use and improve SEA.

Box 2.7: Strategic environmental assessment of hydropower dams on the Mekong River.

In 2009, the Mekong River Commission undertook SEA of twelve proposed hydroelectric mainstream dams on the Mekong river to provide a broader understanding of the opportunities and risks of the development proposals. The Commission is in charge of implementing the 1995 Mekong Agreement for regional cooperation in the Mekong Basin between the governments of Cambodia, Lao PDR, Thailand and Viet Nam. These governments agreed on joint management of their shared water resources to ensure sustainable development, utilization, conservation and management of the Mekong River Basin water and related resources. A number of independent environmental impact assessments (EIAs) that had been prepared in the lead up to the SEA were incorporated into the ‘big-picture’ framework of the SEA. The Commission was responsible for developing the strategic plan, alongside government agencies and experts, taking into consideration power security; economic development and poverty alleviation; ecosystems integrity; fisheries and food security; and social systems in the region. After assessing the baseline status of the fisheries in the area, the potential impacts to both fisheries and the natural aquatic ecosystem functioning under different levels of damming was investigated. Five alternative development scenarios were developed by the Commission and compared to baseline statistics from 2000; i) a ‘definite future’ of already-approved dams; ii) no mainstream dams; iii) 6 (upstream) dams; iv) 9 (up- and midstream) dams; and v) 11 dams. These scenarios represent clusters of projects with cumulative impacts on the Mekong River and surrounding areas. Employing hydrological modelling forecasts, previous literature studies on the distribution and migratory patterns of Mekong river fish species, and expert consultation, predictions of fishery yield impacts under the five damming scenarios were assessed (Figure 2.7). The analysis found that the mainstream projects would fundamentally undermine the abundance, productivity and diversity of the Mekong fish resources, as well as resulting in serious and irreversible environmental damage, losses in long term health and productivity of natural systems, losses in biological diversity, and ecological integrity. The SEA assessed four alternative courses of action for the immediate future, and recommended that all further development of hydroelectric dams be deferred for a period of 10 years. The strengths of this case study included the development of multiple, realistic potential development scenarios; extensive consultation process involving multiple governments, expert workshops, and public involvement; and evaluation of realistic, alternative courses of action. Extensive reporting is available at:

<http://icem.com.au/portfolio-items/strategic-environmental-assessment-of-hydropower-on-the-mekong-mainstream/>

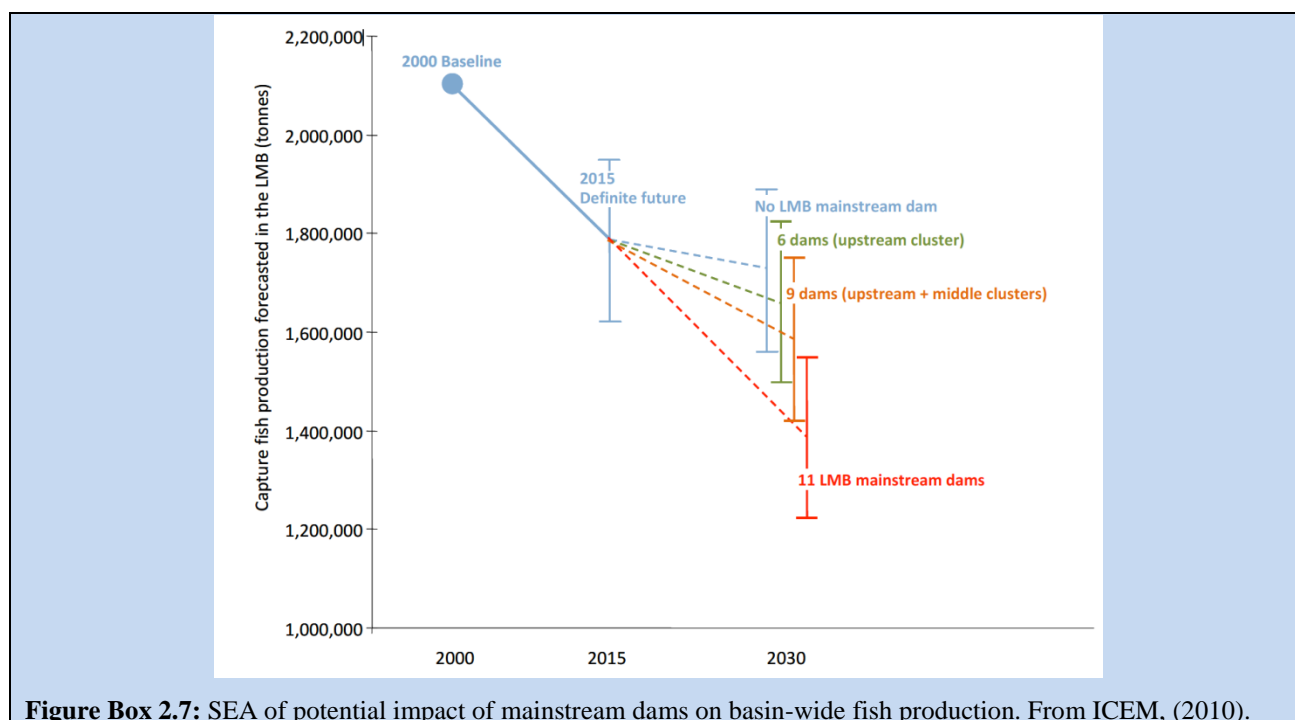

Figure Box 2.7: SEA of potential impact of mainstream dams on basin-wide fish production. From ICEM, (2010).

Open Standards for the Practice of Conservation was developed by Conservation Measures Partnership to provide a conceptual framework and specific tools for successful implementation of conservation projects (CMP, 2013; Margoluis et al., 2013).

The ‘open standards’ refer to ‘standards that are developed through public collaboration, freely available to anyone, and not the property of anyone or any organization’ (Dietz et al., 2010). The Conservation Measures Partnership, which was formed in 2002, is a consortium of non-governmental conservation and donor organisations. The Open Standards for the Practice of Conservation is a product of the Conservation Measures Partnership’s mission to develop, test and promote conservation principles and tools that can credibly assess and improve the effectiveness of conservation actions (CMP, 2011). The Nature Conservancy’s Conservation Action Planning and World Wildlife Fund’s (WWF) Project and Program Management Standards are similar endeavours to develop, adopt, and implement standards for systematic project and program management and monitoring (Moorcroft and Mangolomara, 2012; Margoluis et al., 2013). The Open Standards for the Practice of Conservation has been applied widely because of the large number of member organizations, and because training is provided by the Conservation Coaches Network (CCNet) and its regional franchises are increasingly serving as a mechanism to promote it globally (CMP, 2013).

Dietz (2010, p.425) elaborated the five steps of the Open Standards for the Practice of Conservation, which is based on the project management cycle (Figure 2.6). The essential principles that apply to all of the steps include involving stakeholders, developing and cultivating partnerships, embracing learning, documenting decisions, and adjusting as necessary (CMP, 2013). The standards are assumed to represent the ‘ideal’ conservation decision making and learning process, but it is recognised that in reality standards can be implemented using a variety of tools and guidance, few projects will start at the beginning of these standards, and that each project is different in potentially significant ways.

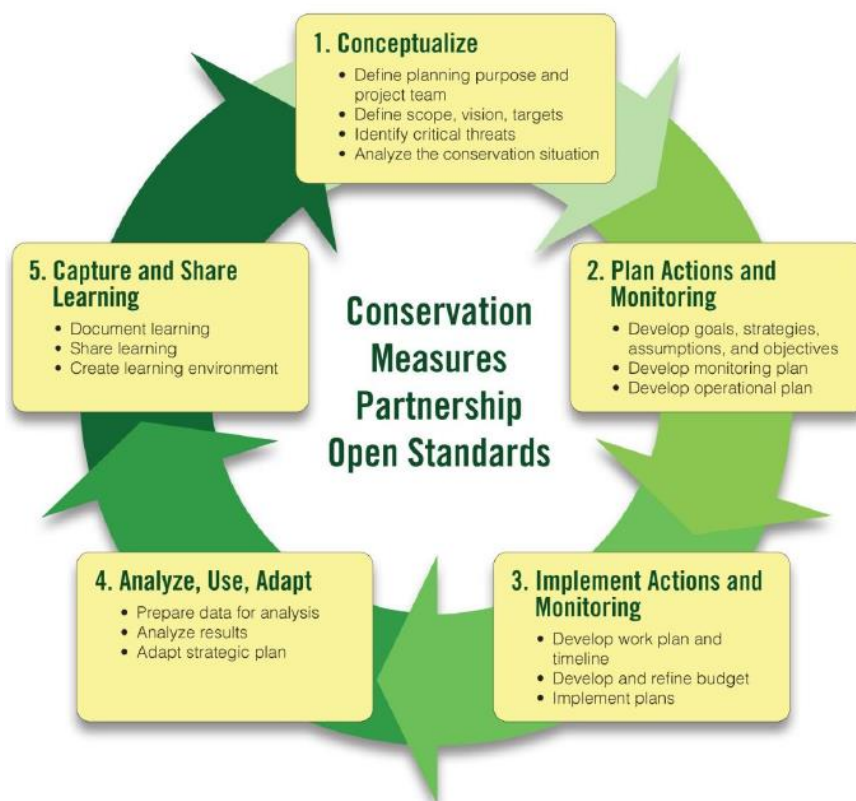

Figure 2.6: Five-step project management cycle of the Open Standards for the Practice of Conservation (Adapted from CMP, 2013).

The Open Standards for the Practice of Conservation provide an over-arching framework that can work with other conservation tools (e.g., MARXAN, systematic conservation planning, structured decision-making) (Schwartz et al., 2012). It is applicable at many scales, across different organization types, and to different priorities within an organization (Lamoreux et al., 2014). A key strength of the Open Standards for the Practice of Conservation is that it is supported by a free software called Miradi Adaptive Management, which uses diagrams (e.g., results chain, Salafsky 2011) wizards, examples, and multiple views. The Miradi allows practical and step-by-step application of the Open Standards for the Practice of Conservation framework (<https://www.miradi.org/about-miradi/>). As of 2012, Miradi has over 5500 users in 167 different countries and been used in over 115 projects of The Nature Conservancy (Schwartz et al., 2012). A criticism of the Open Standards for the Practice of Conservation is that there is the lack of peer-reviewed publications that evaluate its effectiveness and place it in the spectrum of other decision support and planning approaches (Schwartz et al., 2012). While the conceptual foundations of the Open Standards for the Practice of Conservation appear strongly connected to the policy cycle and adaptive management, it is hard to discern a particular theoretical foundation for the approach, compared with other approaches such as structured decision making in which each component appears to arise from sound decision theoretic foundations.

2.3.2.4 Summary of strengths and weaknesses of decision support protocols

The methods and approaches to decision support reviewed in the previous sections vary widely in their assumptions, strengths, weaknesses, complexity, sophistication and flexibility for dealing with the variability in decision contexts (Table 2.4). As with choosing between different types of scenarios and models, a key trade-off when choosing a decision support approach is between simplicity (ease of use) and sophistication (the capacity to capture realism in terms of stakeholder perspectives, risk preferences, behaviour, explicit, hidden and nascent objectives).

Clearly, using only consequence tables or risk matrices has simplicity on its side. Some expertise is required to step people through the process of using such tools properly, but the task is not overwhelming, which may explain why they are used so widely in SEA (Sheate et al., 2001; OECD, 2012). Many ‘classical’ decision theory tools, such as the optimization approaches offer the allure of objective rationality, however, they do not perform well in isolation in many decision contexts because they don’t capture important aspects of human judgement and behaviour under risk and uncertainty (Kahneman and Tversky, 2000), and because socially important aspects of the decision problem commonly must be excluded due to technical constraints (the inability of optimization software to cope with ‘big’ problems that involve many possible options, states of the world, and uncertainties). However, when embedded as a component of a more holistic, deliberative decision process, classical tools such as optimization may still make an important contribution to complex decision making problems (Gregory et al., 2012). The key disadvantage of the more integrative approaches to decision support is the time and human resource overheads associated with running

large, multi-disciplinary, participatory approaches, and the capacity to alienate or generate cynicism if approaches are run poorly, or if there is a sense that engagement of stakeholders is token. In short, big complex decision problems with large consequences clearly demand sophisticated, integrated decision support, and shortcuts in either the technical and participatory aspects of these processes are taken at great peril.

Table 2.4

Overview of assumptions, strengths, weaknesses of decision support protocols described in this chapter, and extra case studies

Method Family Method	Assumptions	Strengths	Limitations	Case study	Case study and General reference	
Methods tailored to multi-objective problems	<i>Consequence tables</i>	Implicitly assumes that users can coherently trade between consequences of actions across multiple objectives on a single arbitrary scale.	Simplicity and usability, internal consistency, can utilize qualitative or quantitative assessment of consequences with respect to multiple objectives. Relatively easy identification of redundant and dominated options.	Does not explicitly consider likelihood of outcomes. Does not provide very sophisticated approach to finding trade-offs. Time or risk preferences not explicitly incorporated.	Water use planning in British Columbia, Canada. Consequence tables were used as part of a larger analysis into the allocation of water to hydroelectric dams, in the face of changing environmental and social values and knowledge of impacts. The consequence table was used to focus stakeholders on evaluating options and to make explicit the trade-offs between objectives.	Case study reference: Failing et al., 2007 General reference: Gregory et al., 2012
	<i>Cost-benefit analysis</i>	Benefits and costs of all values can be measured in a single currency (usually monetary). Preferences are revealed by observed actions or can be elicited.	Relatively simple and transparent. Can use modelled or directly observed benefits and costs.	Doesn't deal well with incommensurable values. Many stakeholders uncomfortable with monetarization.	Planning options to mitigate losses due to coastal erosion in the coastal NSW, Australia were analysed using CBA. The cost benefit analysis found that the most cost effective option was a 'Planned Retreat with Purchased Easements' option, which provides limited compensation for beachfront property owners in return for their agreement to	Case study reference: Balmoral Group Australia, 2014 General reference: Atkinson and Mourato, 2006
	<i>MCD</i>	Explicit separation of cause-effect (likelihood and consequences) and value-based trade-offs. Estimates of likelihood and consequence can be qualitative or quantitative. Commonly uses multi-attribute value theory to describe preferences. Weights assigned using indifference methods	Weightings are a relatively simple way to express preferences for outcomes. Relatively sophisticated approaches exist for eliciting weights. Uncertainty about consequences can be incorporate.	Uncertainty about consequences difficult to incorporate. Most commonly uncertainty is characterised as probabilistic statements about likelihood (commonly under MAVT approaches).	Using MCD to reduce human-wildlife conflict in the UK. Two sets of stakeholders with opposing interests - raptor conservationists and grouse (a gamebird) managers - participated in a MCD exercise to attempt to resolve their management conflicts. Setting explicit objectives and finding commonly favoured management strategies helped to build links between the two groups.	Case study reference: Redpath et al., 2004 General reference: Steele et al., 2009; Burgman, 2005; Diaz-Balteiro and Romero, 2011

Methods tailored to multi-objective problems	<i>AHP</i>	Variant of MAVT designed to reduce elicitation burden. 9-point preference scales to translate ordinal judgements to cardinal judgements. Weights by pairwise comparisons.	Relatively fast and simple to implement in a spreadsheet.	Potentially susceptible to abuse and violations of basic decision theory axioms (but see mAHP approaches to addressing this problem).	Environmental Conflict Analysis in the Cape Region, Mexico. Model was utilized to determine suitability of land for different socio-economic activities and identify the land use pattern that maximized consensus among stakeholders from many	<p>Case study reference: Malczewski et al., 1997</p> <p>General reference: Mendoza and Martins, 2006</p>
	<i>Outranking</i>	Based on behavioural models of decision making. Sequential elimination of options. Weights assigned to objectives without considering range of consequences for each option.	Easy to implement for decision problems with relatively many competing options. Existing user-friendly software. Can deal with qualitative or quantitative consequence estimates.	Appears to fail on some basic axioms of rationality. Requires acceptances of behavioural models of decision making.	Ranking the metapopulation extinction risk of a butterfly species in the Aland islands of Finland. Despite considerable occupancy data, there is high uncertainty in the metapopulation model outcomes (namely, extinction risk) for the Glanville fritillary. However, outranking provided a rank of management scenarios robust to the uncertainty in the model for this case study.	<p>Case study reference: Drechsler et al., 2003</p> <p>General reference: Burgman, 2005</p>
Optimization approaches	<i>Linear Programming</i>	Uses algorithms designed to optimise an objective function under specified constraints. Requires that a linear (or near-linear) relationship exists between actions and their expected consequences.	Computationally quick. Linear relationships are easy to understand.	Inappropriate in many ecosystems, where outcomes for objectives are non-linear in response to actions.	Subsistence farming and the conservation of soil, to avoid erosion in the highlands of Ethiopia. Linear programming was utilised to determine the optimal production strategy to satisfy production goals while minimising soil erosion under a number of behavioural assumptions.	<p>Case study reference: Shiferaw et al., 1999</p> <p>General reference: Chankong and Haimes, 2008</p>
	<i>Stochastic Dynamic Programming</i>	Able to incorporate complex, non-linear, dynamic relationships between management actions and outcomes. Accounts for stochastic events. Allows for optimal approach to differ depending on the state of the system.	Allows complex, realistic relationships between actions and outcomes. Can incorporate effects of stochastic events.	Requires highly detailed knowledge of cause-and-effect pathways in order to incorporate complexity.	Optimal fire management to achieve ecosystem outcomes in South Australia. Stochastic dynamic programming methods were to provide state-dependent decision rules to managers about when to fight fires and when to let them run in order to achieve ecosystem composition objectives.	<p>Case study reference: Richards et al., 1999</p> <p>General reference: Chankong and Haimes, 2008; Minas et al., 2012</p>

Optimization approaches	<i>Goal programming</i>	Developed to handle multiple (usually conflicting) objectives, with each objective given a goal or target value to be achieved and deviations from the set of targets minimised.	Avoids the naïve, binary-style step functions used by LP and SDP. Useful in single-stakeholder settings.	Subject to misuse in multi-stakeholder problems through insincere goal-setting to manipulate outcomes.	Optimising forest management for carbon sequestration in Spain. Goal programming was used to optimise the sometimes conflicting objectives of simultaneously maximising timber harvest and carbon sequestration through forest management practices. Though final solutions were robust to the weightings of the two objectives, they revealed the	Case study reference: Díaz-Balteiro, 2003 General reference: Chankong and Haimes, 2008
Integrative approaches (often subsume other approaches)	<i>Structured decision making</i>	Provides insight to decision makers about how well their objectives may be satisfied by potential alternative courses of action. Assumes all relevant stakeholders can be identified and are willing and able to participate in process. Clarifies divergent values that may underpin irreducible trade-offs. Objectives and performance measures drive the search for management and policy options	Broad approach can be applied to a vast number of situations of different complexities and scales. Handles conflicting values and uncertainty well over more simple analytic tools. Partitions process into smaller steps, simplifying the social and technical components of the problem. Clearly separates facts from values.	Large "human" element, so irresolvable conflicts between stakeholders can make progress impossible. Little guidance on how to undertake the steps within SDM. Requires significant experience of SDM to facilitate a fruitful outcome.	Management of invasive willows in alpine Australia. Scientists worked with land managers to determine the best management strategy under a range of budgets to protect alpine bogs from willow invasion. The process involved developing a state-based dynamic model to describe the invasion of willows, role of wildfire in the ecosystem, and predict the effect of management interventions, as	Case study reference: Moore and Runge, 2011 General reference: Gregory et al., 2012; Keeney, 1982
	<i>Adaptive Management</i>	Sequential decision process, aiming to provide the opportunity to incorporate the role of learning into management programs. Operates on the idea of "continuous improvement" through flexibility in decision making, incorporating new information and re-assessing management actions.	Enables the best decision to be made given the available information at a certain time, as well as improving on that decision (or strengthening certainty in the original decision) over time as more information is gathered.	Stakeholders often reluctant to commit to long-term monitoring of management outcomes (or unable to, due to unpredictable funding).	Adaptive management of sika deer populations in North Japan. Experts, hunters and government stakeholders identified four action plans for controlling over-abundant sika deer on Hokkaido. By varying harvest targets and improving estimation of population size, management was able to meet the objectives of maintaining the deer population at a level that posed little threat to crops and forests.	Case study reference: Kaji et al., 2010 General reference: Oglethorpe, 2002; Salafsky et al., 2001
	<i>Management strategy evaluation</i>	Simulation models within an adaptive framework for evaluating management options under conflicting objectives. Rather than prescribing an optimal strategy, MSE provides managers with the options and explicit trade-offs from which a rational decision can then be made.	Good at revealing trade-offs in performance across objectives. Explicitly and transparently considers uncertainty in both the assessment of the state of the environment and the implementation of management strategies. Encourages stakeholder input.	Technical demands in incorporating real-world complexity and reliance on computer simulations make MSE inaccessible.	Balancing fishery and conservation objectives in line fishing on the Great Barrier Reef, Australia. Stakeholders with competing objectives participated in a MSE to identify objectives and performance indicators of the system. Metapopulation and fishing simulation models were used to identify which often management scenarios maximised performance targets for the most stakeholders.	Case study reference: Mapstone et al., 2008 General reference: Bunnefeld et al., 2011; Holland, 2010; Rademeyer et al., 2007

Integrative approaches (often subsume other approaches)	<i>Scenario planning</i>	Multiple potential futures arise from a range of conditions and explicitly considering them may change current decisions. Development of futures can utilise qualitative and quantitative information. Does not assess probability of futures.	Easily integrated into more complex decision support tools, such as MSE and SDM. Promotes consideration of a wide range of possible futures, (rather than just likely ones); the assumptions behind them; and the uncertainties inherent in them.	Doesn't account for, or enable assessment of, the probability of the futures. May therefore give too much consideration to highly unlikely events. Cannot accommodate/predict futures that are not explicitly considered.	Participatory scenario planning in the protected area of the Doñana social-ecological system in southwestern Spain. Stakeholders in conflict over the future of the region - for conservation versus development - participated in a scenario planning process to identify objectives for management of the protected area. Four futures were identified and backcasting was used to determine what actions and trade-offs stakeholders were willing to make in the present to secure the preferred future.	Case study reference: Palomo et al., 2011 General reference: Börjeson et al., 2006; Chermack, 2011; Schoemaker, 1993; Schoemaker, 1995; Peterson et al., 2011
	<i>Strategic Environmental Assessment</i>	Systematic and evidence-based assessment of environmental policies and programmes provides scientific rigour to the policy process and improves outcomes. Assumes assessment of projects at larger scales can provide better outcomes than multiple, smaller, individual actions.	Facilitates integration of environmental and development objectives. Reduces both administration burden and cumulative impacts of multiple small projects by assessing policies at a regional scale. Encourages transparency and public engagement.	Broad scales and numerous alternatives make for complex-to-analyse problems with high levels of uncertainty. Data collection difficult at such scales, often leading to further uncertainty. Public input may lead to reverse outcomes due to lack of expert knowledge and power differentials favouring well-resourced stakeholders. Often seen as infeasible under resource-stressed administrations.	Assessment of cumulative impacts of housing, transport and mining infrastructure in the Perth and Peel regions of Western Australia, Australia. For a 8000km ² region of Western Australia, where urban expansion is planned to accommodate another 3M people, the biodiversity impacts of infrastructure were investigated as using distribution models of species' and communities' under 4 development scenarios.	Case study reference: Whitehead et al. 2015 General reference: Fischer and Onyango, 2012; Fischer, 2010
	<i>Integrated Territorial Planning</i>	Requires cooperative planning between neighbouring/overlapping jurisdictions and across multiple scales. Deals with jurisdictions that are recognized by specific national legislation and aims to promote common interests or reconcile conflicting objectives among these territories.	Strong visual appeal as ITP often produces thematic maps that can be used to communicate across knowledge systems, bridging differences in culture and technical proficiencies. Incorporates both social and technical knowledge.	Requires cooperation across administrative boundaries, which are often not designed to interact.	Spain's Integrated Coastal Zone Management Strategy covers multiple territories across the country's coastline. Both sustainable development and integrated management objectives were developed to improve ecosystem health and socio-economic development goals. Coordination among the administrative levels is identified as integral to facilitating territorial coherence	Report for Chapter VI of the Recommendation of the European Parliament and of the Council concerning implementation of Integrated Coastal Zone Management in Europe. http://ec.europa.eu/ourcoast/download.cf

2.3.3 Dealing with uncertainty in decisions

Uncertainty impacts on all phases of the policy cycle. In setting policy agendas, uncertainty may be invoked as a reason to pursue or avoid particular policies, or to motivate policy reform. For example, uncertainty about the magnitude of climate change impacts on ecosystems and livelihoods may be used to invoke a precautionary approach to energy policy. Uncertainty impacts on policy design and implementation because, for example, there is often large epistemic uncertainty about benefits or impacts expected to arise from a particular policy or implementation strategy. Post-hoc policy evaluation is often hampered by imperfect measurement of the outcomes of policy implementation that generates uncertainty around evaluation of benefits and costs of policies and plans.

Uncertainties arise for a variety of reasons and take a variety of forms; some reducible and some irreducible (Wintle et al., 2010; Regan et al., 2002). Uncertainty can be addressed in a variety of ways during the agenda setting and policy design and implementation phases.

Exploratory scenarios provide an excellent means of characterising possible futures, and exploring their implications (Chapter 1, Chapter 3; Schwartz, 1995). A key step in scenario planning is the process of exploring the robustness of planning options to a broad range of possible futures (Schoemaker, 2012), which can be viewed as a heuristic for dealing with uncertainty.

Scenario planning can be viewed as arising from the discipline of future studies (Bell, 2003; Cook et al., 2014), which subsumes a range of other agenda-setting and policy support activities dealing with uncertainty about the future such as horizon scanning (Sutherland and Woodroof, 2009), causal layered analysis (Inayatullah, 2004), visioning (Groves et al., 2002), emerging issues analysis (Molitor, 2003), back casting (Robinson, 2003), and several others that cannot be described in detail here.

A multitude of mathematical methods exist for dealing with uncertainty in choice problems that can be useful in policy design and implementation decisions. They include Stochastic Dynamic Programming (Section 2.3.2.2), robust optimization (Ben-Tal and Nemirovski, 2002), Info-gap decision theory (Ben-Haim, 2006), and sensitivity analysis (Wallace, 2000).

An advantage of mathematical decision support approaches for dealing with uncertainty is that the nature of the uncertainty being addressed is clear and precisely defined, as is the role of models. Models describe the system being managed and the nature and magnitude of the uncertainty. In addition to identifying robust options, application of formal uncertainty analyses can highlight which uncertainties are most important to resolve and which are inconsequential (Moore and Runge, 2012). Such analyses provide a strong motivation and guidance for investing in reduction of critical uncertainties. The primary impediment to the use of these approaches is the relatively high technical expertise needed and limitations on the complexity and size of the decision problem that can be handled in practice.

Most of the commonly used mathematical approaches to characterising and dealing with uncertainty in decision-making focus on epistemic and stochastic uncertainties, assuming rational, utility maximizing behaviour from decision makers. However, many environmental decision problems are characterised by high social complexity due to multiple stakeholders with diverse values operating in uncertain and shifting administrative, economic, political, and legal environments (Balint et al., 2011). Such problems can seldom be fully characterised and analysed with mathematical approaches to uncertainty. A lack of specificity about objectives and diversity in decision-maker and stakeholder perceptions, knowledge, values and attitudes all introduce *decision uncertainty* (Chapter 1; Maier et al., 2008). Decision support methods that address subjective and intangible uncertainties (e.g., Runge et al., 2011a; van der Sluijs et al., 2005) are thus critical in supporting policy in most decision contexts. Such processes often require deliberation among decision makers and stakeholders to allow learning throughout the decision-making process. Participatory planning and adaptive management approaches exist that foster deliberation around epistemic, stochastic, and decision uncertainty in ecosystem management (Susskind et al., 2012). A key challenge to dealing with uncertainty in participatory decision making is communicating to non-technical participants. A range of guiding documents exist to help provide a language for communicating uncertainty (Wardekker et al., 2008; Petersen et al., 2013) and to promote the use of graphical methods to help convey the nature and magnitude of uncertainty to a broader audience in a way that is more relevant to the decision at hand (McInerny et al., 2014).

2.4 Ingredients for success; matching approaches to decision needs

Reflecting on the sample of policy, planning and management support approaches and case studies reviewed here, a couple of observations about success emerge.

A defining feature of the documented successful applications of decision support appears to be the level of commitment and involvement of decision analysts or facilitators for the duration of the decision process.

Examples of decision processes were documented that ranged from highly participatory, deliberative, mostly non-technical exercises (Box 2.2, 2.3), to more technical exercises (Box 2.4), and combinations of the two (Box 2.5).

All had very strong commitment and support from decision analysts, modellers, and/or facilitators. These people might be considered ‘champions’ of their given decision support approach or method, and like champions of change, they are essential for successful use of scenarios and models in formal decision processes (Guisan et al., 2013).

Section 2.3 described a sample of decision support approaches and methods under broad families. Acknowledging that the approaches and case studies described in that section are based on a small sample of published applications in decision support (91 case studies in total), some generalizations are nonetheless supported regarding the sorts of decision approaches that lend themselves to application in particular decision-making contexts. While some aspects of this relationship between decision context and methods are self-evident; for example, the use of Multi Criteria Decision Analysis in decisions involving multiple stakeholders or decision makers, other patterns emerge which may be less obvious *a priori*. For example, it appears that for the most part, sequential decision approaches tend primarily to address single-objective problems, while regional-scale, multi-objective problems tend not to be addressed using sequential, dynamic, adaptive management approaches (Westgate et al., 2013). This may be simply that regional-scale, multi-stakeholder decisions problems tend to be once-off decisions with no plan or program for future changes, or because the inherent complexity of such decisions precludes analysing them as sequential decision problems, even if they are so in reality.

Some lessons can be learned from the successful application of decision support, scenarios and models at multiple scales. At the global scale, Section 2.3.1 describes an example in which scenarios of future land use (driven by consumption) and climate change, supported by a model that estimate the biodiversity outcomes of land use change (GLOBIO), were used to motivate policy decisions, including the setting of Aichi biodiversity targets. This is not to claim that the targets themselves arose naturally from the prediction of a model, but simply that the analysis set the agenda by providing evidence about the scale of the problem and the consequences of not acting. Some attributes of this scenario and modelling work give some clues as to why this analysis had an impact on policy. Firstly, the scenario and modelling work was embedded in the institutional frameworks from which the relevant policies (e.g., Aichi biodiversity targets) arose. For that reason, the analysis had legitimacy and trust among many of the stakeholders and decision makers. Secondly, the work was timely and tailored to the policy problem. The evolution of the relevant policies have allowed sufficient time, and been sufficiently transparent such that the analysis products could be well tailored to the policy needs. The analysis was at an appropriate scale, it analysed an appropriate range of scenarios and provided outputs that were interpretable and motivating to policy makers, and it was credible; based on the best available science and modelling approaches at the time.

Reflecting on another example at a much finer scale, the Glen Canyon dam non-native fish management problem (Box 2.5; Runge et al., 2011b) provides an excellent example of matching the decision framework, intervention scenarios and models of biodiversity impacts to a complex decision need. The problem involved multiple value and knowledge systems (western and First Nations), multiple jurisdictions (USA governments and First Nations governments) and multiple sectors and stakeholders (military, wildlife management, water management, recreational fishers). This problem also involved high ecological complexity including introduced species, threatened species and a regulated river network. This decision context demanded a sophisticated decision support framework, dedication of decision support facilitators, a tailored set of intervention scenarios, and a suite of models to describe the biodiversity and ecosystem service implications of different scenarios and decisions. Adopting a structured decision making approach seems justified based on the decision context and vindicated given the success of the biodiversity outcome and stakeholder acceptance.

Decision support case studies utilizing the methods and approaches described in Section 2.3 were categorized according to decision context variables. An extract from that classification is provided at Table 2.5, with extra case study examples and guiding texts. While this table cannot be viewed as a comprehensive alignment of methods and decision contexts, it provides a framework in which to consider a choice of decision support approaches.

Table 2.5

Decision support approaches and methods assessed against the decision context attributes defined in Section 2.2.1. Attributes are measured in the units described in Table 2.1. The extent to which a particular decision support method or approach is relevant to a particular level of a context variable was subjectively assessed by the authorship group and invited experts. As such, they should be considered at best indicative of the context in which methods *have been* applied and not where they *could* be applied. The table presented here is a summary of the method-by-decision attribute spreadsheet developed by the authors for the IPBES scenarios and models expert group (Deliverable 3c) and the IPBES deliverable on policy and decision tools (Deliverable 4c).

Method Family	Method	Policy cycle	Governance					Decision			Stakeholders		Information			Ecology				Scale				Case studies and references			
			Actors	History	Legitimacy	Sectors	Participation	Decision time horizon	Decision frequency	Objectives	Values	Knowledge system	Scientific knowledge	Data availability	Scientific capacity	Heterogeneity	Diversity	Flows across landscape	Stochasticity	Cross-scale dynamics	Temporal extent	Temporal grain	Spatial extent	Spatial grain	Case study	Case study reference	General reference
Methods tailored to multi-objective problems	<i>Consequence tables</i>	D,I	*	*	*	*	*	S	O	S	H	H	L	L	L	*	*	W	LP	W	*	*	*	*	Water use planning in British Columbia, Canada.	Failing et al., 2007	Gregory et al., 2012
	<i>Cost-benefit analysis</i>	D,I	*	*	*	*	*	S	O	S	H	H	L	H	L	*	*	*	LP	W	*	*	*	*	Planning options to mitigate losses due to coastal erosion in the coastal NSW	Balmoral Group Australia, 2014	Atkinson and Mourato, 2006
	<i>MCDA</i>	D,I	*	*	*	M	P	*	O	M	*	*	L	L	L	*	*	*	*	*	*	*	*	*	Using MCDA to reduce human-wildlife conflict in the UK.	Redpath et al., 2004	Steele et al., 2009; Burgman, 2005; Diaz-Balteiro and
	<i>AHP</i>	D,I	*	*	*	M	P	S	O	M	*	*	L	H	H	*	*	W	LP	W	*	*	*	*	Environmental Conflict Analysis in the Cape Region, Mexico	Malczewski et al. 1997	Mendoza & Martins 2006
	<i>Outranking</i>	D,I	*	*	*	M	P	S	O	M	*	*	L	L	L	*	*	W	LP	W	*	*	*	*	Ranking the metapopulation extinction risk of a butterfly in the Aland islands.	Dreschler et al., 2003	Burgman, 2005
Optimization approaches	<i>Linear Programming</i>	D, I	*	H	*	S	E	*	O	S	H	H	H	H	H	*	S	W	LP	W	*	*	*	*	Avoiding erosion in the highlands of Ethiopia.	Shiferaw and Holden, 1999	Chankong and Haimes, 2008
	<i>Stochastic Dynamic Programming</i>	D, I	*	H	*	S	E	*	O	S	H	H	H	H	H	*	S	W	HU	W	*	*	*	*	Optimal landscape reconstruction for an endangered Australian bird.	Westphal et al., 2003	Chankong and Haimes, 2008; Minas et al., 2012
	<i>Goal programming</i>	D, I	*	H	*	S	E	*	O	S	H	H	*	H	H	*	S	W	*	W	*	*	*	*	Optimising forest management for carbon sequestration in Spain.	Diaz-Balteiro and Romero, 2003	Chankong and Haimes, 2008

Integrative approaches (often subsume other approaches)	Scenario planning	Decision context attributes																				Study description	Author(s)	Year				
		A	D	I	*	*	A	M	P	L	*	M	*	*	H	H	L	*	*	*	*				*	*	D	*
	A,D,I	*	*		A	M	P	L	*	M	*	*	H	H	L	*	*	*	*	*	*	D	*	km	Participatory scenario planning in the protected area of the Doñana social-ecological system.	Palomo et al., 2011	Börjeson et al., 2006; Chermack, 2011; Schoemaker, 1993; Schoemaker, 1995; Peterson et al., 2011	
	A,D,I	*	*	*	*	*	*	*	*	*	*	*	*	*	H	*	*	*	*	*	*	*	D	*	km	Management of invasive willows in alpine Australia.	Moore and Runge, 2011	Gregory et al., 2012; Keeney, 1982
	D,I,R	*	*	*	*	*	*	L	R	*	*	*	H	H	H	*	*	*	*	*	*	*	D	L-R	km	AM of sika deer populations in North Japan.	Kaji et al., 2010	Oglethorpe, 2002; Salafsky et al., 2001
	D,I,R	*	H	*	S	*	L	R	S	*	H	H	H	L	*	*	*	*	*	*	*	*	D	L-R	km	Balancing fishery and conservation objectives in line fishing on the Great Barrier Reef.	Mapstone et al., 2008	Bunnefeld et al., 2011; Holland, 2010; Rademeyer et al., 2007
	A,D,I	*	N	A	M	P	L	*	M	*	*	H	H	H	*	*	*	*	*	*	*	*	D	L-R	km	Assessing the impacts of future developments in the Parth-Peel region.	Whitehead et al., 2015	Fischer and Onyango, 2012; Fischer, 2010
	D,I,R	*	*	A	M	*	L	*	M	D	D	*	*	H	*	*	*	*	*	*	*	*	L-R	*	A plan to integrate landowner contact programs with landscape goals of blue oak	Schwarz et al., 2012	Schwarz et al., 2012	
	A,D,I	*	N	A	S	P	L	*	M	*	*	H	H	L	*	*	*	*	*	*	*	*	D	L-R	km	Spain's Integrated Coastal Zone Management Strategy	http://ec.europa.eu/ourcoast/download.cfm?fileID=1323	

An asterisk (*) indicates that the method is relevant at any level of the decision context attribute (e.g. can be applied at all spatial scales).

2.5 The role of scenarios and models in decision support

Decision support needs of policy makers and managers are driven by the decision context (Section 2.4). In the early phases of a decision process, the knowledge needs of that process are determined, including the decision support framework, and types of scenarios and models that will best satisfy those needs. The decision support protocol chosen for a given decision problem will determine whether and which scenarios and models can be used.

The capacity of different decision support frameworks, protocols and approaches to utilize scenarios and models varies greatly. At one extreme, the simplest risk analysis approaches such as consequence tables (Section 2.3.2.1) can utilize model predictions of consequences for various objectives under candidate actions, but there is little scope within a consequence table to play out multiple scenarios about possible futures (although the candidate actions can themselves be viewed as simple intervention scenarios). In contrast, the more sophisticated, integrative approaches such as structured decision making, management strategy evaluation, or SEA (Section 2.3.2.3) are amenable to utilizing both intervention and exploratory scenarios and a great variety of models describing various aspects of biodiversity, ecosystem services and human behaviour.

Notwithstanding the role of scenarios and models generated outside decision processes for the purposes of improving knowledge and setting new policy agendas, the choice of scenarios and model outputs for a given decision or assessment should be determined by a clear articulation of the objectives of the decision or assessment. The importance of articulating clear and measurable objectives is emphasised in the decision science literature (Gregory et al., 2012), and a number of tools exist to assist in articulating objective, such as objectives hierarchies. The most common problem that arises when choosing scenarios, and aligning the outputs (response variables) of models with the fundamental objectives of an assessment or decision, is that objectives have not been clearly articulated, or they are embodied in vague statements such as ‘ensuring a sustainable future for Springfield’ for which there may be a huge set of relevant model outputs or indicators.

Another common impediment to choosing model outputs that are proximal to fundamental objectives is that the measures prescribed in the objective statement are impossible or highly impractical to model. For example, a regional level objective to secure all remaining mammals in the Amazon basin while increasing economic opportunities for local peoples could conceivably be supported by models of the population viability analyses of all mammals and socio-ecological models of local livelihoods under a range of future climate, land-use and intervention scenarios (e.g., Wintle et al., 2011). However, it is highly unlikely that population viability analyses for every Amazon Basin mammal could be constructed in time to influence any decision process. For this reason, surrogate model outputs that can be developed within time, budgetary, and expertise constraints are commonly used to approximate the ideal measure of the fundamental objective.

For terrestrial ecosystems at almost all spatial scales, one of the most commonly used surrogates of biodiversity are species distribution models and various aggregations of those models. Species distribution models are appealing for the reason that observation data and mapped environmental variables are readily and freely available, the technology to fit and evaluate species distribution models is readily available and easy to use, and large numbers of species can be processed rapidly. With the many benefits of distribution modelling come many limitations and drawbacks that are well documented (Zurell et al., 2009; Fordham et al., 2011; Guisan and Thuiller, 2005). For the purposes of characterising and predicting long-term biodiversity persistence they are a useful, if blunt instrument. They do not adequately characterise many of the spatial and temporal processes that mediate persistence or extinction in changing environments. For example, failure to explicitly deal with dispersal limitations, competition and predation, or plasticity and evolution of thermal and other niches, they may be missing much that is important in the extinction process. However, by representing spatial and temporal variation in the availability of suitable habitat, they provide a distal surrogate for species persistence over medium to long time-frames. If combined with some other coarse analyses (e.g., Carroll et al., 2010) that bring consideration of spatial processes, they may provide some useful information about the relative merits of alternative conservation options under environmental and land-use change. While it is desirable for model outputs to directly reflect the fundamental objectives of a given assessment of decision problem, in many instances it will not be possible, and in such instances surrogate outputs (e.g., species distribution models) are often better than nothing. Careful consideration of exactly what value model outputs bring to an assessment or decision problem is a necessary ingredient for successful integration at the decision/modelling interface (Addison et al., 2013).

The need for scenarios is generated at the ‘assessment and decision support interface’ (See Figure 1.3 in Chapter 1) given the assessment/policy/planning/management problem at hand. For example, if a coastal management body needs to make decisions about where to allow housing development, they may need carbon emissions scenarios to underpin modelling of sea-level rise in their region and to characterise uncertainty about future sea-levels relating to emissions. A regional biodiversity assessment may require human population growth and land-use change scenarios to inform biodiversity models used to make projections of biodiversity change over several decades (Bomhard et al., 2005). Two broad classes of scenarios are described in Chapter 3; exploratory scenarios and intervention (target-seeking and policy screening) scenarios. Exploratory scenarios are used to explore the sensitivity of response variables (e.g., species persistence or fresh water availability) to a range of possible futures. How exploratory scenarios are

determined and how many can or should be considered is open to the interests, concerns, and imagination of the participants in any given assessment or decision problem. Scenarios can be generated by asking; ‘What future contingencies are likely to impact on the environmental assets, goods and services from our region that we value?’ or through more formal or structured means of scenario elicitation (Carpenter et al., 2006).

Exploratory scenarios have been applied many types of assessments at all spatial scales from local to global (Alkemade et al., 2009; MA, 2005). Intervention scenarios represent possible or anticipated futures arising under a set of specified interventions. Interventions can take the form of policy options, planning options, or management actions and should be specified within realistic social and economic constraints so that they can be considered plausible futures given a certain policy pathway (e.g., Sandker et al., 2009). While intervention scenarios fit most naturally in the domain of decision analysis, they also play a role in policy design and implementation (see Chapter 1).

2.6 Barriers and knowledge and capacity-building needs

Ingredients for successful use of decision support frameworks, scenarios and models in decision making are often missing in big environmental decision problems, creating barriers to adoption. A key ingredient that can be hard to obtain in decision problems is the dedication and continuity of involvement of decision support facilitators and modellers in close collaboration with decision makers throughout decision making processes.

There is a mismatch between the preponderance of academic and theoretical studies around scenario development, modelling and decision support approaches, and the relatively small number of documented case studies that present successful application of scenarios and models in decision making in the environment sector. This is especially the case at the broader regional and global scales.

It is hard to imagine that the relatively small number of documented successful examples of modelling and scenario analysis in decision-making is due solely to a lack of champions. Examples of successful application of formal decision approaches such as Multi Criteria Decision Analysis and scenario planning (often using scenarios and models) abound in other sectors such as manufacturing, business, and the military. There appears to be a particular impediment to wider application of such approaches in biodiversity and ecosystem service policy design and implementation. It may relate to the complexity of socio-ecological systems, a general lack of trust in data and measurement methods, lack of good quality data, lack of willingness to invest in collecting good quality and relevant data, or a lack of willingness to invest the time and financial resources necessary to ensure successful application of scenario analysis, modelling and decision support in environmental decision problems.

Access to relevant data and models is an issue recognized at all scales (Dusik and Xie, 2009). This issue can be partly addressed by data and interface development (addressed in Chapter 7 and 8), though the reality is that insufficient financial resources are allocated to collecting data and building models relevant to most decision problems, irrespective of the magnitude of potential impacts.

For example, assessment of the potential impacts of 11 new dams on the Mekong river involved almost no new data collection, but instead relied on synthesis of sparse existing data (Box 2.7). For this reason, model outputs often fail to meet decision-making needs. This can be partly addressed by improving communication and expectations about the capacity of models to deliver the information relevant to decisions, and by improving investment in data collection, and the capacity of models to deliver what is required, though training, technical advances and standardization of best practice (Peer et al., 2013).

A lack of appreciation of the potential role of decision support, scenarios and models on behalf of decision makers is another impediment to uptake. This appears to be partly due to a lack of trust in modellers, models and scenarios, partly due to a lack of education about the potential benefits of decision support tools, which may be due to a lack of exposure to working examples that highlight the benefits to decision makers of engaging with decision support tools and practitioners.

These problem can be exacerbated by a lack of data to underpin the models and scenarios of most interest to policy makers and managers, a lack of willingness on the part of modellers to engage fully in real-world decision problem and develop the most relevant scenarios and models for the problem at hand, a lack of transparency in approaches to modelling and scenario development, and complex political agendas that are not amenable to the transparency ideally associated with good modelling and scenario analysis.

A subset of these problems can be overcome through improved communication and better documentation of successful application of scenarios, models and decision support (Gibbons et al., 2008). Exploration of methods to improve the credibility of model predictions by collection of empirical evidence demands further attention and resources. The capacity of models to sensibly characterise uncertainty is a key component of their credibility, indicating an important area of research and development in modelling research. Increased collaboration between modellers and decision makers will lead to increased trust, better and more relevant scenarios and models, and a culture of decision support based on scenarios and models that is robust to complex political agendas.

Capacity in scenario analysis and modelling varies geographically. In relatively wealthy countries, scenario development and modelling skills among environmental professionals are low relative to the number of assessment and policy implementation processes that would benefit from the injection of such skills. This problem is magnified in developing countries where, arguably, there is weaker environmental governance, more pressing environmental impacts and less resources available to address them, including resources invested in scenario analysis and modelling skills.

The challenge of increasing uptake of decision support approaches is, in part, a cultural one. The capacity of modellers and decision analysts to influence decision processes in a positive way is impaired by communication challenges across disciplinary divides, and the fact that much of the skill base resides in academic institutions, for which there are few tangible rewards for being involved in real decision processes.

Making scenario development, modelling and decision processes genuinely participatory bring cultural challenges and benefits. A key benefit is that participatory decisions and plans are more likely to be accepted and adopted by those who felt empowered by participating in the decision process.

Cynicism about scenarios, modelling and decision support may partly exist due to a sense among public and stakeholders that these tools are used by authorities and experts to maintain, rather than share power. This attitude may exist partly due to a lack of genuine participatory modelling, scenario and decision processes, and could be partly mitigated by increasing the prevalence of genuinely participatory scenarios, modelling and decision processes. There may be a role for IPBES in facilitating and promoting a network of participatory scenario, modelling and decision support practitioners to build capacity globally.

Cultural challenges extend to negotiating political forces that may not be completely comfortable with 'handing over' complex and sensitive decisions to technocrats using systems that policy makers do not fully understand or trust, or they may be uncomfortable with the level of transparency about motivations, values and scientific facts that decision support brings to decision making. This implies several key challenges. There is the challenge of educating policy makers to understand that involvement in decision processes does not have to mean relinquishing power. Convincing policy makers to engage with decision support requires conveying the notion that decision support can judiciously utilize models and scenarios can help reduce complexity, distil true differences of opinion and values from linguistic ambiguities or confusion, increase mutual understanding of each other's values, and reduce conflict.

References

- EPBC Act, 1999: Environmental Protection and Biodiversity Conservation Act, 1999. Canberra, ACT
- Adam, M.S., Sharma, R. and Bentley, N., 2013: Progress and Arrangements for Management Strategy Evaluation Work of Indian Ocean Skipjack Tuna. Reading, UK.
- ADB, 2010: National Performance Assessment and Subregional Strategic Environment Framework in the Greater Mekong Subregion. Manila, Philippines.
- Addison, P.F.E., Rumpff, L., Bau, S.S., Carey, J.M., Chee, Y.E., Jarrad, F.C., McBride, M.F. and Burgman, M.A., 2013: Practical solutions for making models indispensable in conservation decision-making. *Diversity and Distributions*, **19**(5-6): 490-502.
- Alkemade, R., Van Oorschot, M., Miles, L., Nellemann, C., Bakkenes, M. and ten Brink, B., 2009: GLOBIO3: A Framework to Investigate Options for Reducing Global Terrestrial Biodiversity Loss. *Ecosystems*, **12**(3): 374-390.
- Alves, F.L., Coelho, C., Coelho, C.D. and Pinto, P., 2011: Modelling Coastal Vulnerabilities – Tool for Decision Support System at Inter-municipality Level. *Journal of Coastal Research*, **SI 64**: 966-970.
- Amler, B., Betke, D., Eger, H., Ehrich, C., Kohler, A., Kutter, A., Lossau, A.v., Müller, U., Seidemann, S., Steurer, R. and Zimmermann, W., 1999: Land Use Planning Methods, Strategies and Tools. Eschborn.
- Ananda, J. and Herath, G., 2009: A critical review of multi-criteria decision making methods with special reference to forest management and planning. *Ecological Economics*, **68**(10): 2535-2548.
- Arrow, K.J. and Lind, R.C., 1970: Uncertainty and the Evaluation of Public Investment Decisions. *The American Economic Review*, **60**(3): 364-378.
- Atkinson, G. and Mourato, S., 2006: *Cost-benefit analysis and the environment: recent developments*.
- Baird, D. and Milne, H., 1981: Energy Flow in the Ythan Estuary, Aberdeenshire, Scotland. *Estuarine, Coastal and Shelf Science*, **13**(4): 455-472.
- Baird, D. and Ulanowicz, R.E., 1989: The Seasonal Dynamics of The Chesapeake Bay Ecosystem. *Ecological Monographs*, **59**(4): 329-364.
- Baird, D., McGlade, J.M. and Ulanowicz, R.E., 1991: The Comparative Ecology of Six Marine Ecosystems. *Philosophical Transactions of the Royal Society of London B: Biological Sciences*, **333**(1266): 15-29.
- Baker, J.P., Hulse, D.W., Gregory, S.V., White, D., Sickle, J.V., Berger, P.A., Dole, D. and Schumaker, N.H., 2004: Alternative Futures for the Willamette River Basin, Oregon. *Ecological Applications*, **14**(2): 313-324.
- Balint, P.J., Stewart, R.E. and Desai, A., 2011: *Wicked environmental problems: managing uncertainty and conflict*. Island Press.
- Ballinger, R., Cummins, V. and Smith, H., 2010: Implementing ICZM: The experience of Northwest Europe. *Ocean and Coastal Management*, **53**(12): 725-726.
- Bedford, T. and Cooke, R., 2001: *Probabilistic Risk Analysis: Foundations and Methods*. Cambridge, Cambridge University Press.
- Bell, W., 2003: *Foundations of Futures Studies: Human Science for a New Era: History, Purposes*. New York, USA, Knowledge.
- Belton, V. and Gear, T., 1983: On a short-coming of Saaty's method of analytic hierarchies. *Omega*, **11**(3): 228-230.
- Ben-Haim, Y., 2006: *Info-gap decision theory : decisions under severe uncertainty*. Second ed. Oxford, UK, Oxford Academic Press.
- Ben-Tal, A. and Nemirovski, A., 2002: Robust optimization—methodology and applications. *Mathematical Programming*, **92**(3): 453-480.
- Bennett, J. and Blamey, R., 2001: *The Choice Modelling Approach to Environmental Valuation*. Cheltenham.
- Berger, P.A. and Bolte, J.P., 2004: Evaluating the Impact of Policy Options on Agricultural Landscapes: An Alternative-Futures Approach. *Ecological Applications*, **14**(2): 342-354.
- Biggs, R., Raudsepp-hearne, C., Atkinson-palombo, C., Bohensky, E., Boyd, E., Cundill, G., Fox, H., Ingram, S., Kok, K., Spehar, S., Tengö, M., Timmer, D. and Zurek, M., 2007: Linking Futures across Scales: a Dialog on Multiscale Scenarios. *Ecology and Society*, **12**(1): 17 pages.

- Billionnet, A., 2013: Mathematical optimization ideas for biodiversity conservation. *European Journal of Operational Research*, **231**(3): 514-534.
- Bohensky, E.L., Reyers, B. and Jaarsveld, A.S.V.A.N., 2006: Future Ecosystem Services in a Southern African River Basin: a Scenario Planning Approach to Uncertainty. *Conservation Biology*, **20**(4): 1051-1061.
- Bolte, J.P., Hulse, D.W., Gregory, S.V. and Smith, C., 2006: Modeling biocomplexity - actors, landscapes and alternative futures. *Environmental Modelling & Software*, **22**(5): 570-579.
- Bomhard, B., Richardson, D.M., Donaldson, J.S., Hughes, G.O., Midgley, G.F., Raimondo, D.C., Rebelo, A.G., Rouget, M. and Thuiller, W., 2005: Potential impacts of future land use and climate change on the Red List status of the Proteaceae in the Cape Floristic Region, South Africa. *Global Change Biology*, **11**(9): 1452-1468.
- Börjeson, L., Höjer, M., Dreborg, K.-H., Ekvall, T. and Finnveden, G., 2006: Scenario types and techniques: towards a user's guide. *Futures*, **38**(7): 723-739.
- Borrini-Feyerabend, G., Pimbert, M., Farvar, M.T., Kothari, A. and Renard, Y., 2004: *Sharing Power: Learning by doing in co-management of natural resources throughout the world*. Cenesta, Tehran, IIED and IUCN/CEESP/ CMWG.
- Brodie, J.E., Kroon, F.J., Schaffelke, B., Wolanski, E.C., Lewis, S.E., Devlin, M.J., Bohnet, I.C., Bainbridge, Z.T., Waterhouse, J. and Davis, A.M., 2012: Terrestrial pollutant runoff to the Great Barrier Reef: An update of issues, priorities and management responses. *Marine Pollution Bulletin*, **65**(4-9): 81-100.
- Bunnefeld, N., Hoshino, E. and Milner-gulland, E.J., 2011: Management strategy evaluation: a powerful tool for conservation? *Trends in Ecology and Evolution*, **26**(9): 441-447.
- Burgman, M., 2005: *Risks and Decisions for Conservation and Environmental Management*. Cambridge, Cambridge University Press.
- Butterworth, D.S., 2007: Why a management procedure approach? Some positives and negatives. *ICES Journal of Marine Science*, **64**(4): 613-617.
- Carmichael, J., Tansey, J. and Robinson, J., 2004: An integrated assessment modeling tool. *Global Environmental Change*, **14**(2): 171-183.
- Carpenter, S.R., Bennett, E.M. and Peterson, G.D., 2006: Scenarios for ecosystem services: an overview. *Ecology and Society*, **11**(1): 29.
- Carroll, C., Dunk, J.R. and Moilanen, A., 2010: Optimizing resiliency of reserve networks to climate change: multispecies conservation planning in the Pacific Northwest, USA. *Global Change Biology*, **16**(3): 891-904.
- Chankong, V. and Haimes, Y.Y., 1983: *Multiobjective decision making: theory and methodology*. New York, USA, North Holland.
- Chankong, V. and Haimes, Y.Y., 2008: *Multiobjective Decision Making: Theory and Methodology*. New York, USA, Dover Publ Inc.
- Chermack, T.J., 2011: *Scenario Planning in Organizations: How to Create, Use, and Assess Scenarios*. San Francisco, USA, Berrett-Koehler Publishers, Inc.
- CMP, 2011: Charter Declaration of the Conservation Measures Partnership (CMP).
- CMP, 2013: Open Standards for the Practice of Conservation.
- Cook, C.N., Inayatullah, S., Burgman, M.A., Sutherland, W.J. and Wintle, B.A., 2014: Strategic foresight: how planning for the unpredictable can improve environmental decision-making. *Trends in Ecology & Evolution*, **29**(9): 531-541.
- Crabbé, A. and Leroy, P., 2008: *The handbook of environmental policy evaluation*. London, England, Earthscan.
- De Marchi, B. and Ravetz, J.R., 2001: Participatory Approaches to Environmental Policy. Cambridge Research for the Environmen, Policy Research Brief, Cambridge, England.
- de Moor, C.L., Butterworth, D.S. and De Oliveira, J.A.A., 2011: Is the management procedure approach equipped to handle short-lived pelagic species with their boom and bust dynamics? The case of the South African fishery for sardine and anchovy. *ICES Journal of Marine Science*, **68**(10): 2075-2085.
- De Oliveira, J.A.A. and Butterworth, D.S., 2004: Developing and refining a joint management procedure for the multispecies South African pelagic fishery. *ICES Journal of Marine Science*, **61**(8): 1432-1442.
- Deat, 2005: National Biodiversity Strategy and Action Plan (NBSAP). South Africa.

- Dietz, L.A., Brown, M. and Swaminathan, V., 2010: Increasing the Impact of Conservation Projects. *American Journal of Primatology*, **72**: 425-440.
- Directive, S.E.A., 2001: Directive 2001/42/EC of the European Parliament and of the Council of 27 June 2001 on the assessment of the effects of certain plans and programmes on the environment. *European Parliament and of the Council*, **197**(21/07): 30-37.
- Drechsler, M., Frank, K., Hanski, I., O'Hara, R.B. and Wissel, C., 2003: Ranking Metapopulation Extinction Risk: From Patterns in Data to Conservation Management Decisions. *Ecological Applications*, **13**(4): 990-998.
- Dréo, J., Petrowski, A., Siarry, P. and Taillard, E., 2006: *Metaheuristics for Hard Optimization: Methods and Case Studies*. New York, USA, Springer.
- Drescher, M., Perera, A.H., Johnson, C.J., Buse, L.J., Drew, C.A. and Burgman, M.A., 2013: Toward rigorous use of expert knowledge in ecological research. *Ecosphere*, **4**(7): art83.
- Driscoll, D.A., Bode, M., Bradstock, R.A., Keith, D.A., Penman, T.D. and Price, O.F., 2015: Resolving future fire management conflicts using multicriteria decision making. *Conservation Biology*, **In Press**: 10 pages-10 pages.
- Driver, A., Sink, K.J., Nel, J.N., Holness, S., Van Niekerk, L., Daniels, F., Jonas, Z., Majiedt, P.A., Harris, L. and Maze, K., 2012: National Biodiversity Assessment 2011: An assessment of South Africa's biodiversity and ecosystems. Synthesis Report. 9781919976723, Pretoria.
- Du, J., Yang, Y., Xu, L. and Zhang, S., 2012: Research on the alternatives in a strategic environmental assessment based on the extension theory. *Environmental Monitoring and Assessment*, **184**(9): 5807-5819.
- Dusik, J. and Xie, J., 2009: Strategic environmental assessment in east and southeast Asia: a progress review and comparison of country systems and cases. The World Bank, Sustainable development - East Asia and Pacific Region discussion papers., Washington DC.
- Edwards, C.T.T., Bunnefeld, N., Balme, G.A. and Milner-gulland, E.J., 2014: Data-poor management of African lion hunting using a relative index of abundance. *Proceedings of the National Academy of Sciences (PNAS)*, **111**(1): 539-543.
- EEA, 2009: Progress towards the European 2010 biodiversity target. European Environmental Agency 9789291679935, Copenhagen.
- European Commission, 2011: Our life insurance, our natural capital: an EU biodiversity strategy to 2020. Luxembourg.
- European Parliament, 2009: The Common Fisheries Policy - A Practical Guide. Brussels, Belgium.
- European Union, 2008: Marine Strategy Framework Directive 2008/56/EC. Brussels, Belgium.
- Failing, L., Gregory, R. and Harstone, M., 2007: Integrating science and local knowledge in environmental risk management: a decision-focused approach. *Ecological Economics*, **64**(1): 47-60.
- FAO, 1993: Guidelines for land-use planning. Rome, Italy.
- Ferrier, S., Watson, G., Pearce, J. and Drielsma, M., 2002: Extended statistical approaches to modelling spatial pattern in biodiversity in northeast New South Wales. I. Species-level modelling. *Biodiversity and Conservation*, **11**(12): 2275-2307.
- Figueira, J., Greco, S. and Ehrogott, M., 2005: *Multiple criteria decision analysis: State of the art surveys*. New York, USA, Springer.
- Fischer, G.W., 1995: Range Sensitivity of Attribute Weights in Multiattribute Value Models. *Organizational Behavior and Human Decision Processes*, **62**(3): 252-266.
- Fischer, T.B., 2007: *The Theory and Practice of Strategic Environmental Assessment*. London, England, Routledge.
- Fischer, T.B., 2010: *The Theory and Practice of Strategic Environmental Assessment: Towards a More Systematic Approach*. Routledge.
- Fischer, T.B. and Seaton, K., 2002: Strategic environmental assessment: effective planning instrument or lost concept? *Planning Practice and Research*, **17**(1): 31-44.
- Fischer, T.B. and Onyango, V., 2012: Strategic environmental assessment-related research projects and journal articles: an overview of the past 20 years. *Impact Assessment and Project Appraisal*, **30**(4): 253-263.
- Fisher, B., Turner, R.K. and Morling, P., 2009: Defining and classifying ecosystem services for decision making. *Ecological Economics*, **68**(3): 643-653.

- Fordham, D.A., Wigley, T.M.L. and Brook, B.W., 2011: Multi-model climate projections for biodiversity risk assessments. *Ecological Applications*, **21**(8): 3317-3331.
- Gibbons, P., Zammit, C., Youngentob, K., Possingham, H.P., Lindenmayer, D.B., Bekessy, S., Burgman, M., Colyvan, M., Considine, M. and Felton, A., 2008: Some practical suggestions for improving engagement between researchers and policy-makers in natural resource management. *Ecological Management & Restoration*, **9**(3): 182-186.
- Glasson, J., Therivel, R. and Chadwick, A., 2013: *Introduction to environmental impact assessment*. 4th ed., Routledge.
- Goodwin, P. and Wright, G., 2001: Enhancing strategy evaluation in scenario planning: a role for decision analysis. *Journal of Management Studies*, **38**(1): 1-16.
- Gordon, T.J. and Helmer, O., 1964: Report on a long-range forecasting study. Santa Monica, California.
- Gregory, R., Failing, L., Harstone, M., Long, G., McDaniels, T. and Ohlson, D., 2012: *Structured Decision Making: A Practical Guide to Environmental Management Choices*. West Sussex, UK, John Wiley & Sons, Ltd.
- Groves, C.R., Jensen, D.B., Valutis, L.L., Redford, K.H., Shaffer, M.L., Scott, J.M., Baumgartner, J.V., Higgins, J.V., Beck, M.W. and Anderson, M.G., 2002: Planning for Biodiversity Conservation: Putting Conservation Science into Practice. *Bioscience*, **52**(6): 499-512.
- Guisan, A. and Thuiller, W., 2005: Predicting species distribution: offering more than simple habitat models. *Ecology Letters*, **8**(9): 993-1009.
- Guisan, A., Tingley, R., Baumgartner, J.B., Naujokaitis Lewis, I., Sutcliffe, P.R., Tulloch, A.I.T., Regan, T.J., Brotons, L., McDonald Madden, E., Mantyka Pringle, C., Martin, T.G., Rhodes, J.R., Maggini, R., Setterfield, S.A., Elith, J., Schwartz, M.W., Wintle, B.A., Broennimann, O., Austin, M., Ferrier, S., Kearney, M.R., Possingham, H.P. and Buckley, Y.M., 2013: Predicting species distributions for conservation decisions. *Ecology Letters*, **16**(12): 1424-1435.
- Hajkovicz, S.A., McDonald, G.T. and Smith, P.N., 2000: An Evaluation of Multiple Objective Decision Support Weighting Techniques in Natural Resource Management. *Journal of Environmental Planning and Management*, **43**(4): 505-518.
- Hall, N.G., Hershey, J.C., Kessler, L.G. and Stotts, R.C., 1992: A Model for Making Project Funding Decisions at the National Cancer Institute. *Operations Research*, **40**(6): 1040-1052.
- Hammond, J.S., Keeney, R.L. and Raiffa, H., 1998: *Smart Choices: A Practical Guide to Making Better Decisions*. Watertown, Massachusetts, Harvard Business Review Press.
- Happe, K., Kellermann, K. and Balmann, A., 2006: Agent-based Analysis of Agricultural Policies: an Illustration of the Agricultural Policy Simulator AgriPoliS, its Adaptation and Behavior. *Ecology and Society*, **11**(1): 27 pages-27 pages.
- Hastie, R. and Dawes, R.M., 2010: *Rational Choice in an Uncertain World: The Psychology of Judgment and Decision Making*. Los Angeles, SAGE Publications, Inc.
- Hawke, A., 2009: *Independent Review of the Environment Protection and Biodiversity Conservation Act 1999*. Canberra, ACT, Final report to the Minister for the Environment, Heritage and the Arts, [http:// www.environment.gov.au/epbc/review/index.html](http://www.environment.gov.au/epbc/review/index.html).
- Hilborn, R., 1992: Can fisheries agencies learn from experience? *Fisheries*, **17**(4): 6-14.
- Holland, D.S., 2010: Management Strategy Evaluation and Management Procedure: Tools for Rebuilding and Sustaining Fisheries. FAO, Food, Agriculture and Fisheries Working Papers, Paris, France.
- Holling, C., 1978: *Adaptive environmental assessment and management*. London, UK, John Wiley & Sons Ltd.
- Howard, R.A., 2012: The Foundations of Decision Analysis Revisited. Edwards, W., Jr, R.F.M. and von Winterfeldt, D., eds., Cambridge, England, Cambridge University Press, 32-56.
- Howlett, M., Ramesh, M. and Perl, A., 2009: *Studying Public Policy: Policy Cycles and Policy Subsystems*. Third ed. Oxford, England, Oxford University Press.
- Hulse, D.W., Branscomb, A. and Payne, S.G., 2004: Envisioning Alternatives: Using Citizen Guidance to Map Future Land and Water Use. *Ecological Applications*, **14**(2): 325-341.
- ICEM, 2010: MRC Strategic Environmental Assessment of hydropower on the Mekong mainstream. International Centre for Environmental Management Hanoi, Viet Nam.

- Inayatullah, S., 2004: *The causal layered analysis (CLA) reader: Theory and case studies of an integrative and transformative methodology*. Taipei: Tamkang University Press.
- Ittersum, M.K.V., Ewert, F., Heckeley, T., Wery, J., Alkan, J., Andersen, E., Bezlepina, I., Brouwer, F., Donatelli, M., Flichman, G., Olsson, L., Rizzoli, A.E., Wal, T.V.D., Erik, J. and Wolf, J., 2008: Integrated assessment of agricultural systems – A component-based framework for the European Union (SEAMLESS). *Agricultural Systems*, **96**(1-3): 150-165.
- Jann, W. and Wegrich, K., 2007: Theories of the Policy Cycle. In *Handbook of Public Policy Analysis: Theory, Politics, and Methods*, Fischer, F., Miller, G.J. and Sidney, M.S., eds., Boca Raton, FL, CRC Press, Taylor & Francis Group, 43-62.
- Jax, K., Barton, D.N., Chan, K.M.A., Groot, R.D., Doyle, U., Eser, U., Görg, C., Gómez-baggethun, E., Griewald, Y., Haber, W., Haines-young, R., Heink, U., Jahn, T., Joosten, H., Kerschbaumer, L., Korn, H., Luck, G.W., Matzdorf, B., Muraca, B., Neßhöver, C., Norton, B., Ott, K., Potschin, M., Rauschmayer, F., Haaren, C.V. and Wichmann, S., 2013: Ecosystem services and ethics. *Ecological Economics*, **93**: 260-268.
- Jellinek, S., Rumpff, L., Driscoll, D.A., Parris, K.M. and Wintle, B.A., 2014: Modelling the benefits of habitat restoration in socio-ecological systems. *Biological Conservation*, **169**: 60-67.
- Jennings, S., 2004: The ecosystem approach to fishery management: a significant step towards sustainable use of the marine environment? Browman, H.I. and Stergiou, K.I., eds., Inter Research, 279-282.
- Jennings, S., 2005: Indicators to support an ecosystem approach to fisheries. *Fish and Fisheries*, **6**(3): 212-232.
- Johnson, F.A., Moore, C.T., Kendall, W.L., Dubovsky, J.A., David, F., Kelley, J.R. and Williams, B.K., 1997: Uncertainty and the Management of Mallard Harvests. *The Journal of Wildlife Management*, **61**(1): 202-216.
- Joppa, L. and Pfaff, A., 2010: Reassessing the forest impacts of protection: The challenge of nonrandom location and a corrective method. *Annals of the New York Academy of Sciences*, **1185**(Ecological Economics Reviews): 135-149.
- Joseph, L.N., Maloney, R.F. and Possingham, H.P., 2008: Optimal Allocation of Resources among Threatened Species: a Project Prioritization Protocol. *Conservation Biology*, **23**(2): 328-338.
- Kahneman, D. and Tversky, A., 2000: *Choices, Values, and Frames*. Cambridge, England, Cambridge University Press.
- Kaji, K., Saitoh, T., Uno, H., Matsuda, H. and Yamamura, K., 2010: Adaptive management of sika deer populations in Hokkaido, Japan: theory and practice. *Population ecology*, **52**(3): 373-387.
- Keeney, R.L., 1982: Feature Article Decision Analysis: An Overview. *Operations Research*, **30**(5): 803-838.
- Keeney, R.L., 2007: Developing Objectives and Attributes. In *Advances in Decision Analysis*, Edwards, W., Miles, R.F. and von Winterfeldt, D., eds., Cambridge, England, Cambridge University Press, 104-128.
- Keeney, R.L. and Raiffa, H., 1976: *Decisions with Multiple Objectives: Preferences and Value Trade-Offs*. New York, USA, Wiley & Sons, Inc.
- Kremen, C., Cameron, A., Moilanen, A., Phillips, S.J., Thomas, C.D., Beentje, H., Dransfield, J., Fisher, B.L., Glaw, F., Good, T.C., Harper, G.J., Hijmans, R.J., Lees, D.C., Louis, E., Nussbaum, R.A., Raxworthy, C.J., Razafimpahanana, A., Schatz, G.E., Vences, M., Vieites, D.R., Wright, P.C. and Zjhra, M.L., 2008: Aligning Conservation Priorities Across Taxa in Madagascar with High-Resolution Planning Tools. *Science*, **320**(5873): 222-226.
- Krichen, S. and Chaouachi, J., 2014: *Graph-related Optimization and Decision Support Systems Saoussen Krichen*. New Jersey, USA, John Wiley & Sons, Inc.
- Lamoreux, J., Chatwin, A., Foster, M., Kakoyannis, C., Vynne, C., Wolniakowski, K. and Gascon, C., 2014: Overcoming the funder 's dilemma. *Biological Conservation*, **175**: 74-81.
- Leadley, P., Pereira, H.M., Alkemade, R., Fernandez-Manjarrés, J.F., Proença, V., Scharlemann, J.P.W. and Walpole, M.J., 2010: Biodiversity Scenarios: Projections of 21st century change in biodiversity and associated ecosystem services. Secretariat of the Convention on Biological Diversity, Technical Series 50, Montreal.
- Leadley, P.W., Krug, C.B., Alkemade, R., Pereira, H.M., Sumaila, U.R., Walpole, M., Marques, A., Newbold, T., Teh, L.S.L., Van Kolck, J., Bellard, C., Januchowski-Hartley, S.R. and Mumby, P.J., 2014: Progress towards the Aichi Biodiversity Targets: An Assessment of biodiversity Trends, Policy Scenarios and Key Actions. Secretariat of the Convention on Biological Diversity, Technical Series 78, Montreal, Canada.
- Linstone, H.A., Turoff, M. and Helmer, O., 2002: *The Delphi Method Techniques and Applications*. Reading, Massachusetts, Addison-Wesley Educational Publishers Inc.

- Little, L.R., Thébaud, O., Boschetti, F., McDonald, A.D., Marriott, R., Wise, B. and Lenanton, R., 2011: An Evaluation of Management Strategies for Line Fishing in the Ningaloo Marine Park, Final Report for Ningaloo Reef Project 3.2.3 Biodiversity Assessment, Ecosystem Impacts of Human Usage and Management Strategy Evaluation. CSIRO, IIFET 2010 Montpellier Proceedings, Australia.
- Liu, Y., Guo, H., Zhang, Z., Wang, L. and Dai, Y., 2007: An Optimization Method Based on Scenario Analysis for Watershed Management Under Uncertainty. *Environmental Management*, **39**(5): 678-690.
- Ludwig, D., Mangel, M. and Haddad, B., 2001: Ecology, Conservation, and Public Policy. *Annual Review of Ecology and Systematics*, **32**(2001): 481-517.
- MA, 2005: *Ecosystems and Human Well-being: Scenarios, Volume 2*. Washington, DC, Island Press.
- Madu, C.N., Kuei, C.-H. and Madu, A.N., 1991: Setting Priorities for the IT Industry in Taiwan- A Delphi Study. *Long Range Planning*, **24**(5): 105-118.
- Maguire, L.A., 2004: What Can Decision Analysis Do for Invasive Species Management? *Risk Analysis*, **24**(4): 859-868.
- Maier, H.R., Ascough Ii, J.C., Wattenbach, M., Renschler, C.S., Labiosa, W.B. and Ravalico, J.K., 2008: Uncertainty in environmental decision-making: Issues, challenges and future directions. In *ENVIRONMENTAL MODELLING, SOFTWARE AND DECISION SUPPORT: STATE OF THE ART AND NEW PERSPECTIVES*, Voinov, A., Jakeman, A., Rizzoli, A. and Chen, S.H., eds., Amsterdam, Int. Environ. Modell. and Software Soc.
- Malczewski, J., Moreno-Sanchez, R., Bojorquez-Tapia, L.A. and Ongay-Delhumeau, E., 1997: Multicriteria group decision-making model for environmental conflict analysis in the Cape Region, Mexico. *Journal of Environmental Planning and management*, **40**(3): 349-374.
- Mapstone, B.D., Little, L.R., Punt, A.E., Davies, C.R., Smith, A.D.M., Pantus, F., McDonald, A.D., Williams, A.J. and Jones, A., 2008: Management strategy evaluation for line fishing in the Great Barrier Reef: balancing conservation and multi-sector fishery objectives. *Fisheries Research*, **94**(3): 315-329.
- Margoluis, R., Stem, C., Swaminathan, V., Brown, M., Johnson, A., Placci, G., Salafsky, N. and Tilders, I., 2013: Results Chains: a Tool for Conservation Action Design, Management, and Evaluation. *Ecology and Society*, **18**(3): 22-22.
- McDonald-Madden, E., Probert, W.J.M., Hauser, C.E., Runge, M.C., Possingham, H.P., Jones, M.E., Moore, J.L., Rout, T.M., Vesk, P.A. and Wintle, B.A., 2010: Active adaptive conservation of threatened species in the face of uncertainty. *Ecological Applications*, **20**(5): 1476-1489.
- McFadden, J.E., Hiller, T.L. and Tyre, A.J., 2011: Evaluating the Efficacy of Adaptive Management Approaches: Is There a Formula For Success? *Journal of Environmental Management*, **92**: 1354-1359.
- McInerny, G.J., Chen, M., Freeman, R., Gavaghan, D., Meyer, M., Rowland, F., Spiegelhalter, D.J., Stefaner, M., Tessarolo, G. and Hortal, J., 2014: Information visualisation for science and policy: engaging users and avoiding bias. *Trends in Ecology & Evolution*, **29**(3): 148-157.
- Mendoza, G.A. and Martins, H., 2006: Multi-criteria decision analysis in natural resource management: A critical review of methods and new modelling paradigms. *Forest Ecology and Management*, **230**(1-3): 1-22.
- Mermet, L., Billé, R. and Leroy, M., 2010: Concern-Focused Evaluation for Ambiguous and Conflicting Policies: An Approach From the Environmental Field. *American Journal of Evaluation*, **31**(2): 180-198.
- Meyer, B.C. and Grabaum, R., 2008: MULBO: Model framework for multicriteria landscape assessment and optimisation. A support system for spatial land use decisions. *Landscape Research*, **33**(2): 155-179.
- Minas, J.P., Hearne, J.W. and Handmer, J.W., 2012: A review of operations research methods applicable to wildfire management. *International Journal of Wildland Fire*, **21**(3): 189-196.
- Ministry of the Environment, 2003: Effective SEA system and case studies. Ministry of the Environment Government of Japan, Tokyo, Japan.
- Moffett, A. and Sarkar, S., 2006: Incorporating multiple criteria into the design of conservation area networks: a minireview with recommendations. *Diversity and Distributions*, **12**(2): 125-137.
- Moilanen, A., Franco, A.M.A., Early, R.I., Fox, R., Wintle, B. and Thomas, C.D., 2005: Prioritizing Multiple-Use Landscapes for Conservation: Methods for Large Multi-Species Planning Problems. *Biological Sciences*, **272**(1575): 1885-1891.
- Molitor, G.T.T., 2003: *The power to change the world: The art of forecasting*. Potomac, MD, Public Policy Forecasting.

- Moorcroft, H. and Mangolomara, S., 2012: Conservation planning in a cross-cultural context: the Wunambal Gaambera Healthy Country Project in the Kimberley, Western Australia. *Ecological Management and Restoration*, **13**(1): 16-25.
- Moore, J.L. and Runge, M.C., 2012: Combining Structured Decision Making and Value of Information Analyses to Identify Robust Management Strategies. *Conservation Biology*, **26**(5): 810-820.
- Mustajoki, J., Hämäläinen, R.P. and Marttunen, M., 2004: Participatory multicriteria decision analysis with Web-HIPRE: a case of lake regulation policy. *Environmental Modelling & Software*, **19**(6): 537-547.
- Nichols, J.D. and Williams, B.K., 2006: Monitoring for conservation. *Trends in Ecology & Evolution*, **21**(12): 668-673.
- Nichols, J.D., Runge, M.C., Johnson, F.A. and Williams, B.K., 2007: Adaptive harvest management of North American waterfowl populations: a brief history and future prospects. *Journal of Ornithology*, **148**(2): 343-349.
- Nordström, E.-M., Eriksson, L.O. and Öhman, K., 2010: Forest Policy and Economics Integrating multiple criteria decision analysis in participatory forest planning: Experience from a case study in northern Sweden. *Forest Policy and Economics*, **12**(8): 562-574.
- Nuno, A., Bunnefeld, N. and Milner-gulland, E.J., 2014: Managing social – ecological systems under uncertainty: implementation in the real world. *Ecology and Society*, **19**(2): 52-52.
- OECD, 2012: *Strategic Environmental Assessment in Development Practice: A Review of Recent Experience*. Paris, France, OECD Publishing.
- Palomo, I., Martín-López, B., López-Santiago, C. and Montes, C., 2011: Participatory scenario planning for protected areas management under the ecosystem services framework: the Doñana social-ecological system in southwestern Spain. *Ecology and Society*, **16**(1): 23.
- Patel, M., Kok, K. and Rothman, D.S., 2007: Participatory scenario construction in land use analysis: An insight into the experiences created by stakeholder involvement in the Northern Mediterranean. *Land Use Policy*, **24**(3): 546-561.
- Peer, G., Matsinos, Y.G., Johst, K., Franz, K.W., Turlure, C., Radchuk, V., Malinowska, A.H., Curtis, J.M.R., Naujokaitis-Lewis, I., Wintle, B.A. and Henle, K., 2013: A Protocol for Better Design, Application, and Communication of Population Viability Analyses. *Conservation Biology*, **27**(4): 644-656.
- Petersen, A.C., Janssen, P.H.M., van der Sluijs, J.P., Risbey, J.S., Ravetz, J.R., Wardekker, J.A. and Martinson Hughes, H., 2013: *Guidance for Uncertainty Assessment and Communication*, 2nd edition. PBL Netherlands Environmental Assessment Agency, Bilthoven.
- Peterson, G.D., Cumming, G.S. and Carpenter, S.R., 2003: Scenario Planning: a Tool for Conservation in an Uncertain World. *Conservation Biology*, **17**(2): 358-366.
- Piroddi, C., Teixeira, H., Lynam, C.P., Smith, C., Alvarez, M.C., Mazik, K., Andonegi, E., Churilova, T., Tedesco, L., Chifflet, M., Chust, G., Galparsoro, I., Carla, A., Kämäri, M., Kryvenko, O., Lassalle, G., Neville, S., Niquil, N., Papadopoulou, N., Rossberg, A.G., Suslin, V. and Uyarra, M.C., 2015: Using ecological models to assess ecosystem status in support of the European Marine Strategy Framework Directive. *Ecological Indicators*, **58**: 175-191.
- Plaganyi, E.E., Van Putten, I., Hutton, T., Deng, R.A., Dennis, D., Pascoe, S., Skewes, T. and Campbell, R.A., 2013: Integrating indigenous livelihood and lifestyle objectives in managing a natural resource. *Proceedings of The National Academy of Sciences*, **110**(9): 3639-3644.
- Plagányi, É.E., Rademeyer, R.A., Butterworth, D.S., Cunningham, C.L. and Johnston, S.J., 2007: Making management procedures operational - innovations implemented in South Africa. *ICES Journal of Marine Science*, **64**(4): 626-632.
- Possingham, H., Ball, I. and Andelman, S., 2000: Mathematical Methods for Identifying Representative Reserve Networks. In *Quantitative methods for Conservation Biology*, Ferson, S. and Burgman, M., eds., New York, Springer, 291-306.
- Pressey, R.L., Watts, M.E., Barrett, T.W. and Ridges, M.J., 2009: The C-plan conservation planning system: origins, applications, and possible futures. In *Spatial Conservation Prioritization: quantitative methods and computational tools*, Moilanen, A., Wilson, K.A. and Possingham, H.P., eds., Oxford, England, Oxford University Press, 211-234.
- Punt, A.E. and Donovan, G.P., 2007: Developing management procedures that are robust to uncertainty: lessons from the International Whaling Commission. *ICES Journal of Marine Science*, **64**(4): 603-612.

- Rademeyer, R.A., Plagányi, É.E. and Butterworth, D.S., 2007: Tips and tricks in designing management procedures. *ICES Journal of Marine Science*, **64**(4): 618-625.
- Raiffa, H., 1968: *Decision Analysis -Introductory lectures on choices under uncertainty*. Reading, Massachusetts, Addison-Wesley.
- Rauch, W., 1979: The Decision Delphi. *Technological Forecasting and Social Change*, **15**(3): 159-169.
- Redpath, S.M., Arroyo, B.E., Leckie, F.M., Bacon, P., Bayfield, N., Gutierrez, R.J. and Thirgood, S.J., 2004: Using decision modeling with stakeholders to reduce human–wildlife conflict: a raptor–grouse case study. *Conservation Biology*, **18**(2): 350-359.
- Regan, H.M., Colyvan, M. and Burgman, M.A., 2002: A taxonomy and treatment of uncertainty for ecology and conservation biology. *Ecological Applications*, **12**(2): 618-628.
- Regan, H.M., Ben-Haim, Y., Langford, B., Wilson, W.G., Lundberg, P., Andelman, S.J. and Burgman, M.A., 2005: Robust Decision-Making under Severe Uncertainty for Conservation Management. *Ecological Applications*, **15**(4): 1471-1477.
- Richards, S.A., Possingham, H.P. and Tizard, J., 1999: Optimal Fire Management for Maintaining Community Diversity. *Ecological Applications*, **9**(3): 880-892.
- Robinson, J., 2003: Future subjunctive: backcasting as social learning. *Futures*, **35**(8): 839-856.
- Rogers, S., Casini, M., Cury, P., Heath, M., Irigoien, X., Kuosa, H., Scheidat, M., Skov, H., Stergiou, K., Trenkel, V., Wikner, J. and Yunev, O., 2010: Marine Strategy Framework- Task Group 4 Report, Food webs. Publications Office of the European Union, 9789279156564, Brussels, Belgium.
- Rowland, E.L., Cross, M.S. and Hartmann, H., 2014: *Considering Multiple Futures: Scenario Planning To Address Uncertainty in Natural Resource Conservation*. Washington, DC, US Fish and Wildlife Service.
- Roy, B., 1973: How outranking relation helps multiple criteria decision making. In *Multiple Criteria Decision Making*, Cochrane, J.L. and Zeleny, M., eds., Columbia, SC, University of South-Caroline Press, 179-201.
- Runge, M.C., Converse, S.J. and Lyons, J.E., 2011a: Which uncertainty? Using expert elicitation and expected value of information to design an adaptive program. *Biological Conservation*, **144**(4): 1214-1223.
- Runge, M.C., Bean, E., Smith, D.R. and Kokos, S., 2011b: Non-Native Fish Control below Glen Canyon Dam — Report from a Structured Decision-Making Project. Reston, Virginia.
- Saaty, T.L., 1980: *The Analytic Hierarchy Process: Priority Setting , Resource Allocation*. New York, USA, McGraw-Hill.
- Sabatier, P.A. and Weible, C.M., 2014: *Theories of the Policy Process*. Third ed. Boulder, Colorado, Westview Press.
- Salafsky, N., Margoluis, R. and Redford, K.H., 2001: *Adaptive management: a tool for conservation practitioners*. Biodiversity Support Program Washington, DC.
- Sandker, M., Campbell, B.M., Nzooh, Z., Sunderland, T., Amougou, V., Defo, L. and Sayer, J., 2009: Exploring the effectiveness of integrated conservation and development interventions in a Central African forest landscape. *Biodiversity and Conservation*, **18**(11): 2875-2892.
- Santelmann, M.V., White, D., Freemark, K., Nassauer, J.I., Eilers, J.M., Vaché, K.B., Danielson, B.J., Corry, R.C., Clark, M.E., Polasky, S., Cruse, R.M., Sifneos, J., Rustigian, H., Coiner, C., Wu, J. and Debinski, D., 2004: Assessing alternative futures for agriculture in Iowa, U.S. A. *Landscape Ecology*, **19**(4): 357-374.
- SAPM, 2009: Madagascar Digital Conservation Atlas Report. Système des Aires Protégées de Madagascar (SAPM), Madagascar.
- Savage, L.J., 1954: *The foundations of statistics*. New York, USA, John Wiley & Sons, Inc.
- sCBD, 2001: *Global Biodiversity Outlook*. Montreal, Canada, Secretariat of the Convention on Biological Diversity.
- sCBD, 2005: *Handbook of the Convention on Biological Diversity Including its Cartagena Protocol on Biosafety - 3rd edition*. Montreal, Canada, Secretariat of the Convention on Biological Diversity.
- sCBD and Netherlands Commission for Environmental Assessment, 2006: Biodiversity in Impact Assessment, Background Document to CBD Decision VIII/28: Voluntary Guidelines on Biodiversity-Inclusive Impact Assessment. Secretariat of the Convention on Biological Diversity, Technical Series No. 26 9042118113, Montreal, Canada.
- sCBD and PBL, 2007: Cross-roads of Life on Earth — Exploring means to meet the 2010 Biodiversity Target. Solutionoriented scenarios for Global Biodiversity Outlook 2. Secretariat of the Convention on Biological Diversity, PBL Netherlands Environmental Assessment Agency, 929225071X, Montreal, Canada.

- Schoemaker, P.J.H., 1991: When and How to Use Scenario Planning: A Heuristic Approach with Illustration. *Journal of Forecasting*, **10**(6): 549-564.
- Schoemaker, P.J.H., 1993: Multiple scenario development: Its conceptual and behavioral foundation. *Strategic Management Journal*, **14**(3): 193-213.
- Schoemaker, P.J.H., 1995: Scenario Planning: A Tool for Strategic Thinking. *Sloan Management Review*, **36**(2): 25-40.
- Schoemaker, P.J.H., 2012: *Profiting from uncertainty: Strategies for succeeding no matter what the future brings*. New York, Simon and Schuster.
- Schwartz, M.W., Deiner, K., Forrester, T., Grof-tisza, P., Muir, M.J., Santos, M.J., Souza, L.E., Wilkerson, M.L. and Zylberberg, M., 2012: Perspectives on the Open Standards for the Practice of Conservation. *Biological Conservation*, **155**: 169-177.
- Schwartz, P., 1995: *The art of the long view: planning for the future in an uncertain world*. New York, USA, Currency Doubleday.
- Shea, K., Possingham, H.P., Murdoch, W.W. and Roush, R., 2002: Active Adaptive Management in Insect Pest and Weed Control: Intervention With a Plan for Learning. *Ecological Applications*, **12**(3): 927-936.
- Shearer, A.W., 2005: Approaching scenario-based studies: three perceptions about the future and considerations for landscape planning. *Environment and Planning B: Planning and Design*, **32**(1): 67-87.
- Sheate, W., Dagg, S., Richardson, J., Aschemann, R., Palerm, J. and Steen, U., 2001: SEA and integration of the environment into strategic decision-making. *CEC Contract No. B4-3040/99/136634/MAR/B4*, **3**(Case Studies).
- Shiferaw, B. and Holden, S., 1999: Soil erosion and smallholders' conservation decisions in the highlands of Ethiopia. *World development*, **27**(4): 739-752.
- Smith, T.D., 1994: *Scaling fisheries: the science of measuring the effects of fishing, 1855-1955*. Cambridge, England, Cambridge University Press.
- Steele, K., Carmel, Y., Cross, J. and Wilcox, C., 2009: Uses and Misuses of Multicriteria Decision Analysis (MCDA) in Environmental Decision Making. *Risk Analysis*, **29**(1): 26-33.
- Steinitz, C., Arias, H. and Bassett, S., 2003: *Alternative Futures for Changing Landscapes: The Upper San Pedro Basin in Arizona and Sonora*. Washington, DC, Island Press.
- Stirling, A. and Mayer, S., 1999: *Rethinking Risk: A Pilot Multi-Criteria Mapping of a Genetically Modified Crop in Agricultural Systems in the UK*. Brighton, England, SPRU, University of Sussex.
- Susskind, L., Camacho, A.E. and Schenk, T., 2012: A critical assessment of collaborative adaptive management in practice. *Journal of Applied Ecology*, **49**(1): 47-51.
- Sutherland, W.J. and Woodroof, H.J., 2009: The need for environmental horizon scanning. *Trends in Ecology & Evolution*, **24**(10): 523-527.
- TEBTEBBA, 2010: Towards an Alternative Development Paradigm: Indigenous Peoples' Self-Determined Development. Tebtebba Foundation, 9789719356684, Baguio City, Philippines.
- Therivel, R. and Walsh, F., 2006: The strategic environmental assessment directive in the UK: 1 year onwards. *Environmental Impact Assessment Review*, **26**(7): 663-675.
- Therivel, R. and Paridario, M.R., 2013: *The practice of strategic environmental assessment*. Routledge.
- TNC, 2009: Rising Waters: Helping Hudson River communities adapt to climate change scenario planning 2010 – 2030. Executive summary. New York, USA.
- U. S. Fish & Wildlife Service, 2007: Adaptive Harvest Management: 2007 Hunting Season. U.S. Dept. Interior, Washington, DC.
- UN, 2008: United Nations Declaration on the Rights of Indigenous Peoples. United Nations, New York, NY.
- UNEP, 2002: *Global Environment Outlook 3. Past Present and Future Perspectives*. London, United Nations Environmental Programme.
- van der Sluijs, J.P., Craye, M., Funtowicz, S., Kloprogge, P., Ravetz, J. and Risbey, J., 2005: Combining quantitative and qualitative measures of uncertainty in model-based environmental assessment: the NUSAP system. *Risk analysis*, **25**(2): 481-492.

- Vancly, J.K., 1994: *Modelling forest growth and yield : applications to mixed tropical forests*. Wallingford, UK, CAB International.
- von Neumann, J. and Morgenstern, O., 1944: *Theory of Games and Economic Behavior*. New Jersey, Princeton University Press.
- Wallace, S.W., 2000: Decision making under uncertainty: Is sensitivity analysis of any use? *Operations Research*, **48**(1): 20-25.
- Walters, C.J., 1986: *Adaptive management of renewable resources*. New York, New York., Collier Macmillan.
- Walters, C.J., 2007: Is Adaptive Management Helping to Solve Fisheries Problems? *Ambio*, **36**(4): 304-307.
- Walters, C.J. and Holling, C.S., 1990: Large-Scale Management Experiments and Learning by Doing. *Ecology*, **71**(6): 2060-2068.
- Walz, A., Lardelli, C., Behrendt, H., Grêt-Regamey, A., Lundström, C., Kytzia, S. and Bebi, P., 2007: Participatory scenario analysis for integrated regional modelling. *Landscape and Urban Planning*, **81**(1): 114-131.
- Wang, Y.-M., Yang, J.-B. and Xu, D.-L., 2006: Environmental impact assessment using the evidential reasoning approach. *European Journal of Operational Research*, **174**(3): 1885-1913.
- Wardekker, J.A., van der Sluijs, J.P., Janssen, P.H.M., Kloprogge, P. and Petersen, A.C., 2008: Uncertainty communication in environmental assessments: views from the Dutch science-policy interface. *Environmental science & policy*, **11**(7): 627-641.
- WCMC, 1992: *Global Biodiversity. Status of the Earth's Living Resources*. Cambridge, England, World Conservation Monitoring Centre.
- WCS Futures Group and BIO-ERA, 2007: *Futures of the Wild: A Project of the Wildlife Conservation Society Futures Group*. Wildlife Conservation Society, New York, USA.
- Wei, Y., Davidson, B., Chen, D. and White, R., 2009: Agriculture, Ecosystems and Environment Balancing the economic, social and environmental dimensions of agro-ecosystems: An integrated modeling approach. *Agriculture, Ecosystems and Environment*, **131**(3-4): 263-273.
- Westgate, M.J., Likens, G.E. and Lindenmayer, D.B., 2013: Adaptive management of biological systems: a review. *Biological Conservation*, **158**: 128-139.
- Whitehead, A., Kujala, H. and Wintle, B.A., 2015: Identifying conservation priorities and assessing impacts of proposed future development in the Perth and Peel regions of Western Australia. A report by the NERP Environmental Decisions Hub. The University of Melbourne,
- Winship, A.J., Farrell, M.R.O. and Mohr, M.S., 2013: Management strategy evaluation applied to the conservation of an endangered population subject to incidental take. *Biological Conservation*, **158**: 155-166.
- Wintle, B.A. and Lindenmayer, D.B., 2008: Adaptive risk management for certifiably sustainable forestry. *Forest Ecology and Management*, **256**(6): 1311-1319.
- Wintle, B.A., Runge, M.C. and Bekessy, S.A., 2010: Allocating monitoring effort in the face of unknown unknowns. *Ecology Letters*, **13**(11): 1325-1337.
- Wintle, B.A., Bekessy, S.A., Keith, D.A., Van Wilgen, B.W., Cabeza, M., Schröder, B., Carvalho, S.B., Falcucci, A., Maiorano, L., Regan, T.J., Rondinini, C., Boitani, L. and Possingham, H.P., 2011: Ecological-economic optimization of biodiversity conservation under climate change. *Nature Climate Change*, **1**(7): 355-359.
- YEPB and Ramboll Natura, 2009: *Core Training Material on Strategic Environmental Assessment: Version 2*. Yunnan Environmental Protection Bureau, Yunnan.
- Zurell, D., Jeltsch, F., Dormann, C.F. and Schröder, B., 2009: Static species distribution models in dynamically changing systems: how good can predictions really be? *Ecography*, **32**(5): 733-744.

Chapter 3 Building scenarios and models of drivers of biodiversity and ecosystem change

Coordinating Lead Authors:

Michael Obersteiner (Austria), Ramón Pichs-Madruga (Cuba)

Lead Authors:

Mohamed Tawfic Ahmed (Egypt), Xuefeng Cui (China), Philippe Cury (France), Samba Fall (Senegal), Klaus Kellner (South Africa), Peter Verburg (the Netherlands)

Contributing Author:

Matthew Cantele (USA)

Review Editors:

Jyothis Sathyapalan (India), Neil Burgess (Denmark)

Purpose of this chapter: Provides an overview of broad types of scenarios for addressing the various policy and decision-making contexts introduced in Chapter 2; and critically reviews major sources of scenarios of indirect drivers and approaches to modelling resulting changes in direct drivers that can, in turn, serve as inputs to modelling impacts on biodiversity and ecosystems (covered in Chapter 4).

Target audience: A broader, less technical audience for the overview of scenario types; but a more technical audience for the treatment of particular scenario and modelling approaches.

Key findings

Expert-based and participatory methodological approaches to scenario development represent different sets of tools with respective advantages and disadvantages (3.2.1). Expert-based approaches are ideal during assessments in which empirical data can provide a solution and formal modelling is necessary. Expert-based methodologies are also appropriate for developing scenarios and models of indirect drivers, particularly as the temporal and spatial scales as well as uncertainties increase. Participatory approaches are ideal when dialog among local stakeholders is key to successful assessment outcomes as well as when local and indigenous expertise can supplement scientific knowledge at the spatial scale under consideration. Local ecological knowledge is valuable when assessing drivers at local spatial scales as a complement to other expert-based methodologies, particularly within the context of assessment resource and time constraints.

Choice of the type of scenario - exploratory or intervention - is highly contingent on the policy-cycle decision-making context (3.2.2). Exploratory scenarios are most often utilised during the initial problem identification stages to allow for the projection of multiple possible futures as well as identification of relevant stakeholders and problem specificities. While also employed in direct driver scenarios (scenarios of drivers), exploratory scenarios are particularly pertinent to investigating scenarios of potential indirect drivers. Intervention scenarios and techniques such as back-casting for target-seeking scenarios are more useful in later stages of the policy cycle where there is a consensus on the desired goals and focus is on potential pathways to such goals. Ex-ante (policy screening) and ex-post (retrospective policy evaluation) assessments are mutually reinforcing and complementary approaches in the policy cycle, and scenarios are very useful tools supporting these assessments.

No single model of drivers of change in biodiversity and ecosystem services can capture all dynamics at a high level of detail (3.2.3). The coupling or integration of models has become an important tool to integrate different scales and dimensions. Treatment of the spatial and temporal scales at which drivers operate as well as their interactions is crucial for construction of consistent and comprehensive scenarios on biodiversity and ecosystem services. Complex models can coexist with and be complemented by more stylised and simplified models. Stylised models can be useful to identify simple tipping and reference points.

Indirect and direct drivers interact on various spatial, temporal, and sectoral scales, producing synergies and feedbacks that need to be taken into consideration. Failing to take into consideration such dynamics can potentially render scenario analysis incomplete, inconsistent, or inaccurate (3.3, 3.4). Prominent indirect drivers exhibit significant interlinkages among themselves as well as with direct drivers of biodiversity and ecosystem change. Due to the nature of sociocultural phenomena, certain indirect drivers and their interlinkages are particularly difficult to explicitly formally model, yet need to be represented in scenarios of indirect drivers (3.3). As with indirect drivers, direct drivers also display considerable interlinkages and feedbacks, with significant potential for cascading effects on biodiversity and ecosystems (3.4).

Existing scenarios can serve as useful points of departure but are not likely to be appropriate in terms of temporal, spatial, and sectoral scales and may not contain sufficiently detailed storylines to be useful for the construction of Intergovernmental Platform on Biodiversity and Ecosystem Services (IPBES) driver scenarios (3.5). Scenarios need to be specifically tailored to the context of the biodiversity and ecosystem services studies. In many cases the environmental scales (e.g., habitats, biomes) may be more relevant for IPBES driver scenarios than institutional scales (e.g., administrative, municipalities, provinces, countries). Existing scenarios can be useful for the information they contain, but typically provide limited insight if applied without proper adaptation to the decision context of a particular biodiversity and ecosystem study.

Key recommendations

IPBES is encouraged to adopt tailored driver scenario methodologies reflecting the requirements of a biodiversity and ecosystem services specific decision-making context (3.2). Participatory modelling approaches are ideal in situations where local stakeholder involvement and collective governance are key to developing planning pathways, while expert-based approaches are best utilised when formal modelling methods and more rigorous quantitative analyses are required. Exploratory scenarios are best utilised in the initial policy cycle phases to elucidate

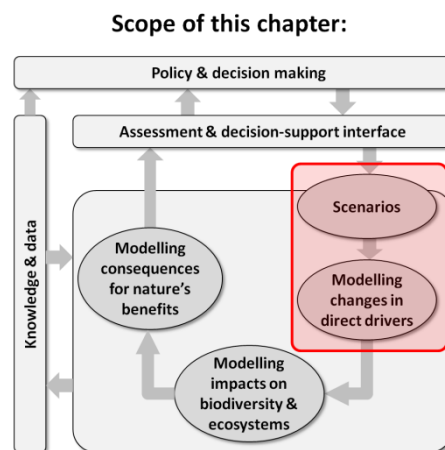

potential futures of indirect and direct drivers. Intervention scenarios, in particular target-seeking scenarios, are advantageous later in the policy cycle to formulate more concrete planning pathways for achieving goals associated with direct drivers. Indigenous and local knowledge are crucial for understanding the nature of the various drivers and the richness of their interactions in specific contexts.

IPBES is encouraged to invest in the development of and capacity-building for the modelling of drivers (3.3, 3.4). The IPBES task force on Knowledge, Information and Data and the follow-up activities of the scenarios and modelling deliverable are encouraged to facilitate the improvement of tools to integrate across scales. In order to broaden the capacity to create and use these tools, the task force on Capacity-Building would benefit from a specific focus on making these tools more freely available and on training programs. Spatially nested modelling approaches of indirect and direct drivers would be ideally employed to construct globally consistent national/local driver analysis. Driver scenarios need to address all relevant drivers of biodiversity and ecosystem services and connect short-term phenomena with long-term trends.

IPBES deliverables dealing with scenarios and models analysis, in particular author teams of the chapters on drivers of biodiversity and ecosystems change in IPBES regional assessments, are encouraged to carefully explore the interactions among indirect and direct drivers (3.3, 3.4). An improved understanding of potential driver synergies and feedbacks on the various spatial, temporal, and sectoral scales is essential to constructing biodiversity and ecosystem services specific scenarios and models. This analysis is particularly relevant for assessing the extent to which findings and conclusions on drivers at a specific scale may be relevant for extrapolation to other scales.

IPBES is encouraged to develop new scenarios of indirect and direct drivers that provide added value compared to existing global environmental assessment scenarios such as the Intergovernmental Panel on Climate Change (IPCC) Shared Socioeconomic Pathways (SSPs) / Representative Concentration Pathways (RCPs) and scenarios developed for the Millennium Ecosystem Assessment (MA) (3.5). While existing global scenarios can serve as reference points against which to benchmark specific IPBES driver scenarios, collaboration with other scenario development activities outside of IPBES (e.g., under the IPCC) is seen as highly beneficial. However, IPBES requires novel scenarios that address those direct and indirect drivers relevant to biodiversity and ecosystem services at spatial and temporal scales relevant to the underlying processes involved. Scenario development would benefit from reducing inconsistencies and fostering greater creativity within scenario storylines to capture the possible development directions of the multiple drivers underlying biodiversity and ecosystem services.

3.1 Introduction and chapter overview

Ecosystems and biodiversity have been influenced by natural drivers of change ever since the beginning of life on Earth. Until human activities began exerting considerable ecological impacts, ecosystems and biodiversity evolved under the influences of natural drivers such as changing climatic and lithospheric conditions. Drivers associated with human activities (anthropogenic drivers) have accelerated the rate of species extinction and significantly altered ecosystem properties to the extent that less than 25% of the remaining land surface remains ‘natural’ (Ellis, 2011). Some scientists have proposed naming this new geological epoch the Anthropocene where human activities on the Earth’s atmosphere, lithosphere, and biosphere in recent centuries have become the dominant drivers of change (Crutzen, 2006). There is now growing evidence that local-scale forcings (e.g., land use change) may lead to a threshold-induced state shift with significant implications for the Earth’s biosphere (Barnosky et al., 2012).

Chapter 3 focuses on approaches to building scenarios and models of drivers, and therefore provides a link between the policy and decision making context elaborated upon in Chapter 2 and the modelling of impacts of these drivers on biodiversity and ecosystems covered in Chapter 4 (see Figure 3.1) and, in turn, on nature’s benefits to people (including ecosystem services) and human well-being in Chapter 5. Chapter 3 builds on Chapter 2’s discussion of policy and decision-making needs relating to different phases of the policy cycle, by providing an overview of methodologies for building scenarios and models of indirect and direct drivers to address these needs. The chapter begins with an examination of methodological approaches including participatory and expert-based methods to developing scenarios followed by a summary of scenario types employed within the field of environmental assessments and decision-making. The uses and implications of several scenario approaches as well as ex-ante and ex-post assessments are explored (see 3.2.2.3). Modelling methods and the linkages between models are presented followed by detailed overviews of prominent scenarios and models of indirect and direct anthropogenic drivers. The chapter concludes with an examination of the research needs and gaps that need to be addressed as biodiversity and ecosystem services assessments progress.

3.1.1 Definition and classification of direct and indirect drivers

Scenarios of change in drivers are a basic component of models projecting biodiversity and ecosystem change.

Indirect drivers are drivers that operate diffusely by altering and influencing direct drivers as well as other indirect drivers (also referred to as ‘underlying causes’) (MA, 2005a; sCBD, 2014).

Understanding the role of indirect drivers is vital to understanding biodiversity and ecosystem change at the direct driver level. Indeed, indirect drivers frequently have primacy within the causal framework linking drivers to biodiversity and ecosystem change. Indirect drivers considered in this assessment include economic, demographic, sociocultural, governance and institutional, and technological influences.

Direct drivers (natural and anthropogenic) are drivers that unequivocally influence biodiversity and ecosystem processes (also referred to as ‘pressures’) (MA, 2005a; sCBD, 2014).

Over a long enough time frame, the impacts of direct drivers of change in biodiversity and ecosystem services nearly always influence, in turn, anthropogenic indirect drivers, thereby resulting in feedbacks between direct and indirect drivers (e.g., economic implications of climate change, overexploitation, and habitat modification on global fisheries (Sumaila et al., 2011)). Further, many direct drivers interact with other direct drivers, highlighting the complex interlinkages that need to be taken into consideration throughout assessment analyses. This chapter will specifically examine the following direct drivers: land-use change, climate change and pollution, natural resource use and exploitation, and invasive species. Indirect drivers also contribute to anthropogenic assets in the form of infrastructure, knowledge, technology, and financial assets. Anthropogenic assets result from the interaction between society and nature, and contribute to human well-being although their relative importance is context-specific.

3.1.2 Chapter overview

Drivers are not to be viewed as separate, static influences, but rather considered as dynamic factors interacting with and within each other. Indirect drivers frequently strongly interact, giving rise to complex emerging properties on various spatial and temporal scales.

As elaborated upon in Chapter 2, stages of the policy cycle range from agenda setting to policy implementation and eventual review. The policy cycle serves as a framework to facilitate effective decision making by taking into consideration a comprehensive analysis of the problem, followed by policy design, implementation, and finally evaluation of policy impacts. Accordingly, the specific policy and decision-making context of any given assessment of biodiversity and ecosystem services will to a large extent determine the point of departure for subsequent methodological approaches to building scenarios and models of drivers (see Figure 3.1). Participatory and expert-based methods and tools (Section 3.2.1) are key instruments for building driver scenarios of change in biodiversity and ecosystem services. Both approaches have their respective advantages, with participatory approaches facilitating multidisciplinary stakeholder participation and inclusion of indigenous knowledge while expert-based approaches allow for greater use of formal modelling techniques and scientific knowledge. Different types of approaches and models are described in this chapter, which can be used (separately or together) at different scales and to describe specific changes in biodiversity and ecosystems, as well as their linkages.

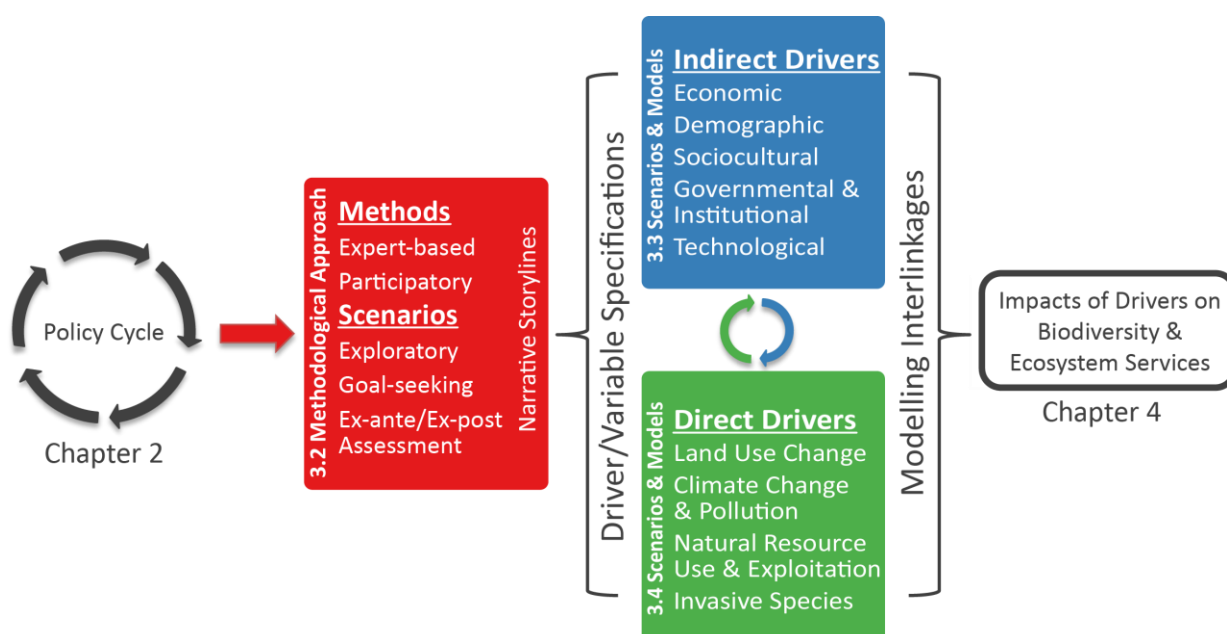

Figure 3.1: Chapter 3 overview

Scenario construction (Section 3.2.2) begins with development of qualitative storylines that are translated into driver scenarios. Modelling scenarios of indirect and direct drivers of biodiversity and ecosystem services (Section 3.3 and 3.4) is multi-faceted and in many cases multiple models are required to address multi-sectoral issues on different driver scales. The chapter then concludes with lessons learned and the way forward for future work on building scenarios and models of drivers of change in biodiversity and ecosystem services (Section 3.5).

3.2 Methodological approaches to scenario and model construction

The choice of method is crucial to the assessment of indirect and direct drivers. This choice depends strongly on the questions as well as the scope and scale of analysis. In this section the different methodological approaches for assessing indirect and direct drivers in relation to the context of use are outlined. Many methods start with either expert-based or participatory techniques to identify relevant indirect drivers and construct scenarios. Based on the scenario assumptions, different types of modelling tools are used to quantify the involvement of these indirect drivers and their impacts on the direct drivers.

3.2.1 Approaches

Expert-based approaches entail the use of expert opinion, knowledge (including scientific theory), or judgement to inform the various aspects of constructing scenarios and models of drivers. The term ‘expert’ implies an individual who has expertise or experience within a particular dimension through training, study, or involvement in practice (Raymond et al., 2010). Participatory methods and tools help define complex problems related to the governance of drivers impacting particular biodiversity and ecosystem services. They also provide a platform for views to be aired, perspectives broadened, and greater understanding of the policy issue under consideration. Including indigenous and local knowledge provides a more comprehensive reflection of prevailing conditions and other key inputs, and incorporates methods and approaches that capture holistic values that people place on nature while internalising principles and ethical values specific to their world views and realities (Illescas and Riqch’arina, 2007; Medina, 2014).

3.2.1.1 Expert-based approaches

Although all scenario construction implicitly involves some degree of expert opinion, formal expert-based scenario modelling entails identifying and eliciting information from multiple experts, either individually or in a group (Krueger et al., 2012). In order to determine whether expert opinion should be utilised, Kuhnert et al., (2010) provide the following steps: 1) articulation of research questions, 2) assessment of available empirical data and whether the data can provide a solution, and if it can, 3) verification that sufficient resources are available to carry out the elicitation. Expert knowledge can also be utilised in studies where requisite sampling over spatial and temporal scales is not possible due to financial and/or logistical constraints (Martin et al., 2005).

Expert-based approaches are particularly valuable for translating a perceptual model (i.e., qualitative understanding) into a formal model (i.e., mathematical representation) (Krueger et al., 2012). In addition to the contributions to formal modelling, expert opinion can enter models through informal vectors such as subjective choices and value-laden assumptions (see Box 3.1) as well as other biases consistent with the experts’ respective disciplinary training and background (Krueger et al., 2012).

Expert-based approaches are particularly susceptible to scientific uncertainties including subjective judgement as well as uncertainties associated with the parameterisation and weighting of variables.

Further, the use of heuristics and presence of cognitive biases associated with determining statistical probabilities can result in systematic biases throughout expert elicitations (Kynn, 2008).

Disadvantages of expert-based approaches often include limited knowledge of local biota and ecological processes (Stave et al., 2007) which can significantly increase the time and resources necessary to conduct environmental assessments. While identification of and disagreement among experts can pose obstacles to this method of scenario construction (as well as the cost and time consumption involved in eliciting information), scientists are increasingly aware of the advantages of the deliberate formal use of expert opinion to inform ecological models.

Experts can also be stakeholders – both experts and stakeholders vary in the degree to which they have expert knowledge as well as the extent to which they effectively have a stake in the issue under consideration (Krueger et al., 2012).

Experts can have significant institutional and financial interests, while scientific knowledge is not necessarily confined to traditional academic and research environments (Cross, 2003). The distinction between experts and stakeholders needs to therefore be undertaken carefully with the understanding that experiential knowledge will impact the type of uncertainty introduced into the model including individual biases. Here there are reliable techniques such as the Delphi Technique (see Box 3.1) that successfully reduce many uncertainties associated with expert-based elicitations.

Box 3.1 The Delphi Technique

Initially developed by the RAND Corporation in the 1950's, the Delphi Technique is a well-established method for eliciting the opinion of multiple experts, ideally 10 to 18 (Okoli and Pawlowski, 2004), which has been used to construct scenarios and support decisions (Rauch, 1979). This method is particularly valuable in data poor environments when translating qualitative responses into quantitative variables or subjective probabilities (Ouchi, 2004; MacMillan and Marshall, 2006) and is thus ideal for expert-based approaches to ecological modelling. The Delphi approach consists of consultations regarding the methodological approach, several rounds of independent and anonymous elicitation followed by feedback from experts leading to subsequent revisions, and resources permitting, incorporation of a workshop or meeting to address any remaining issues and crystallise final results. Under the guidance of an independent facilitator with knowledge in the field and experience in consensus building, the controlled environment of the Delphi method promotes independent thought by preventing direct confrontation between experts (Dalkey and Helmer, 1963). This method has the benefit of reducing undue influence by individual members as well as mitigating the degree to which some members may be persuaded to conform (i.e., group think). Here anonymity throughout the elicitation and revision cycles also serves to diminish other psychological biases inherent to group processes such as emergent group norms and gender related process strategies (e.g., Haidt, 2001; Hannagan and Larimer, 2010).

3.2.1.2 Participatory approaches

Participatory approaches to scenario development consist of involving a larger group of stakeholders through workshops or other formal meetings to share ideas and ultimately develop scenarios based on their collective knowledge.

This approach has the benefit of mobilizing local and indigenous expertise on scenarios as well as enabling participation and better informing local stakeholders (Patel et al., 2007; Palomo et al., 2011). Tools such as Fuzzy Set Theory assist in the coproduction of knowledge between experts and stakeholders through the quantification of key scenario and model parameters (Kok et al., 2015).

If properly conducted, participatory approaches help increase the effectiveness of environmental and biodiversity management (Palomo et al., 2011). Nonetheless, barriers to such approaches include limited understanding of relevant issues – particularly, the influence of exogenous drivers (those beyond the control of participants) and inter-scale (global, regional, national, local) interactions (MA, 2005b) – and considerable differences in opinion among participants as well as difficulty in translating qualitative data into quantitative inputs (Walz et al., 2007).

Among participatory approaches, the ‘agent-based participatory simulation’ method is a valuable way to investigate complex issues arising from natural resource management (Bousquet et al., 2002; Briot et al., 2007). Essentially, direct and indirect drivers of the depletion of biodiversity and ecosystem services are identified through a participatory exercise through a combination of role-playing games and multi-agent simulations. Relevant stakeholders are able to select the main indirect drivers and interactively construct numerous computer-based scenarios of collective governance for improved conservation of biodiversity and ecosystem services. The combined multi-agent simulations/role-playing games approach has proven to be an effective means of establishing sustainable and inclusive management schemes for protected areas which are under pressure. The key advantage of such an approach consists of stimulating a participatory consultation process which fosters a sound collective effort to identify relevant indirect and direct drivers of the transformational process and to formulate scenarios and pathways of potential conservation and restoration of biodiversity and ecosystem services.

Stakeholder participation has, for example, proved critical when identifying drivers of change and their importance for an ecosystem approach to fisheries. Based on the Food and Agriculture Organization (FAO) code of conduct for responsible fisheries (Attwood et al., 2005) and the Australian ecological sustainable framework (Fletcher et al., 2002), a series of locally adapted Ecological Risk Assessments have been developed in the Benguela Current region (i.e., South Africa, Namibia, and Angola) taking a participatory approach (Augustyn et al., 2014). This provides a transparent and structured process among stakeholders which helps to prioritise the issues and drivers that need to be considered (Nel et al., 2007). Additionally, participatory approaches are frequently employed simply to map out a range of views among participants.

3.2.2 Scenarios

Scenario construction is a valuable endeavour when attempting to construct possible futures in the context of uncertainties, particularly when ecological outcomes are highly contingent on indirect drivers such as economic growth and demography (Carpenter, 2002).

Thus, scenarios or ‘variants’ are employed to account for uncertainty within models of the future. In these cases, rather than attempting to predict from a specific set of values for driver variables onto a specific future, it is preferable to employ a variety of scenarios based on knowledge of a range of potential alternative futures (Peterson et al., 2003).

Exploratory scenario construction begins with the preparation of qualitative narrative storylines which provide the descriptive framework from which quantitative scenarios can be formulated. Such qualitative scenarios are particularly valuable as the temporal scale under examination increases and there are greater chances that exogenous influences may introduce unforeseen systemic change (e.g., technological shift) (Rounsevell and Metzger, 2010). The use of qualitative scenario storylines and subsequent parameterisation of key drivers has been well developed within the field of climate change research conducted by earlier IPCC assessments (Section 3.4.2). Here the specification of model-based scenario assumptions has evolved considerably over time in response to scientific advances in our understanding of climate change as well as the acknowledgement that socioeconomic drivers are an integral aspect of formulating potential futures (Abildtrup et al., 2006; Moss et al., 2010).

An extensive history of scenario building is beyond the scope of this paper – see (e.g., Amer *et al.*, 2013). Instead an overview of scenario use within the decision making context of the policy cycle, with a specific focus on exploratory and target-seeking scenarios as well as ex-ante and ex-post assessments is provided (Table 3.1). Within this context, choice of scenario and assessment type as well as the related methodological approach to scenario construction is highly contingent on the position within the policy cycle as well as the intended spatial scale.

Table 3.1

Combining Scenario Approaches and Policy Objectives

Approaches for using scenarios	Brief Summary	Relevance for Policy Making processes	Role of Indirect and Direct Drivers	Examples
EXPLORING alternative futures by using exploratory (descriptive) scenarios	Based on plausible alternative futures built on extrapolations of past trends and new assumptions.	Creates awareness of future policy challenges and agenda setting. Assumes the absence of explicit policy intervention .	Projections of indirect drivers and their effects on direct drivers.	IPCC SRES, 2000; Global Environment Outlooks (GEO)/UNEP; Millennium Ecosystem Assessment (MA), including from global to local applications
INTERVENTION: Using target-seeking scenarios (normative scenarios)	Starts with a prescriptive vision of the future and then works backward in time to visualise different pathways of achieving this future target	Policy Prescriptive Identifies the conditions necessary to achieve the desired target.	Identification of driver values consistent with the desired target.	IPCC Representative Concentration Pathways (RCPs) (Van Vuuren et al., 2011). VOLANTE European VISIONS on sustainable land use (Pedroli et al., 2015).
INTERVENTION: Policy screening using ex-ante assessment	Depicts the future effects of environmental policies	Policy Screening and impact assessment of alternative policy options before implementation.	Driver projections are used as reference for policy options.	The Strategic Environmental Assessment of the European Union (European Commission, 2001). Assessment of biofuel policies on direct and indirect land use change (e.g., Moser and Mußhoff, 2015)
POLICY EVALUATION using ex-post assessment	Looks backward to analyse the gap between environmental policy objectives and actual policy results, after using counterfactual scenarios	Reactive Policy Assessment Post hoc evaluation of policy effectiveness.	Identification of drivers explaining discrepancies of outputs	For assessing forest loss within and outside protected areas (monitoring the success of protected areas) {Joppa, 2010 #2033}.

3.2.2.1 Exploratory scenarios

Exploratory scenarios (also known as ‘descriptive scenarios’) typically have both strong qualitative and quantitative components and are often combined with participatory approaches involving local and regional level stakeholders (Kok et al., 2011). Exploratory scenarios frequently employ a co-evolutionary approach through the use of matrices where the projection of divergent futures is based on changes in the indirect and direct driver assumptions.

The relative benefits of exploratory scenarios include flexibility to construct storylines (conducive to greater creativity), coverage over a wide range of outcomes, and their application to problem areas where specific policy responses have yet to be formulated or the nature of the problem remains unclear (Van Vuuren et al., 2012a).

Exploratory scenarios are thus particularly relevant in the agenda-setting stage of the policy cycle where the scale, relevant stakeholders, and problem specificities are first addressed as the problem is brought to the public (see Figure

3.2) (Stone et al., 2001). Exploratory scenarios can illuminate discourse over the specific problems society will address given limited resources by illustrating various potential futures departing from the current point in time.

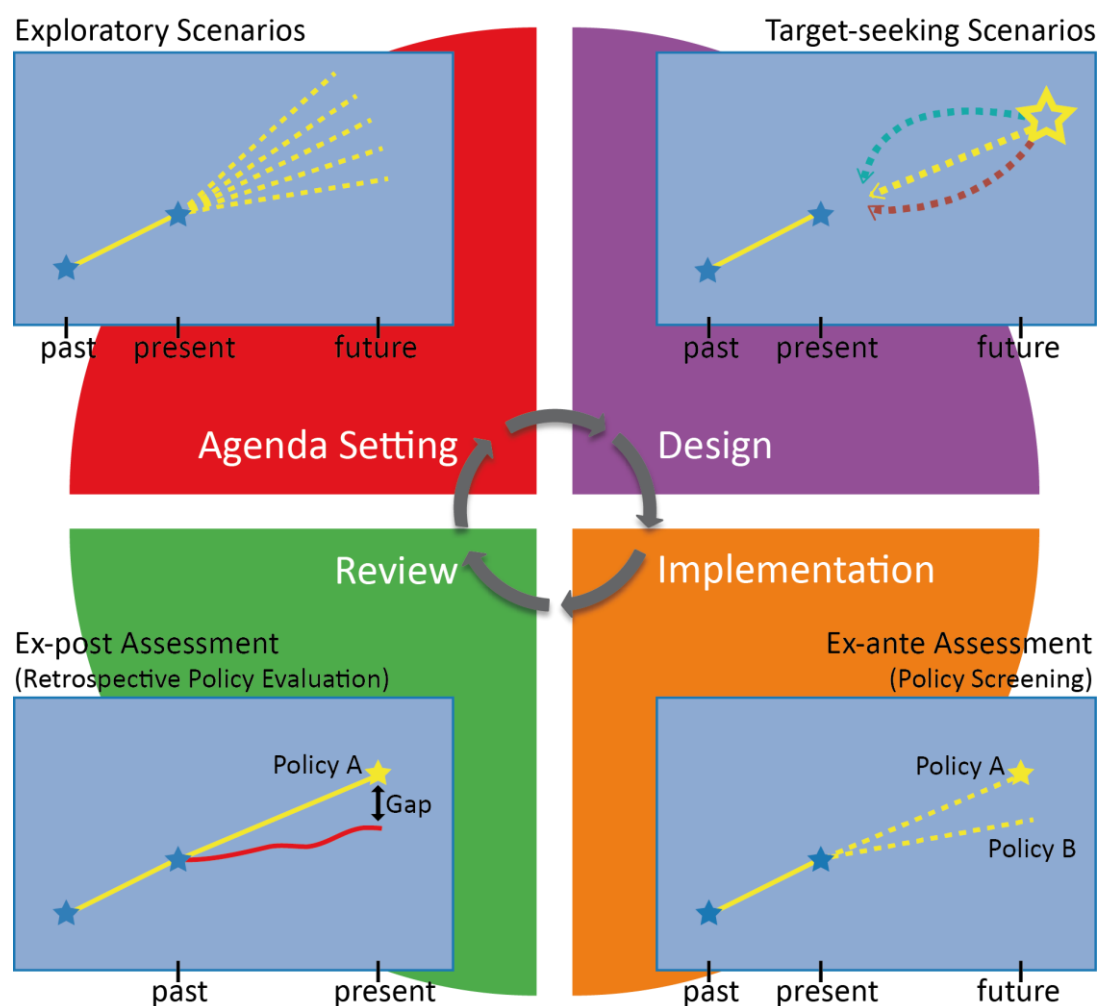

Figure 3.2: Scenario Approach within the Policy Cycle Context

Exploratory scenario approaches (see Box 3.2) have been utilised for climate change projections and were used in the IPCC assessments. This process started from estimating greenhouse gas emissions as the major driver for climate forcing, leading to the Special Report on Emissions Scenarios (SRES) and the latest RCPs. These scenarios were initially applied at a global scale with regional scale scenarios typically constructed through downscaling [Downscaling refers to the transformation of information from coarser to finer spatial scales through statistical modelling or spatially nested linkage of structural models].

Exploratory scenarios describe the future according to known processes of change or as extrapolations of past trends (IPCC, 2001).

In the absence of policy change, ‘business-as-usual’ or baseline scenarios represent a future with no major interventions or paradigm shifts in the functioning of a system.

However, the term ‘business-as-usual’ may be misleading in the policy-making process because exploratory scenarios can also describe futures that bifurcate at some point (e.g., adoption or rejection of a new technology) or that make some assumptions about the functioning of a system. Exploratory scenarios are common in environmental studies because they require less speculation about the future and tend to be more ‘value free’ compared to target-seeking or normative scenarios (Alcamo and Ribeiro, 2001). Further, researchers and stakeholders may be more comfortable with the forward progression of time in exploratory scenarios than with the backward-looking perspective adopted in target-seeking scenarios.

Box 3.2: Examples of explanatory scenarios narratives for coral reef ecosystems in the Caribbean**Main steps for building exploratory scenarios:**

- 1) Identification of research areas (regarding potential changes in biodiversity and ecosystems areas): globally, regionally, nationally, or locally (e.g., coral reef ecosystems in the Caribbean)
- 2) Identification of potential changes in biodiversity and ecosystems (e.g., increasing coral bleaching and mortality)
- 3) Identification of main drivers of change (direct and/or indirect drivers): e.g., a) climate change (ocean acidification, higher temperatures...); b) unsustainable socioeconomic activities (tourism, fishing,...)
- 4) Selection of scenario axes and scenario logic (This example includes two axes to simplify the illustration for didactic purposes. In practice, several key stressors can generate pressures on biodiversity and ecosystems in a specific area):
 - Climate change trends
 - Socioeconomic stressors in the Caribbean, particularly regarding unsustainable activities in coastal areas and oceans
- 5) Building preliminary scenarios:

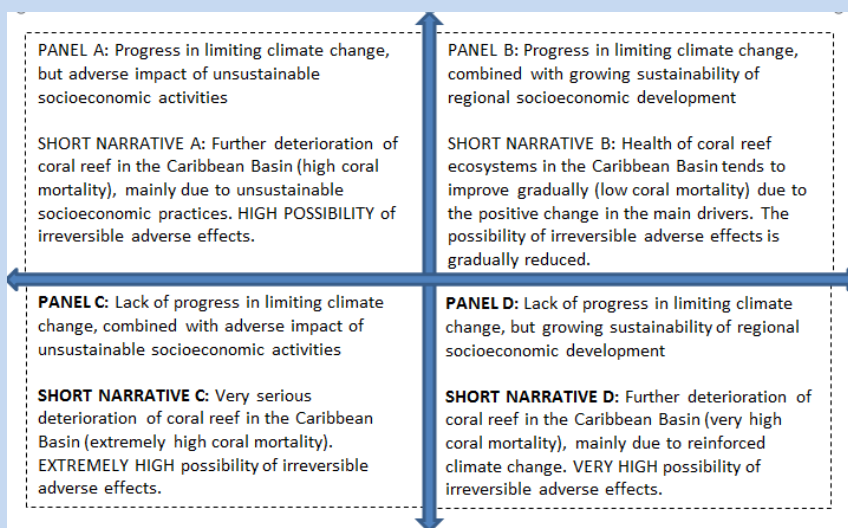
**3.2.2.2 Target-seeking scenarios**

Policy design, or formulation, is the stage in which the descriptive is transformed into the prescriptive according to the desired normative approach (Loorbach, 2010). Here the will to address a recognised problem is translated into a viable policy formulation with clearly defined objectives. In order for successful policies to be designed, policy options must be feasible in terms of economic and political resources as well as meet the needs of both the underlying science and interested stakeholders (Lemos and Morehouse, 2005; Jann and Wegrich, 2007). Employing normative pathway analyses such as backcasting approaches at this stage of the policy cycle allows for the identification of multiple potential pathways to a desired future vision. Target-seeking scenarios (also known as ‘normative scenarios’) constitute one sub-class of the more general class of intervention scenarios (also known as ‘policy scenarios’) introduced in Chapter 1.

Target-seeking scenarios are a valuable tool for examining the viability and effectiveness of alternative pathways to a desired outcome, particularly when used in conjunction with appropriate decision-support protocols and tools, such as those described in Chapter 2.

Target-seeking scenarios start with the definition of a clear objective or a set of objectives that can either be specified in terms of achievable targets (e.g., in terms of the extent of natural habitats remaining, or of food production self-sufficiency) or as an objective function to be optimised (e.g., minimal biodiversity loss).

Together with these goals and objective functions, a set of constraints is defined (e.g., excluding areas for conversion) to ensure realistically feasible outcomes. Back-casting (see Chapter 2) is particularly valuable when there is a great deal of uncertainty regarding future developments and the most likely future is not necessarily the most desirable (Robinson, 2003). Intervention scenarios typically encompass both the design and implementation phases (see Figure 3.2). Within this assessment, however, target-seeking scenarios and the subsequent ex-ante assessments (Section 3.2.2.3) are distinguished to highlight their relative contributions to weighing the relative desirability of different pathways.

Box 3.3: Example of target-seeking scenarios: Zonation tools (Moilanen et al., 2009) for protected area allocation under Aichi biodiversity target

According to the Aichi biodiversity target 11 adopted by the Convention on Biological Diversity, the protected area network should be expanded to at least 17% of the terrestrial world by 2020. There is considerable risk of ineffective outcomes due to land-use change and uncoordinated actions between countries. Recent research that used zonation tools to identify optimal location of protected areas for biodiversity conservation shows that with a coordinated global protected area network expansion to 17% of terrestrial land, average protection of species ranges and ecoregions could triple (Pouzols et al., 2014). If projected land-use change by 2040 takes place, it becomes infeasible to reach the currently possible protection levels, and over 1,000 threatened species would lose more than 50% of their present effective ranges worldwide. In addition, a major efficiency gap is found between national and global conservation priorities. Strong evidence is shown that further biodiversity loss is unavoidable unless international action is quickly taken to balance land-use and biodiversity conservation.

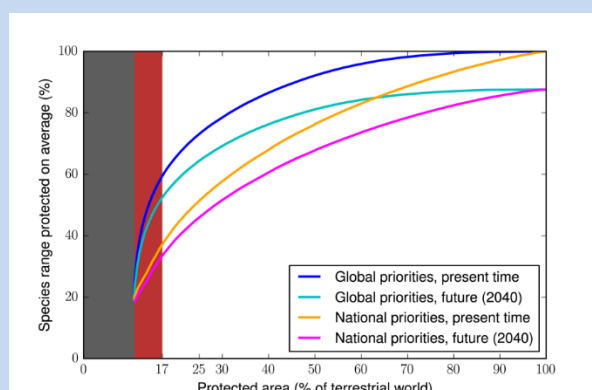

Figure Box 3.3: The relation between the protected area and the maximum attainable protection of species under conditions of optimal spatial allocation of protected areas. Under global priorities the allocation is made globally optimised while under national priorities the optimisation is based on a country-by-country basis. Future conditions refer to conditions under projected land use change which constrains the spatial allocation of protected areas (adapted from Pouzols et al., 2014)

3.2.2.3 Ex-ante/ex-post assessment

Ex-ante and ex-post assessments of environmental policies are tools in the policy making process. Ex-ante assessment is a proactive approach, oriented to identify and address potential effects of environmental policies. Many of the decision-support protocols and tools described in Chapter 2 provide a structured means of undertaking ex-ante assessments. This form of assessment typically makes strong use of a second sub-class of intervention scenarios (introduced in Chapter 1).

Ex-ante assessments use policy-screening scenarios to forecast the effects of alternative policy or management options (interventions) on environmental outcomes.

Environmental Impact Assessment (introduced in Chapter 2) is a widely used tool within this perspective. Ex-ante assessment usually starts in the very early stages of a policy formulation and design. Thus, it may contribute to social acceptance of policies by anticipating and addressing conflicting objectives and adverse effects. This assessment, when properly organised, may include expert considerations and consultations to relevant stakeholders such as government authorities, community representatives, Non-Governmental Organizations (NGOs), and the general public. This assessment perspective is embodied, for instance, in the Strategic Environmental Assessment of the European Union (European Commission, 2001).

Other types of scenarios (e.g., target-seeking scenarios) can be used to complement and support ex-ante assessments. In some cases these assessments are carried out through multiple scenario comparisons, and this approach helps policy makers to compare the potential consequences of various scenario-based options (e.g., Helming et al., 2011). In the intervention design phase different alternative policy options or management strategies are often developed. While final decisions will be heavily influenced by the full political and societal context, scenarios and models can better inform such decisions by investigating the effectiveness and unintended consequences of proposed policy measures through ex-ante assessment (Helming et al., 2011). Policy-screening scenarios require a detailed specification of changes in drivers such as uptake of policy measures on human behaviour, often focusing on shorter, more policy-relevant time frames than other types of scenarios. Economic and sector-based models are especially dominant here as the economic consequences and cost-benefit assessment of the proposed changes in drivers are essential in decision making.

The policy review phase involves the ex-post reflective assessment of the extent to which the policy implementation achieved the goals outlined in the initial stage of problem identification. In practice, evaluations are rarely consistent

with underlying theory which stipulates that multiple criteria and methods are used, formal policy goals are questioned, and stakeholders are actively involved throughout the process (Mickwitz, 2003; Huitema et al., 2011).

Ex-post assessments are the present evaluations of past efforts to achieve policy goals throughout all stages of the policy cycle and decision-making context.

Some key obstacles to the realisation of policy goals include instrument design oversight, inadequate monitoring, and an absence of effective enforcement mechanisms (Haug et al., 2010). Further, due to the inherent complexity of the environment-policy nexus, enactment of environmental policies may result in impacts that run counter to the original goals or encourage counterproductive behaviour such as rebound effects (Faber and Frenken, 2009).

Ex-post assessments can be based on straightforward monitoring of variables of interest as well as comparing the achieved change or status with the original targets and anticipated impacts of the implemented measures. In many cases it is important to distinguish the effects of the implemented policy or management scheme from the autonomous developments (Hoffmann et al., 2015). Econometric models are used to evaluate the contribution of different conditions on the monitored data. For example, straightforward ex-post assessments may assess forest loss within and outside protected areas to monitor the success of protected areas. However, such straightforward evaluations may be biased by the different locations of protected and unprotected natural areas that heavily impact the risk of deforestation (Joppa and Pfaff, 2010). Under such conditions more sophisticated techniques for ex-post assessment need to be applied that are able to distinguish the influence of such confounding factors on the monitored impacts.

3.2.3 Models

Many typologies of modelling tools of indirect and direct drivers and their interactions are possible. Modelling tools can for example be categorised depending on their qualitative or quantitative nature, whether the underlying phenomenon can be represented by structural equations or driver processes are captured by data driven approaches, and if the model is of deterministic or stochastic nature. Such broad typologies can typically be further broken down into sub-categories. For example, among structural models a distinction is made again between simulation models and normative target-seeking models. Among the latter, classical economic models typically maximise a welfare function or minimise costs. If such models cover the entire economy they are referred to as general equilibrium models while partial equilibrium models cover only a specific sector in greater detail. Such economic models can be constructed for comparative static analysis to analyse the introduction of new drivers such as policy shocks or for dynamic assessments to analyse solution pathways.

3.2.3.1 Modelling methods

Traditionally, structural economic models simulate indirect and direct drivers in deterministic settings and the latest developments in these models allow for the assessment of very uncertain and stochastic phenomena such as the impact of climate change (Leclère et al., 2014) or agricultural production volatility on land-use change (Fuss et al., 2015). Short-term forecasts of drivers, most frequently economic drivers, are generated by non-structural models implying that the modelling tool finds patterns in the data itself and projects these into the future. Tools for the extrapolation of current trends include statistical and econometric methods and data mining tools such as artificial neural networks, rough and fuzzy set, and network theory approaches. These tools also allow for projections of an ensemble of variables which interact with each other such as vector autoregressive models.

Data driven models typically will not allow for a mechanistic understanding of how and why drivers interact. As a general rule, the short-term prediction skill of data driven approaches is superior to mechanistic structural models. However, for long-term analyses where biophysical boundaries of production systems need to be respected and for the analysis of structural adjustments of drivers due to policy changes, mechanistic models are more suitable.

Good modelling practice

Modelling of indirect and direct drivers of change in biodiversity and ecosystem services has so far been undertaken mainly in the domain of academic research and thus good modelling practice is defined through the peer review process.

Key driver scenarios such as long-term Gross Domestic Product (GDP) development are produced through more expert driven simple models and are not subject to stringent technical quality control measures; and therefore the credibility of such driver projections typically rests on the reputation of the expert team.

Currently there are less than a handful of institutions which issue long-term projections of GDP. None of these models consider feedbacks from resource constraints. More sectoral models of indirect drivers such as integrated assessment models or partial equilibrium models are typically very large and highly complex due to their fundamentally non-linear structures. It is next to impossible to review such model structures with reasonably limited resources; if operated by an individual, analyses generated by such models are typically judged on the behaviour of a few output variables of interest given a specific problem. Integrated assessment models are typically used at the stage of policy formulation and very few of these models are actually used for policy planning purposes where review procedures are more biting than academic peer review. Given the fact that there are fundamentally different purposes and subsequent

review procedures for different modelling tools, the production of consistent scenarios of long-term driver behaviour is currently more an art than a science. It is unlikely that there will be a major break-through in the science of long-term projections of indirect and direct drivers. Rather there is a tendency to increasingly introduce quality control measures through good practice guidance.

For example, good practice guidance for greenhouse gas accounting in the land-use sector has been established for over more than a decade, and this provides the basic accounting rules for subsequent projections. The modelling process of producing projections is subject to TCCCA principles for good modelling practice to establish forest management reference level (FMRL) scenarios. The TCCCA principles stand for transparency, completeness, consistency, comparability, and accuracy, with the final aim to allow a technical evaluation of forest management reference level by an independent reviewer panel organised by the United Nations Framework Convention on Climate Change (UNFCCC). The ultimate purpose of forest management reference levels are to trigger payment streams for additional climate mitigation efforts.

3.2.3.2 Linking multiple models

The development and quantification of scenarios of indirect drivers, and their impacts on direct drivers of change in biodiversity and ecosystem services, is multi-faceted. In many cases multiple models are required to operate at different spatial scales and/or cover various driver constellations. For example, modelling of habitat conversion may require the use of demographic, economic, and biophysical models to properly represent the development of the impact of different indirect drivers. For regional assessments, global scale assessment models are often required to account for the influence of distant drivers on the region of interest, while region specific models are used to add finer spatial detail to the simulations (Verburg et al., 2008).

No single model can capture all dynamics at a high level of detail and the coupling or integration of models has become a popular tool to integrate the different dimensions. However, the degree of coupling varies among studies and the choice of integrated modelling versus a loose-coupling of models depends on the specific requirements of the assessment as well as the system under consideration.

Loose coupling of specialised models carries the advantage that the specific strengths of each model are retained. An example of this tactic is the nested modelling approach used by Verburg et al., (2008). Here global economic models explore changes in world consumption and production in terms of the consequences for land use at the level of world regions. Detailed, spatially explicit land-use change models subsequently downscale calculated areas of land use to individual pixels in order to show the types and location of changes in land use and terrestrial habitats. Based on the resulting land-use change patterns, a new set of models is used to assess the consequences of land-use change for carbon sequestration (Schulp et al., 2008) and ecosystem services.

The disadvantage of loose coupling of models where only limited information is exchanged between the models (often in only one direction) is the lack of representation of feedbacks between the modelled components and the risk of inconsistencies in representation of the same phenomenon in the different models (e.g., a forest in one model can be defined differently in another model).

The approach of loose coupling has the risk of the propagation of error and uncertainty between the coupled models which is difficult to track and quantify (Verburg et al., 2013b).

At the other end of the spectrum, integrated assessment models have been developed that embed the different model representations of the system in a consistent manner. Often, such integrated assessments models are modular and the different modules are built based on simple representations of the system under consideration. Given the embedding in a single simulation environment, the inclusion of feedbacks and interactions between the different modules is allotted more attention and there is consistent representation of variables across the different modules (Verburg et al., 2015).

For regional scales, similar models have been developed that include the most important spatially-specific indirect and direct drivers while taking into account knowledge about region-specific interactions and data availability (Harrison et al., 2015). A disadvantage of this approach is the inherent complexity of the models and the strongly simplified representation of the individual model components. Increased complexity reduces the applicability and transparency of the models (Voinov and Shugart, 2013). Although presently these models tend to be used for a wide range of different questions, their model structures often inherit a focus on the specific questions that the models were developed for. Therefore, care needs to be taken regarding the range of their application.

The choice of integrated modelling versus a loose-coupling of models depends on the specific requirements of the assessment but also on the system studied. An integrated modelling approach is required when feedbacks between the system components or spatial scales studied are important to system outcomes. However, when dynamics in the individual components are dominating, the use of specialised models to capture such dynamics adequately is recommended. Also, should the study aim to identify leverage points in the dynamics of the indirect drivers, a loosely coupled model approach may have advantages for studying the different components of the system both separately and as part of the full system, allowing identification of the role of system interactions.

3.3 Scenarios and models of indirect drivers

Within complex ecological systems, the role of indirect drivers is an integral aspect of scenario development and subsequent analysis. Indirect drivers play a major role in influencing direct drivers of biodiversity and ecosystem change as well as strongly influencing other indirect drivers. Socioeconomic and demographic trends heavily influence consumption patterns with subsequent environmental implications (e.g., Seto and Kaufmann, 2003). In addition to interacting with socioeconomic and demographic drivers, technological innovation can lead to the adoption of cleaner and more sustainable energy production as well as indirectly contribute to environmental degradation through electronic and other waste as well as increased demand for the raw materials used in new technologies. While difficult to model, understanding the role of societal drivers such as culture and government is crucial to sustainable ecosystem management as these are strong drivers of value sets and decision-frameworks that affect behaviours.

The influence of indirect drivers on biodiversity and ecosystem change materialises to a large extent through the valuation of biodiversity and ecosystem services. Institutional setups, as well as environmental policies and governance frameworks are currently embedded in shaping valuation outcomes, with long-term effects for biodiversity conservation and equity of access to ecosystem services benefits (Gomez-Baggethun and Ruiz-Perez, 2011). Elaborated upon in subsequent sections, the relative levels of different types of uncertainty (defined in Chapter 1) and extent of current use of indirect drivers in scenarios and models varies from driver to driver (Table 3.2).

Table 3.2

Degree of uncertainty and utilization in scenarios and models by indirect driver

Drivers	Utilization in Scenarios and Models	Stochastic Uncertainty	Scientific Uncertainty	Linguistic Uncertainty
Economic	high	low	low	low
Demographic	high	low	low	low
Sociocultural	low	low	high	high
Governance and Institutions	medium	medium	medium	medium
Technological	high	high	high	low

3.3.1 Economic trends

Economic drivers and economic trends impact both social and environmental dimensions of sustainable development. Economic growth is the main global driver of resource consumption (Dietz et al., 2007). Consequently, these drivers have a growing effect on ecosystems and ecosystems functions (Gomez-Baggethun and Ruiz-Perez, 2011). According to the *Millennium Ecosystem Assessment* (MA, 2005c), global economic activity increased nearly sevenfold between 1950 and 2000 and is expected to grow again by a further three- to six-fold as measured by GDP by 2050. While technological and institutional innovation have increased resource use efficiency, growth in consumption has outstripped increases in efficiency (Raudsepp-Hearne et al., 2010).

Taking a historical perspective, past and prevailing patterns of production and consumption embodied in global economic trends have generated growing pressures on natural resources, the environment, and ecosystems functions. The World Wildlife Fund (WWF) Living Planet Report (McLellan et al., 2014) concludes that humanity's demand has exceeded the planet's biocapacity for more than 40 years, and the Ecological Footprint shows that 1.5 Earths would be required to meet the demands humanity makes on nature each year. This demand is further compounded by the influence of population trends (see 3.3.2) and technological change (see 3.3.5).

GDP is widely used as the sole socioeconomic measure. Alternatively, the Human Development Index adopts a wider approach taking into account quality of life, health, and education (see UNDP, 2014). Even the Human Development Index has considered the economic component (income) as a key factor in its calculations since 1990, when the publication of the annual United Nations Development Programme (UNDP) Human Development Report started (UNDP, 2014). Virtually all socioeconomic and environmental scenarios for this century (i.e., up to the year 2050 and beyond) include economic growth as a key driver. GDP scenarios are typically built on explicit storylines about the evolution of determinants of the economic system.

For example, the identification of possible elements of Shared Socioeconomic Pathways (SSPs) scenarios (O'Neill et al., 2014) consider the following scenario elements essential within the category of 'economic development': global and regional GDP, or trends in productivity; regional, national, and sub-national distribution of GDP, including economic catch-up by developing countries; sectoral structure of national economies, in particular the share of agriculture, and agricultural land productivity; share of population in extreme poverty; and nature of international

trade. More information on the SSPs including economic and demographic projections can be found at the SSP Database (<https://tntcat.iiasa.ac.at/SspDb>).

According to the IPCC Fifth Assessment Report (IPCC, 2014), economic and population growth continued to be the most important indirect drivers of CO₂ emissions. This assessment highlights that the contribution of population growth between 2000 and 2010 remained roughly identical to the previous three decades, while the contribution of economic growth has risen sharply.

Scenarios that assume rapid economic growth in the coming decades are mainly based on prioritising market goals and incentives under conventional market approaches, with adverse social and environmental implications, including negative impacts on biodiversity and ecosystems (e.g., Global Environmental Outlook 4 (GEO4) Market First, Rothman et al., 2007) (IIEP et al., 2009).

The linkages between economic drivers and technological development have also been explored in the context of building socioeconomic and environmental scenarios. In many cases, scenarios assuming rapid economic growth in a conventional market context are based on dynamic technological development. However, many multidimensional asymmetries characterise these processes.

3.3.2 Demographic trends

In concert with other indirect drivers, changes in population size as well as demographic variables such as population distribution and age structure exert significant anthropomorphic pressures on direct drivers of biodiversity and ecosystem change. Demographic pressures are intricately interlinked with consumption and environmental externalities, many of which exhibit nonlinear dynamics not regulated by market forces (Dasgupta and Ehrlich, 2013). In addition to greater demand for natural resources, growing populations require greater amounts of food, driving land-use and land-cover change through deforestation and conversion to agricultural land. Populations with high per capita consumption rates (of goods and services) generate high demand for natural resources, representing a potentially greater biodiversity and ecosystem services threat than population growth (see Section 3.3.3).

Urbanisation driven by growing populations and internal migration acts as an indirect driver of land-use change through linear infrastructures such as transportation networks as well as synergies with other forms of infrastructure development (Seiler, 2001).

Further, while the effect of urbanisation on local land-use change is a complex phenomenon contingent on a number of factors, outmigration to urban areas frequently results in greater mechanisation and agricultural intensification made possible by remittances and driven by higher urban consumption levels (Lambin and Meyfroidt, 2011).

The primary determinants of population growth and structure are fertility, mortality, and migration, with fluctuations among the former two characteristic of stages in the Demographic Transition Model (e.g., Caldwell et al., 2006). Regional and local variation exists where there is significant socioeconomic, governmental, and developmental heterogeneities, particularly between rural and urban areas of less developed countries. The most recent United Nations (UN) population projections (UN, 2015) utilise Bayesian hierarchical models and the cohort component method to formulate probabilistic forecasts of population growth, adding to the high/low/med scenarios of past UN projections (Gerland et al., 2014). Whereas the UN projects continued growth throughout this century, the International Institute of Applied Systems Analysis (IIASA) projects an 85% chance of global population stabilisation and relies more heavily on expert-based assumptions, utilising a multi-state cohort model to produce projections by age and sex, differentiated by education (Lutz et al., 2014). Here projections are formulated according to five Shared Socioeconomic Pathways and contingent assumptions for fertility, mortality, migration, and education.

While focus within the field of demography is on global and national level population projections, future research is increasingly taking into consideration subnational migration patterns and differential population trajectories according to socioeconomic heterogeneities. Such analyses will be of considerable importance for understanding the effect of population growth on biodiversity and ecosystem change at regional and local spatial scales. As one example, population age structure has been found to influence consumption patterns, with younger and older people consuming more than middle-aged cohorts (e.g., Erlandsen and Nymoén, 2008; Liddle and Lung, 2010). This illustrates the paramount importance of examining how people interact with their environment due to socioeconomic (3.3.1) and sociocultural (3.3.3) influences.

3.3.3 Society and culture

Culture in the form of the values, norms, and beliefs of a group of people can act as an indirect driver of ecosystem change by affecting environmentally relevant attitudes and behaviours. Chapter 5 provides an elaboration on the role of values (See also IPBES Deliverable 3d *on the conceptualization of multiple values*). The influence of societal and cultural values (and subsequent behaviour) on indirect and direct drivers of biodiversity and ecosystem change is acknowledged throughout existing literature (e.g., Milton, 2013).

The impact of sociocultural influences on drivers of biodiversity and ecosystem change is often not explicitly captured in formal modelling methods due to the difficulty of identifying and parameterising what are often complex and overlapping phenomena.

In this respect, within modelling applications the role of sociocultural heterogeneity is frequently overshadowed by more easily quantified socioeconomic metrics (e.g., GDP and education), prompting criticism that data-driven methodologies place an undue emphasis on measurable indicators while neglecting the role of sociocultural values and practices.

In addition to the challenge of identifying and measuring sociocultural drivers that capture the way in which people interact with their environment, understanding environmentally relevant attitudes and values is further complicated by the value-action gap (Blake, 1999; Kollmuss and Agyeman, 2002). Here there is a large body of quantitative research from the cognitive sciences highlighting the considerable disparity between knowledge, values, and actual behaviour, indicating that rationalist linear models do not fully capture the processes underpinning decision-making behaviour (e.g., Bechara et al., 1997; Haidt, 2001). Research into social networks reveals that behaviour is substantially shaped by the sociocultural context in which individuals are embedded (Christakis and Fowler, 2013). These dynamics also apply to pro-environmental behaviours with for example the use of block leaders to disperse information on conservation through community and social networks (Abrahamse and Steg, 2013). The growing field of social network analysis thus represents one statistically rigorous method of identifying the individuals who are the most influential in spreading information and values through their respective peer networks (i.e., high centrality individuals) (Burt et al., 2013).

Due in part to their highly interlinked and amorphous character, sociocultural values are greatly affected by other indirect drivers. For example, in India researchers have largely attributed low meat consumption to cultural and religious traditions which prohibit and discourage meat consumption, particularly beef (Godfray et al., 2010a). Although India is known as one of the world's most vegetarian friendly countries, a closer examination reveals a considerable amount of heterogeneity in India's diet and a trend toward the adoption of Western consumption patterns (Amarasinghe et al., 2007; Deaton and Drèze, 2009). Livestock production has a substantial negative impact on biodiversity through a number of direct drivers including meat production related habitat loss, indirect and direct greenhouse gas emissions, land degradation caused by excessive grazing, and nutrient pollution (Stehfest et al., 2009; Machovina et al., 2015). Due to the considerable environmental impact of meat heavy diets (Herrero et al., 2013), scenario analyses often include meat, vegetarian, and healthy diet variants (e.g., Stehfest et al., 2009; Wirseniuss et al., 2010).

3.3.4 Governance and institutions

Institutions play an important role in the management and exploitation of biodiversity and ecosystem services (Lowry et al., 2005; Abunge et al., 2013). Ill-informed and weak governance frequently leads to mismanagement of the commons (see Box 3.3) as well as the adoption of environmentally unsustainable policies (Laurance, 2004; UNEP, 2013). Effective institutional design and implementation is however crucial. Institutional drivers operate at various spatial scales from global (international) to local (subnational) and include the influence of policies that encourage a particular behaviour (e.g., agricultural subsidies) as well as the direct impact of enacting environmental legislation (e.g., designation of conservation areas). The concept of governance used by Gupta and Pahl-Wostl (2013) refers to the exercise of authority by different social actors through the development and implementation of explicit and implicit substantive and procedural rules to manage resources for the social good.

In many countries 'soft' factors such as weak governance and institutions, lack of cross-sectoral coordination, and illegal activity are cited as key indirect drivers of ecosystem change (Kissinger and Rees, 2010). Common governance challenges include confused goals, conflicts, and unrealistic attempts to scale up beyond institutional capacity. Where collective action and conflict resolution mechanisms break down, governance of ecosystem resources is compromised (Ostrom, 1990). Fragmented legal systems can lead to gaps and conflicts (Tejera and Klein, 2011, Pomeroy et al., 2010), while governance of large-scale ecosystems requires identification of the heterogeneous, multi-scale, and interlinked nature of these systems (Fidelman et al., 2012).

Institutions can promote ecosystem services exploitation. For instance, in Thailand, policies that promoted shrimp farming by absentee landlords led to the massive destruction of mangrove ecosystems and thereby exposure of coastal communities to catastrophic storm and tsunami events (Barbier et al., 2011). Alternatively, public policies can positively affect biodiversity and ecosystem services dynamics as exemplified by recovering fish stocks under the Common Fisheries Policies of the European Union (Fernandes and Cook, 2013). Here secure private-property rights are widely viewed to promote more efficient resource utilisation and property management than open access schemes, although there are many circumstances in which private-property rights do not guarantee resource conservation (Acheson, 2006) and most common property arrangements involve some degree of private-property management (Ostrom and Hess, 2007). Further, group size and makeup (e.g., gender) have important implications for sustainability in situations involving collective resource management (Poteete and Ostrom, 2004; Westermann et al., 2005).

Within impoverished environments, governmental and institutional norms condoning corruption can easily become entrenched, with significant consequences for the sustainable management of biodiversity and ecosystem services.

The failure to enforce rules (e.g., due to corruption or underfunding) as well as the absence of clear boundaries at the local level can lead to collective action problems (Gibson et al., 2005).

So called ‘paper parks’ are one example of where intended conservation measures lack the political willpower or enforcement capabilities necessary to carry them out (Wright et al., 2007). The problem of corruption is particularly pronounced when enforcement of rules regarding highly valued resources hinges on the ability of poorly paid government officials to resist bribes (Smith et al., 2003). Further, the sustained impacts of direct drivers such as natural disasters can result in governmental and institutional instability, highlighting potential feedbacks between indirect and direct drivers (see Box 3.4).

Box 3.4: Divergent environmental management histories in Haiti and the Dominican Republic

The effects of institutional and governmental policies on the environment is clear in the contrast observed between the Dominican Republic and Haiti. Despite geographical similarities, a long history of weak environmental governance coupled with colonial exploitation has led to ecosystem degradation and increased vulnerability to natural disasters in Haiti (Roc, 2008). In addition to biodiversity protection and preservation, forest conservation measures as well as planning and adaptation capacities are crucial aspects for reducing the impact of natural disasters on human life and development (Day, 2009). In contrast with Haiti, the Dominican Republic has largely mitigated such consequences through successful environmental management. Where Haiti’s forested territory has shrunk from approximately 85% in the 15th century to 2-4% today, forest cover in the Dominican Republic has rebounded from 12% in the 80s to 40% today due in large part to reforestation programs and enforcement of regulations. In Haiti, land degradation resulting from deforestation and unsustainable agricultural practices is a major direct driver of ecosystem change, with trade in charcoal providing a strong economic impetus. In contrast with the constitution of the Dominican Republic which prioritises sustainable environmental management, many of the relevant laws in Haiti date to the 19th century and enforcement of extant regulations is hampered by a lack of political will as well as technical and financial limitations.

International trade and financial policies and practices considerably influence biodiversity and ecosystems services. Trade liberalisation, for instance, may have positive impacts to the extent that it stimulates the more efficient use of resources on macro-scales and connects more regions to the world market. However, higher levels of foreign debt service, structural adjustment programs, and high dependency on primary sector exports are associated with a higher numbers of threatened mammals and birds because structural adjustment loans and large debt service burdens lead debtor nations to increase exports of agricultural goods and natural resources in order to generate currency for debt repayment (Shandra et al., 2010). Finally, conflicts undercut or destroy environmental, physical, human and social capital, diminishing available opportunities for sustainable development (UNEP, 2006).

The vital role of governance and institutions as drivers of biodiversity and ecosystems change was highlighted in the ALARM project with scenarios encompassing agricultural, chemical, energy, transport, technology, and trade sector policy variants (Spangenberg, 2007). The future application of the current ecosystem services approach will need to involve a more critical focus on environmental governance, transparency, and participation as well as a consideration of the great uncertainties prevailing at various spatial and temporal scales (Paavola and Hubacek, 2013).

A more thorough understanding of how biodiversity, ecosystems and ecosystems services are governed, and incorporation of this understanding into driver scenarios, will be crucial to ensuring improved biodiversity and ecosystem services management in the context of governance systems.

3.3.5 Technology

The rate of technological change is considered as an indirect driver of biodiversity and ecosystem services change because it affects the efficiency by which ecosystem services are produced or used (Alcamo et al., 2005). It is recognised that technological change can result in increased pressure on ecosystem services through increased resource demand as well as lead to unforeseen ecological risks. In comparison with anthropomorphic indirect drivers that are relatively constrained by biophysical limitations such as economic and demographic trends, technological innovation can potentially serve as a catalyst of paradigmatic shifts in production systems with considerable societal implications (e.g., Perez, 2004). Although technology can significantly increase the availability of some ecosystem services, and improve the efficiency of provision, management, and allocation of different ecosystem services, it cannot serve as a substitute for all ecosystem services (Carpenter et al., 2006).

The impact of technological innovation on biodiversity and ecosystem change is exerted through its influence on direct drivers as well as through interactions and synergies with other indirect drivers. With the exception of recent work (e.g., Dietrich et al., 2014), the role of technology trends in land-use change modelling applications is typically implemented exogenously due to the relative paucity of information on the relationship between research and development (R&D) and technological change. Such decoupling of the assumptions about technological change from model dynamics can result in an underestimation (or potentially over-estimation) of technological change that is most

problematic in long-term projections (Dietrich et al., 2014). As with economic and demographic drivers, scenarios of technological change are included within the SSPs.

Technologies associated with agriculture and other land uses (see Box 3.4) have a large impact on drivers of biodiversity and ecosystem change. The agricultural intensification of the ‘green’ revolution led to higher crop yields and lower food prices, to some extent mitigating the expansion of agricultural land (Evenson and Gollin, 2003) and resulting in a net decrease of greenhouse gas (GHG) emissions (Burney et al., 2010). However, while intensification may have represented an advantageous pathway from a land-use change and climate change perspective, excessive nitrogen and phosphorous use through fertilisers has led to substantial degradation of freshwater and marine habitats (Smith et al., 1999). Further, the shift from traditional crop varieties to industrial monocultures resulted in a loss of crop genetic diversity (FAO, 2010) as well as increased susceptibility to disease and pests (Zhu et al., 2000; Jump et al., 2009). Looking to the future, recent projections of global food demand foresee a doubling of crop production from 2005 to 2050 (Tilman et al., 2011), in large part due to a global dietary shift toward greater rates of meat consumption now taking place throughout the developing world (Delgado, 2003; Speedy, 2003; Thow and Hawkes, 2009).

Agricultural land expansion is estimated to be the direct driver for around 80% of deforestation worldwide and is the dominant cause of land-use change (Hosonuma et al., 2012) as well as a key contributor to GHG emissions through land-use change (Paustian et al., 2006).

Agricultural technologies acting on direct drivers of biodiversity and ecosystem change include improvements in crop yields and resilience; sustainable livestock, fishing, and aquaculture practices; and mechanisation and engineering practices such as precision farming (Beddington, 2010). In addition to shaping current practice, the introduction of new technologies can result in entirely new markets, particularly in confluence with government incentives, as illustrated in the case of biofuels (see Box 3.5). In a potential future of 9 billion inhabitants, some argue that genetically modified crops hold the promise of increasing yields in productive land as well as allowing for cultivation in previously intolerant environments (Fedoroff et al., 2010; Godfray et al., 2010b), potentially resulting in a net biodiversity increase (Carpenter, 2011). Protection of existing genetic diversity in the form of wild crop and livestock varieties is key to safeguarding against future environmental change (Mace et al., 2012). Indeed, the presence of wild varieties is essential to isolating yield-boosting genes as well as other desired qualities such as drought and flood resistance (Normile, 2008).

Box 3.5: Bioenergy and Indirect Land Use Change

The Global Biosphere Management Model (GLOBIOM) developed by IIASA is used to illuminate the complex interplay of agricultural, bioenergy, and forestry production sectors on land use change. GLOBIOM is a partial equilibrium economic model focused on specific economic sectors (18 most important crops, 7 livestock products, full forestry and bioenergy supply chains) and encompassing 30 world regions in variable degrees of resolution and disaggregation. The model is supported by a comprehensive geo-spatial database (Skalský et al., 2008) that informs production potential and simulates under a dynamic recursive framework land use changes by 10 year intervals up to 2100. Indirect GLOBIOM drivers are an exogenous GDP and population growth projections which together with food consumption per capita (FAO-based) allow for the simulation of supply and demand, commodity markets, and international trade. Further, GLOBIOM also represents technological progress in crop and livestock production and land conversion constraints related to biophysical or policy restrictions. Direct drivers are model outputs including spatially explicit land use change, GHG emissions, water use, biomass extraction, and nutrient balances.

The confluence of bioenergy technologies and government subsidies illustrates the potential for emerging technologies to create new markets with complex synergies and feedbacks. Coupled with market feedback mechanisms, GLOBIOM is capable of modelling a wide range of environmental scenarios and has been recently employed to cast light on the debate surrounding the impact of expanded biofuel production on indirect land use change (Havlik et al., 2011). Here the model shows that first generation biofuels generation (e.g., ethanol and biodiesel) lead to greater deforestation than ‘no biofuels’ under all scenarios and have a negative net effect on global GHG levels through increased indirect land use change emissions. Adoption of second generation biofuels (derived from woody biomass) produced through existing production forests leads to the lowest cumulative deforestation as well as greatest decrease (27%) in overall GHG emissions. Second generation biofuels are thus the most advantageous from the perspective of limiting GHG; however, externalities are highly contingent on the feedstock source, with tree plantations established on cropland and grassland leading to the greatest amount of deforestation and water consumption.

3.4 Scenarios and models of direct drivers

Anthropogenic direct drivers are to a significant extent driven by the indirect drivers outlined in Section 3.3. Direct drivers impact biodiversity and ecosystem change at a more proximate level, frequently involving synergies with other direct drivers, and ultimately feeding back into indirect drivers. Salafsky et al., (2008) provide an exhaustive and detailed list of direct threats to biodiversity that broadly fall under the rubric of land-use change, climate change and pollution, natural resource use and exploitation, and invasive species. Within the following sub-sections a general overview of each driver is provided followed by a description of prominent scenarios, models, and case studies. As

with indirect drivers, direct drivers are subject to differing types of uncertainty and are not equally represented in the existing scenario and modelling literature (Table 3.3).

Table 3.3

Degree of uncertainty and utilization in scenarios and models by direct driver.

Drivers	Utilization in Scenarios and Models	Stochastic Uncertainty	Scientific Uncertainty	Linguistic Uncertainty
Land Use Change	medium	medium	medium	medium
Climate Change	high	low	low	high
Pollution	low	low	medium	low
Natural Resource Use and Exploitation	low	high	medium	low
Invasive Species	high	high	low	low

3.4.1 Land-use change

Habitat modification is seen as a prime driver of biodiversity loss and changes in the level and composition of ecosystem services provided at any given location. Habitat modification is mostly a result of land-use change, either induced by human action or as a result of changes in the physical determinants of the habitat (e.g., due to changes in hydrology or climate). Habitat modification also occurs in marine environments where trawling has particularly devastating implications for seafloor ecosystems (Hiddink et al., 2006). In most cases the modification of habitat due to human interference is much faster and more pronounced than changes due to climate change (Lehsten et al., 2015). However, in specific environments, such as the arctic tundra region, climate change can also have major impacts on habitat.

Land-use change is the major human influence on habitats and can include the conversion of land cover (e.g., deforestation or mining), changes in the management of the (agro-) ecosystem (e.g., through intensification of agricultural management or forest harvesting; see Box 3.6) or changes in the spatial configuration of the landscape (e.g., fragmentation of habitats) (van Vliet et al., 2012; Verburg et al., 2013b).

At the regional scale, a variety of different models have emerged in the past decades to simulate changes in land use driven by demographic change, policies, and changing demands for land-based commodities or urban use. Model structure and characteristics are often specific to the scale of application, the research questions, and the dominant processes involved. Agent-based models have become popular tools for small areas and when it is important to explicitly represent diversity in land use decision-making (Matthews et al., 2007; Brown et al., 2014). In such models the changing landscape pattern emerges from the decisions of individual land owners and managers that respond to (often exogenously defined) indirect drivers.

At larger spatial and temporal scales, a simpler conceptualisation of decision-making is often applied and land-use change is simulated based on the suitability of locations for a specific land use, with the regional level demands for the different land uses and spatial constraints resulting from regulations and land-use planning (van Delden et al., 2011). In such models pixels are the units of simulation and often the state of neighbouring pixels is accounted for to represent neighbourhood effects and processes such as centripetal forces and economies of scale in urban development. Many global scale land use models use macro-economic representations of commodity markets and trade simulation in general or partial equilibrium models to simulate land-use change between different world regions. In many cases land-use decisions are represented by simulating the land-use choice of a representative farm at the regional level (van Meijl et al., 2006) or at the level of coarse spatial units (Schmitz et al., 2012). Spatial patterns of land-use change are calculated using either simple land allocation algorithms based on land suitability or more complex routines that account for competition between alternative land uses (Van Asselen and Verburg, 2013).

Independent of the scale, most land use models simulate mainly the major conversions of land cover (urbanisation, deforestation, etc.) and ignore the more subtle modifications of habitat conditions due to changes in land management and in the spatial configuration of landscapes (Kuemmerle et al., 2013).

This is due to either a lack of fine-resolution data on landscape elements and linear features or the simplified representation of landscapes by either dominant or fractional land cover (Verburg et al., 2013a).

Box 3.6: Agroforestry

High rates of deforestation near biodiversity hotspots are associated with low rates of human development and high population growth, with human development and economic policies emerging as key factors (Jha and Bawa, 2006). Although there is no substitute for primary forests in terms of biodiversity value (Gibson et al., 2011), traditional agroforestry systems foster greater biodiversity than mono-crop systems (McNeely and Schroth, 2006) and may serve as one method of ensuring socioeconomic livelihoods at the margins of rainforests (Steffan-Dewenter et al., 2007). Agroforestry systems have also been found to reduce dependency on nearby reserves and pristine forests, however, economic incentives are important to offset the cost to farmers of planting and maintaining trees on farmland (Bhagwat et al., 2008). Further governance options include implementing existing conservation frameworks such as REDD (Reducing Emissions from Deforestation and Forest Degradation) in a manner to maximise conservation of high biodiversity areas (Harvey et al., 2010).

3.4.2 Climate change and pollution**Climate change**

Direct driver pathways of climate change are related to changes in climate and weather patterns impacting in-situ ecosystem functioning and causing migration of species and entire ecosystems. There are indications that climate change induced temperature increases may threaten as many as 1 in 6 species at the global level (Urban, 2015).

Rising atmospheric CO₂ concentrations leading to higher ocean temperatures as well as ocean acidification are expected to have profound effects upon marine ecosystems, particularly coral reefs (Hoegh-Guldberg et al., 2007) as well as marine communities near the seafloor (Hale et al., 2011). Recent studies projecting reef contraction due to global warming are unanimous in their depiction of the negative impacts on marine biodiversity that depend on these ecosystems (e.g., Pandolfi et al., 2011) although the direct effects of ocean acidification are highly variable across different taxa (Hendriks et al., 2010).

The construction of climate driver scenarios starts with a forcing on the climate system expressed in irradiance (watts per square meter). For the IPCC Fifth Assessment Report, emissions scenarios consistent with climate forcing targets have been constructed as Representative Concentration Pathways (RCPs) by a community effort of Integrated Assessment Modelling groups with the aim to inform Global Circulation Models and Earth System Models. The biodiversity and ecosystem services relevant variables characterising RCP scenarios include characteristics of land-use scenarios, which were downscaled to provide spatially explicit land-use maps to the climate modelling community. Gridded land-use transition data for the past and future time period has been developed from the reconstruction based on HYDE 3 agricultural data and FAO wood harvest data, and the future land-use scenarios from Integrated Assessment Models. These gridded land-use datasets are used as a forcing for some Earth System Models participating in the Coupled Model Intercomparison Project experiments, to assess the biogeochemical and biogeophysical effects of land-use and land-cover change in the climate change simulation.

The Inter-Sectoral Impact Model Intercomparison Project (ISI-MIP) used climate change projections to make impact assessments in different Earth system sectors and at different scales. Based on common background scenarios, uncertainties across multiple impact models have been derived. ISI-MIP aims to establish a longer-term coordinated impact assessment effort driven by the entire impact community covering all biodiversity and ecosystem services sectors on global scales and for selected regional and ecosystem specific case studies. In this way feedbacks between managing biodiversity and ecosystem services sectors, climate, and Earth systems can be studied in a loosely coupled manner. Currently a few groups aim to fully couple all three models types (Global Circulation Models, Earth System Models, and Integrated Assessment Models) where the latter cover both the climate mitigation and adaptation functions of ecosystem management. Using such full coupling, climate drivers and their biodiversity and ecosystem services feedbacks can be consistently analysed. In the decades to come it can be expected that decision support tools become more useful as the temporal (incl. climate extremes) and spatial resolution of climate signals improve and more transient model runs are available (Fuss et al., 2015).

Box 3.7: IPCC Scenarios

Global scale long-run environmental assessments are typically framed in consistency with existing scenario storylines such as the IPCC Special Report on Emission Scenarios (Nakicenovic and Swart, 2000). The scenarios of the Intergovernmental Panel for Climate Change, the Millennium Ecosystem Assessment, the Global Biodiversity Outlook, the Global Environment Outlook and the Global Desert Outlook have used these storylines or close derivatives of these to generate indirect driver scenarios for their sector specific outlooks. Regional assessments of the Millennium Ecosystem Assessment and the national variants of the Global Environment Outlook, such as those carried out in the United Kingdom, China, and Brazil, have used globally consistent regional variants of existing storylines. Downscaled gridded scenarios of socioeconomic drivers of SRES (Grübler et al., 2007) have been used as indirect drivers of forest cover change (Kindermann et al., 2008). Climate change scenarios are typically provided on the same grid resolution and are used as direct drivers of ecosystem change (e.g., Seidl et al., 2014). Local and more regional specific scenarios of indirect and direct drivers are typically constructed bottom-up and may significantly

deviate from the globally established storylines. More recently, associations or even directing mapping of such bottom-up scenarios into global storylines were performed allowing for increased comparability across regional case studies (e.g., Vervoort, 2013).

The Special Report on Emissions Scenarios (SRES) (Nakicenovic and Swart, 2000) long employed by the IPCC have given way to a new framework formed by the confluence of the RCPs and the SSPs. RCPs are constructed from radiative forcing targets and present a range of potential futures consisting of a low mitigation scenario, two stabilisation scenarios, and one high baseline scenario (Van Vuuren et al., 2011). SSPs as newly formulated by O'Neill et al., (2014) illustrate socioeconomic factors that would make meeting mitigation and adaptation more or less difficult. Building on previous work integrating SRES with socioeconomic scenarios (Abildtrup et al., 2006), this new model takes the form of a dual axis matrix with RCPs representing the possible trajectories of climate change drivers (Moss et al., 2010; Van Vuuren et al., 2011), and SSPs representing possible socioeconomic developments that would impact the ability to mitigate and adapt to climate changes (van Vuuren et al., 2012b).

Pollution

Pollution is an important driver of biodiversity and ecosystem change throughout all biomes with particularly devastating direct effects on freshwater and marine habitats. Due to its multifaceted nature, scenario analyses are frequently tailored to the specific subclass of pollution under consideration.

The early reports of the effect of the organochlorine insecticides DDT, along with its analogue DDD, on the western grebe (Garrett, 1977) is one of the most documented examples of the biodiversity-pollution nexus. The end of DDT use in early 1970s in many countries has already contributed to the recovery of many of the impacted populations. Incidents of massive killing of marine mammals caused by contamination with the polychlorinated biphenyl (PCBs) and other persistent organic pollutants (POPs) that belong to the same organochlorine family were frequently reported (Kannan et al., 2000; Shaw et al., 2005). More recently, veterinary diclofenac used to treat livestock throughout South Asia has been implicated in the collapse of vulture populations (Oaks et al., 2004) with significant ecosystem services implications (Ogada et al., 2012).

The biodiversity of soil fauna is vital to many ecosystem services including carbon storage, soil fertility and plant diversity, and control of insect populations (Wolters, 2001). Degradation of soil biodiversity through industrial pollution can result in the proliferation of invasive and destructive species as well as the loss of endemic microorganisms (Hafez and Elbestawy, 2009). In addition to above ground plant biodiversity declines, ongoing soil biodiversity loss due to agricultural intensification is likely to impair ecosystem multifunctionality, resulting in decreased carbon sequestration as well as greater nitrogen emissions and phosphorous leaching among other impacts (Wagg et al., 2014).

At a global level, the atmospheric deposition of nitrogen has been recognised as one of the most important threats to the integrity of global biodiversity (Sala et al., 2000; Butchart et al., 2010). Once nitrogen is deposited on terrestrial ecosystems, a cascade of effects can occur that often leads to overall declines in biodiversity (Bobbink et al., 2010). Within terrestrial biomes, nitrogen deposition through fossil fuels and fertiliser use has been found to impede decomposition and slow microbial growth, with a number of implications for terrestrial biodiversity (Smith et al., 1999; Carreiro et al., 2000; Janssens et al., 2010). Changes in biotic or ecological characteristics are simulated in response to environmental drivers using mathematical representations of the most important processes. Such process based models are useful for assessing temporal trends and response times. However, they often require a large amount of data for model calibration (Dise et al., 2011).

While terrestrial ecosystems have been affected by nitrogen-phosphorous fertilisers, these have had a far more pernicious effect on the biodiversity of freshwater and marine habitats, leading to eutrophication and hypoxic or 'dead' zones that support no aquatic life. Eutrophication and acidification occur when nitrogen and phosphorous – the primary limiting factors for algal growth – are introduced, allowing algal blooms to proliferate which deplete the water of oxygen as well as frequently result in toxic algae (Camargo and Alonso, 2006). At a regional scale, various scenario analyses have examined the impact of reduced nutrient loads on coastal ecosystems in the North Sea (e.g., Skogen et al., 2004; Lenhart et al., 2010). Integrated approaches to modelling nutrient emissions have also been conducted on a global scale using the Millennium Ecosystem Assessment storylines and the Global Nutrient export from Watersheds (NEWS) model, highlighting the role of indirect drivers on future nutrient emissions (Seitzinger et al., 2010).

Plastic debris is emerging as one of the most potent pollutants of marine environments. Results from an ocean circulation model HYCOM (Hybrid Coordinate Ocean Model) coupled with particle-tracking model Pol3DD estimate that 5.25 trillion plastic particles weighing 268,940 tons are in the world's oceans (Eriksen et al., 2014). The potential for plastic debris to travel considerable distances, its resistance to biodegradation, and its potential to accumulate in habitats far from its point of origin present a distinct challenge (sCBD, 2012). In addition to the direct introduction of microplastics used in commercial cleaning processes as well as plastic pellets and powders (Barnes et al., 2009), larger pieces of plastic are degraded by the effects of heat, wave action, and UV, eventually forming microplastics and nanoplastics ranging from 5µ to 200 nm in diameter (Ryan et al., 2009; Andrady, 2011; Sundt et al., 2014). The

ingestion of such plastics by aquatic life can lead to physical blockages resulting in mortality as well as accumulation of persistent organic pollutants throughout the food chain (Box 3.8). This problem is particularly pronounced near the ocean floor where higher density plastics accumulate and are consumed by benthic scavengers which serve as a vector to higher trophic organisms (Wright et al., 2013). In addition to ingestion of plastics, entanglement in plastic loops and ‘ghost nets’ affects a number of marine animals, resulting in strangulation and reduced fitness (Derraik, 2002). According to sCBD (2012), impacts of marine debris were reported for 663 species.

Plastic pieces also serve as long-lasting vectors of transport across marine environments, introducing invasive species to the detriment of endemic biota (Gregory, 2009). Further, there is growing evidence that microplastics absorb POPs, serving as a high concentrate vector of transport and ingestion by marine organisms (Teuten et al., 2009). Compounding this phenomenon, climate change has greatly expanded the habitable range of many generalists that are now able to take advantage of such vectors, illustrating the complex interlinkages among biodiversity and ecosystem services direct drivers.

Box 3.8: Persistent Organic Pollutants

POPs are a group of chemicals that include some pesticides, some industrial chemicals, dioxins, and furans. The use of POPs was banned according to Stockholm Convention on Persistent Organic Pollutant which came into force in 2004 (Ahmed, 2006). The tendency of POPs to dissolve and bioaccumulate in fat tissues, subsequently bioamplifying through food chains, has enabled them to build up in tissues, reaching very high concentrations in organisms at the top of the food chain, causing serious impacts and possible massive death. Recently, various reports have emerged to document the deleterious effect of endocrine disturbing chemicals (EDCs), a group of chemicals that include pesticides, industrial chemicals, metals, personal care products, and others on endocrine systems (Bergman et al., 2013). Other potential pollutants that impact biodiversity would include heavy metals (Mulder and Breure, 2006), nutrients (Ochoa-Hueso et al., 2011), and systemic pesticides (van der Sluijs et al., 2015) among others.

Models have been used to depict changes in ecosystems however, with the complexity of the biological system, there is little consensus on the basic equations for describing physical systems (James, 2002). As one example, Aquatox is one of the most widely used aquatic ecosystem models. It models chemical fate and effects as a prelude to evaluate past and present, direct and indirect impacts of stressors of aquatic ecosystems. Aquatox can simulate flasks and tanks, ponds and pond enclosures, successive stream reaches, lakes, reservoirs, and estuaries (Park et al., 2008). The model is frequently used in mapping bioaccumulation of pollutants in plants, fish, and shorebirds that feed on aquatic organisms. However, like most water quality models, Aquatox predicts only concentrations of pollutants in water but cannot project the effects of said pollutants.

3.4.3 Natural resource use and exploitation

Anthropogenic exploitation of wildlife has occurred throughout human history leading to biodiversity loss and extinctions, however the recent rate of losses has sharply accelerated (Leakey and Lewin, 1996).

The most overexploited species include marine fish, invertebrates, trees, tropical vertebrates hunted for bushmeat, and species harvested for medicinal and pet trade (MA, 2005a).

As direct drivers of biodiversity and ecosystem change, natural resource use and climate change exhibit interlinkages in the form of climate change induced increases in scientific and stochastic uncertainty related to the modelling and management of natural resources (Nichols et al., 2011).

Trade in bushmeat is one of the greatest threats to wildlife in the tropics, particularly among large-bodied slow reproducing species. Indeed, in many regions vulnerable species have already been extirpated, resulting in an ‘extinction filter’ where the remaining species are those capable of coping with anthropogenic pressures (Cowlshaw et al., 2005). In addition to being a conservation issue, bushmeat hunting and consumption is intricately tied to the livelihood of households not only as a protein source during periods of low agricultural production, but also as a source of income from sales to more affluent urban households (de Merode et al., 2004; Bennett et al., 2007).

There is a general consensus among conservationists that sustainable bushmeat management and harvesting through better regulation is the best available solution to overexploitation given the socioeconomic contexts in many of the affected regions.

Human activities have severely affected ocean health through overfishing, although there are significant country level differences (Halpern et al., 2012). As the primary driver of the decline in marine resources, overexploitation of marine habitats has led to precipitous drops in commercially valuable species as well as other species subject to bycatch and overfishing (Pauly et al., 2002). The decision to exit a declining fishery is highly contingent on the socioeconomic status of the fisher, with poorer households less likely to leave (Cinner et al., 2009). Further, there is evidence at the local level that proximity to markets and market demand better predict overfishing than population density (Cinner and McClanahan, 2006). Here participatory modelling approaches with greater stakeholder involvement at the local level are highly appropriate for applications involving sustainable governance of natural resources (Videira et al., 2010), with particular salience for management of fisheries (Röckmann et al., 2012).

Trade in ornamental species including vertebrates associated with traditional Chinese medicine has led to significant biodiversity losses, particularly within the Southeast Asian region (Sodhi et al., 2004; Nijman, 2010). Further, trade in aquatic ornamental fish serves as vector for the spread of invasive species (Padilla and Williams, 2004). As a direct driver, natural resource use and exploitation is heavily influenced by indirect drivers such as socioeconomic and demographic trends as well as societal and cultural influences. Indeed, per capita consumption levels are emerging as a potentially more important driver of biodiversity and ecosystems change than population growth (Toth and Sziget, 2016). Models and scenarios of natural resource consumption and exploitation therefore need to be intimately tied to economic and sociocultural trends.

3.4.4 Invasive Species

Invasive species may be indigenous and/or exotic/alien and occur mostly in the terrestrial and aquatic ecosystems (marine and fresh water), disrupting the ecological functioning of natural systems. Invasive species outcompete local and indigenous species for natural resources with negative implications for biodiversity. A number of invasive and alien species or weeds and invasive species have been reported in various parts of the world, resulting in a loss in biodiversity at local and regional scales causing significant economic damage (Mack et al., 2000).

The type and extent of invasive species will depend on the drivers which, for terrestrial environments, mainly include the type of habitat, soil, climatic conditions, and the degree of disturbance. The dispersion of invasive species has been extensively studied as a function of both climate and land use change with the general finding that climate change is conducive to increased invasions in both terrestrial and marine ecosystems (Hellmann et al., 2008; Rahel and Olden, 2008; Walther et al., 2009). The influence of land use change is less clear, however habitat type is a good indicator of invasibility and disturbed habitats (e.g., arable land, anthropogenic herb stands) are more susceptible to invasion (Chytrý et al., 2008). Most invasive species do not have natural enemies in their new environments and have to be removed by chemical, manual, mechanical, and integrated methods.

A number of invasive species related models have been developed and used in depicting invasive species spread, distribution in new areas, and also for quantifying their impacts on environment. Climex, first published in 1980s, is one of the earliest used models of invasive species. The primary output is a mapped prediction of the favourability of a set of locations for a given species, though the model also produces a suite of additional information to allow further understanding of species responses to climate. Bioclimatic envelope models such as Climex have been frequently employed to map species distribution however the predictive accuracy of such models can vary substantially according to inclusion of topographic heterogeneity and CO₂ concentrations (Willis and Bhagwat, 2009). Spatially explicit models (Modular Dispersal in GIS, MDiG) were designed as an open-source modular framework for dispersal simulation integrated within a GIS (Geographic Information System). The model modules were designed to model an approximation of local diffusion, long distance dispersal, growth, and chance population mortality based on the underlying suitability of a region for establishment of a viable population (Pitt, 2008).

Box 3.9: Invasive Species within the South African Context

Of the approximately 8,750 alien species introduced into South Africa, 161 are seriously invasive, while others have the potential to become invasive in the future (Van Wilgen et al., 2001). In the arid- and semi-arid savannah and grassland biomes of Southern Africa, invasive species occur in areas that are degraded, mostly in rangelands that have been disturbed by overgrazing or mismanagement, negatively impacting the grazing capacity of the area. This thickening of indigenous woody species (also called bush encroachment) is caused by species such as *Senegalia mellifera* (black thorn), *Terminalia sericea* (terpentine bush), *Vachellia tortilis* (umbrella thorn), and *Dichrostachys cinerea* (sickle bush). High density woody alien species, such as members of the *Prosopis* species (mesquite), compete for moisture with local species, especially in the lower lying riverine areas and valleys. *Prosopis* invasions in the Northern Cape Province of South Africa result in an estimated water loss of 8.94 million m³ every year.

3.5 Lessons learned and the way forward

There are a myriad models used to make projections of indirect and direct drivers. This diversity reflects the necessity that ‘every problem requires its own model’ and that one model or model approach alone is unlikely to sufficiently characterise possible futures of driver and driver processes.

Scenarios and models of drivers often need to be specifically tailored to the needs of different policy or decision contexts. Existing approaches can be useful for the data they contain, but rarely deliver meaningful results or even insights if applied without proper adaptation to a particular decision context. There is no single scenario development or modelling tool that serves the needs of the full range of application domains. Even integrated assessment and general equilibrium models, in and of themselves, typically fall short of capturing the necessary details required by biodiversity and ecosystem services applications.

However, although integrated assessment models or general equilibrium models will rarely be the recommended model of choice for a specific biodiversity and ecosystem services study, they may still be indispensable for providing boundary conditions. Linking the macro-model context to specific biodiversity and ecosystem services models will ensure globally consistent local results and sector-specific consistency in a wider socio-economic context.

Given that the science of developing driver scenarios is still maturing, the way forward will require an increased focus on refining strategies to improve characterisation of uncertainties, including notions of ignorance, through improved creativity in building scenario storylines to better characterise possibility spaces of driver sets and their evolution over time. Uncertainty can be elucidated by identifying and eliminating biases, and by increasing precision through making models more data driven where robust data are available. Biases in models are mainly related to spatial, sectoral, and temporal inconsistencies. Strategies for addressing these (and discussed further in Chapter 6) include:

- Clusters of spatially linked models need to be developed to guarantee relevance and consistency of scenarios of biodiversity and ecosystem services change from the global to the local level. Two way spatial coupling of models in combination with hierarchically nested scenario storyline building will ensure that local case studies are consistent with global assumptions and at the same time up-scaling of local knowledge can enrich storylines on larger spatial aggregates (Verburg et al., 2015).
- Interactions of biodiversity and ecosystem services with the wider socioeconomic system will need to be modelled through appropriate response functions or through direct or indirect model linkage with highly resolved driver information needed for a specific biodiversity and ecosystem services study and more aggregated models covering the rest of the socioeconomic system.
- In many cases environmentally-defined spatial scales and units of analysis would be more relevant for biodiversity driver scenarios than other scales and units (e.g., administrative, municipalities, provinces, countries). Laura (2009) assesses the challenges of conserving biodiversity across the US-Mexican border, finding that many problems are often exacerbated by socioeconomic and cultural differences. This study shows how access to relevant information on biodiversity drivers is particularly affected when ecosystems are artificially divided by different administrative regimes. In these cases, information sharing tends to be slow, policy-making processes can be delayed, and key options for protecting shared resources tend to be overlooked.
- The issue of temporal inconsistencies has a long standing history in natural resource management since the introduction of discounting in forest management by Faustmann (1849) and is a strong driver of human impacted ecosystem change and driver management. Harmonising long-term strategies with short-term actions remains a challenge. Forecasting tools for short-term market variables will need to be connected with projection tools carrying out long-run analyses of market and environmental resource variables.

Improvements in the precision of currently existing tools will necessitate the assimilation of large amounts of Earth observation data, market information, and observations describing dimensions of human behaviour and human capital including knowledge of biodiversity and ecosystem services management (see Chapter 8). Data driven approaches to precision improvements will need to be applied to identify parameters of scenario models.

Scenario storyline formulation for indirect and direct drivers has a long tradition in foresight studies, economic analysis, demographics, and more generally in integrated assessment and impact assessment. Most scenario assessments are of a deterministic nature and typically ask the question of what the best policy options would be given a single driver reference scenario. While some biodiversity and ecosystem services studies can be ‘pegged’ to existing driver scenarios or scenario families, in many circumstances new scenarios of indirect and direct drivers departing from existing global environmental assessment scenarios such as IPCC SSPs/ RCPs and Millennium Ecosystem Assessment will need to be constructed to find a better fit with biodiversity and ecosystem services-specific contexts. In this case existing scenarios will serve as reference points and benchmarks for specific biodiversity and ecosystem services driver scenarios. Due to the long lasting nature and irreversibility of many biodiversity and ecosystem services related decisions, the current practice of operating with only one reference driver scenario needs to be augmented by developing multiple reference scenarios entering decision making under uncertainty tools, which will ensure that biodiversity and ecosystem services management strategies are robust under a wide range of possible driver scenarios or at least allow for the transparent assessment of relative risks.

References

- Abildtrup, J., Audsley, E., Fekete-Farkas, M., Giupponi, C., Gylling, M., Rosato, P. and Rounsevell, M., 2006: Socio-economic scenario development for the assessment of climate change impacts on agricultural land use: a pairwise comparison approach. *Environmental science & policy*, 9(2): 101-115.
- Abrahamse, W. and Steg, L., 2013: Social influence approaches to encourage resource conservation: A meta-analysis. *Global Environmental Change*, 23(6): 1773-1785.
- Abunge, C., Coulthard, S. and Daw, T.M., 2013: Connecting marine ecosystem services to human well-being: Insights from participatory well-being assessment in Kenya. *Ambio*, 42(8): 1010-1021.
- Acheson, J.M., 2006: Institutional failure in resource management. *Annu. Rev. Anthropol.*, 35: 117-134.
- Ahmed, M.T., 2006: Persistent organic pollutants in Egypt-an overview. In *Soil and Water Pollution Monitoring, Protection and Remediation*, Springer, 25-38.
- Alcamo, J., 2001: Scenarios as tools for international environmental assessments. European Environment Agency, Environmental issue report 24, Luxembourg.
- Alcamo, J., Van Vuuren, D., Cramer, W., Alder, J., Bennett, E., Carpenter, S., Christensen, V., Foley, J., Maerker, M., Masui, T., Morita, T., O'Neill, B., Peterson, G., Ringler, C., Rosegrant, M. and Schulze, K., 2005: Changes in ecosystem services and their drivers across the scenarios. In *Ecosystems and human well-being: Scenarios*, Volume 2, Washington DC, Island press, 297-373.
- Amarasinghe, U.A., Shah, T. and Singh, O.P., 2007: Changing consumption patterns implications on food and water demand in India. Colombo, Sri Lanka, International Water Management Institute.
- Amer, M., Daim, T.U. and Jetter, A., 2013: A review of scenario planning. *Futures*, 46: 23-40.
- Andrady, A.L., 2011: Microplastics in the marine environment. *Marine Pollution Bulletin*, 62(8): 1596-1605.
- Attwood, C., Cochrane, K.L. and Hanks, C., 2005: Putting into practice the ecosystem approach to fisheries. Rome, Food and Agriculture Organization of the United Nations.
- Augustyn, J., Petersen, S., Shannon, L. and Hamukuaya, H., 2014: Implementation of the Ecosystem Approach to Fisheries in the Benguela Current LME area. In *Governance of Marine Fisheries and Biodiversity Conservation*, John Wiley & Sons, Ltd., 271-284.
- Barbier, E.B., Hacker, S.D., Kennedy, C., Koch, E.W., Stier, A.C. and Silliman, B.R., 2011: The value of estuarine and coastal ecosystem services. *Ecological Monographs*, 81(2): 169-193.
- Barnes, D.K.A., Galgani, F., Thompson, R.C. and Barlaz, M., 2009: Accumulation and fragmentation of plastic debris in global environments. *Philosophical Transactions of the Royal Society B: Biological Sciences*, 364(1526): 1985-1998.
- Barnosky, A.D., Hadly, E.A., Bascompte, J., Berlow, E.L., Brown, J.H., Fortelius, M., Getz, W.M., Harte, J., Hastings, A., Marquet, P.A., Martinez, N.D., Mooers, A., Roopnarine, P., Vermeij, G., Williams, J.W., Gillespie, R., Kitzes, J., Marshall, C., Matzke, N., Mindell, D.P., Revilla, E. and Smith, A.B., 2012: Approaching a state shift in Earth's biosphere. *Nature*, 486(7401): 52-58.
- Bechara, A., Damasio, H., Tranel, D. and Damasio, A.R., 1997: Deciding advantageously before knowing the advantageous strategy. *Science*, 275(5304): 1293-1295.
- Beddington, J., 2010: Food security: contributions from science to a new and greener revolution. *Philosophical Transactions of the Royal Society B: Biological Sciences*, 365(1537): 61-71.
- Bennett, E.L., Blencowe, E., Brandon, K., Brown, D., Burn, R.W., Cowlishaw, G., Davies, G., Dublin, H., Fa, J.E. and Milner-Gulland, E.J., 2007: Hunting for consensus: reconciling bushmeat harvest, conservation, and development policy in West and Central Africa. *Conservation Biology*, 21(3): 884-887.
- Bergman, Å., Heindel, J.J., Jobling, S., Kidd, K.A. and Zoeller, R.T., 2013: State of the science of endocrine disrupting chemicals 2012 United Nations Environment Programme and the World Health Organization.
- Bhagwat, S.A., Willis, K.J., Birks, H.J.B. and Whittaker, R.J., 2008: Agroforestry: a refuge for tropical biodiversity? *Trends in Ecology & Evolution*, 23(5): 261-267.
- Blake, J., 1999: Overcoming the 'value-action gap' in environmental policy: Tensions between national policy and local experience. *Local environment*, 4(3): 257-278.
- Bobbink, R., Hicks, K., Galloway, J., Spranger, T., Alkemade, R., Ashmore, M., Bustamante, M., Cinderby, S., Davidson, E. and Dentener, F., 2010: Global assessment of nitrogen deposition effects on terrestrial plant diversity: a synthesis. *Ecological Applications*, 20(1): 30-59.

- Bousquet, F., Barreteau, O., d'Aquino, P., Etienne, M., Boissau, S., Aubert, S., Le Page, C., Babin, D. and Castella, J.-C., 2002: Multi-agent systems and role games: collective learning processes for ecosystem management. In *Complexity and Ecosystem Management. The Theory and Practice of Multi-Agent Systems*, Janssen, M.A., ed., Londres, Edward Elgar Publishers, 248-286.
- Briot, J.-P., Guyot, P. and Irving, M., 2007: Participatory simulation for collective management of protected areas for biodiversity conservation and social inclusion. *AIS-CMS*, 7: 183-188.
- Brown, C., Murray-Rust, D., van Vliet, J., Alam, S.J., Verburg, P.H. and Rounsevell, M.D., 2014: Experiments in Globalisation, Food Security and Land Use Decision Making. *PLoS ONE*, 9(12): e114213.
- Burney, J.A., Davis, S.J. and Lobell, D.B., 2010: Greenhouse gas mitigation by agricultural intensification. *Proceedings of The National Academy of Sciences*, 107(26): 12052-12057.
- Burt, R.S., Kilduff, M. and Tasselli, S., 2013: Social network analysis: Foundations and frontiers on advantage. *Annual review of psychology*, 64: 527-547.
- Butchart, S.H.M., Walpole, M., Collen, B., van Strien, A., Scharlemann, J.P.W., Almond, R.E.A., Baillie, J.E.M., Bomhard, B., Brown, C., Bruno, J., Carpenter, K.E., Carr, G.M., Chanson, J., Chenery, A.M., Csirke, J., Davidson, N.C., Dentener, F., Foster, M., Galli, A., Galloway, J.N., Genovesi, P., Gregory, R.D., Hockings, M., Kapos, V., Lamarque, J.-F., Leverington, F., Loh, J., McGeoch, M.A., McRae, L., Minasyan, A., Morcillo, M.H., Oldfield, T.E.E., Pauly, D., Quader, S., Revenga, C., Sauer, J.R., Skolnik, B., Spear, D., Stanwell-Smith, D., Stuart, S.N., Symes, A., Tierney, M., Tyrrell, T.D., Vie, J.-C. and Watson, R., 2010: Global Biodiversity: Indicators of Recent Declines. *Science*, 328(5982): 1164-1168.
- Caldwell, J.C., Caldwell, B.K., Caldwell, P., McDonald, P.F. and Schindlmayr, T., 2006: *Demographic transition theory*. Dordrecht, The Netherlands, Springer.
- Camargo, J.A. and Alonso, Á., 2006: Ecological and toxicological effects of inorganic nitrogen pollution in aquatic ecosystems: a global assessment. *Environment International*, 32(6): 831-849.
- Carpenter, S.R., 2002: Ecological Futures: Building an ecology of the long now. *Ecology*, 83(8): 2069-2083.
- Carpenter, S.R., Bennett, E.M. and Peterson, G.D., 2006: Scenarios for ecosystem services: an overview. *Ecology and Society*, 11(1): 29.
- Carpenter, S.R., Cole, J.J., Pace, M.L., Batt, R., Brock, W.A., Cline, T., Coloso, J., Hodgson, J.R., Kitchell, J.F., Seekell, D.A. and others, 2011: Early warnings of regime shifts: a whole-ecosystem experiment. *Science*, 332(6033): 1079-1082.
- Carreiro, M.M., Sinsabaugh, R.L., Repert, D.A. and Parkhurst, D.F., 2000: Microbial enzyme shifts explain litter decay responses to simulated nitrogen deposition. *Ecology*, 81(9): 2359-2365.
- Christakis, N.A. and Fowler, J.H., 2013: Social contagion theory: examining dynamic social networks and human behavior. *Statistics in medicine*, 32(4): 556-577.
- Chytrý, M., Maskell, L.C., Pino, J., Pyšek, P., Vilà, M., Font, X. and Smart, S.M., 2008: Habitat invasions by alien plants: a quantitative comparison among Mediterranean, subcontinental and oceanic regions of Europe. *Journal of Applied Ecology*, 45(2): 448-458.
- Cinner, J.E. and McClanahan, T.R., 2006: Socioeconomic factors that lead to overfishing in small-scale coral reef fisheries of Papua New Guinea. *Environmental Conservation*, 33(01): 73-80.
- Cinner, J.E., Daw, T. and McClanahan, T.R., 2009: Socioeconomic factors that affect artisanal fishers' readiness to exit a declining fishery. *Conservation Biology*, 23(1): 124-130.
- Cowlishaw, G., Mendelson, S. and Rowcliffe, J., 2005: Evidence for post-depletion sustainability in a mature bushmeat market. *Journal of Applied Ecology*, 42(3): 460-468.
- Cross, A., 2003: Drawing up guidelines for the collection and use of expert advice: the experience of the European Commission. *Science and Public Policy*, 30(3): 189-192.
- Crutzen, P.J., 2006: *The "anthropocene"*. Springer.
- Dalkey, N. and Helmer, O., 1963: An experimental application of the Delphi method to the use of experts. *Management science*, 9(3): 458-467.
- Dasgupta, P.S. and Ehrlich, P.R., 2013: Pervasive externalities at the population, consumption, and environment nexus. *Science*, 340(6130): 324-328.
- Day, O., 2009: *The impacts of climate change on biodiversity in Caribbean islands: what we know, what we need to know, and building capacity for effective adaptation*. Caribbean National Resources Institute, 386,

- de Merode, E., Homewood, K. and Cowlshaw, G., 2004: The value of bushmeat and other wild foods to rural households living in extreme poverty in Democratic Republic of Congo. *Biological Conservation*, 118(5): 573-581.
- Deaton, A. and Drèze, J., 2009: Food and nutrition in India: facts and interpretations. *Economic and political weekly*, 44(7): 42-65.
- Delgado, C.L., 2003: Rising consumption of meat and milk in developing countries has created a new food revolution. *The Journal of Nutrition*, 133(11): 3907S-3910S.
- Derraik, J.G.B., 2002: The pollution of the marine environment by plastic debris: a review. *Marine Pollution Bulletin*, 44(9): 842-852.
- Dietrich, J.P., Schmitz, C., Lotze-Campen, H., Popp, A. and Müller, C., 2014: Forecasting technological change in agriculture—an endogenous implementation in a global land use model. *Technological Forecasting and Social Change*, 81: 236-249.
- Dietz, T., Rosa, E.A. and York, R., 2007: Driving the human ecological footprint. *Frontiers in Ecology and the Environment*, 5(1): 13-18.
- Dise, N.B., Ashmore, M., Belyazid, S., Bleeker, A., Bobbink, R., de Vries, W., Erisman, J.W., Spranger, T., Stevens, C.J. and van den Berg, L., 2011: Nitrogen as a threat to European terrestrial biodiversity. In *The European nitrogen assessment*, Sutton, M., Howard, C., Erisman, J.W., Billen, G., Bleeker, A., Grennfelt, P., van Grinsven, H. and Grizzetti, eds., Cambridge University Press.
- Ellis, E.C., 2011: Anthropogenic transformation of the terrestrial biosphere. *Philosophical Transactions of the Royal Society of London A: Mathematical, Physical and Engineering Sciences*, 369(1938): 1010-1035.
- Eriksen, M., Lebreton, L.C.M., Carson, H.S., Thiel, M., Moore, C.J., Borerro, J.C., Galgani, F., Ryan, P.G. and Reisser, J., 2014: Plastic Pollution in the World's Oceans: More than 5 Trillion Plastic Pieces Weighing over 250,000 Tons Afloat at Sea. *PLoS ONE*, 9(12): e111913.
- Erlandsen, S. and Nymo, R., 2008: Consumption and population age structure. *Journal of Population Economics*, 21(3): 505-520.
- European Commission, 2001: Directive 2001/42/EC of the European Parliament and of the Council of 27 June 2001 on the assessment of the effects of certain plans and programmes on the environment. 30-37.
- Evenson, R.E. and Gollin, D., 2003: Assessing the impact of the Green Revolution, 1960 to 2000. *Science*, 300(5620): 758-762.
- Faber, A. and Frenken, K., 2009: Models in evolutionary economics and environmental policy: Towards an evolutionary environmental economics. *Technological Forecasting and Social Change*, 76(4): 462-470.
- FAO, 2010: The second report on the state of the world's plant genetic resources for food and agriculture. Rome, Food and Agriculture Organization of the United Nations.
- Faustmann, G., 1849: On the Determination of the Value which Forestland and Immature Lands Possess for Forestry. Translated by Gane, M. Oxford Institute Paper,
- Fedoroff, N.V., Battisti, D.S., Beachy, R.N., Cooper, P.J.M., Fischhoff, D.A., Hodges, C.N., Knauf, V.C., Lobell, D., Mazur, B.J. and Molden, D., 2010: Radically rethinking agriculture for the 21st century. *Science*, 327(5967): 833.
- Fernandes, P.G. and Cook, R.M., 2013: Reversal of fish stock decline in the Northeast Atlantic. *Current Biology*, 23(15): 1432-1437.
- Fidelman, P., Evans, L., Fabinyi, M., Foale, S., Cinner, J. and Rosen, F., 2012: Governing large-scale marine commons: Contextual challenges in the Coral Triangle. *Marine Policy*, 36(1): 42-53.
- Fletcher, W.J., 2002: National ESD reporting framework for Australian fisheries: the 'how to' guide for wild capture fisheries. Department of Fisheries WA/Fisheries Research & Development Corporation.
- Fuss, S., Havlík, P., Szolgayová, J., Schmid, E., Reuter, W.H., Khabarov, N., Obersteiner, M., Ermoliev, Y., Ermolieva, T. and Kraxner, F., 2015: Global food security and adaptation under crop yield volatility. *Technological Forecasting and Social Change*, 98: 223-233.
- Garrett, R.L., 1977: Potential western grebe extinction on California lakes. *Transactions of the Western Section of the Wildlife Society*, 13: 80-89.
- Gerland, P., Raftery, A.E., Ševčíková, H., Li, N., Gu, D., Spoorenberg, T., Alkema, L., Fosdick, B.K., Chunn, J. and Lalic, N., 2014: World population stabilization unlikely this century. *Science*, 346(6206): 234-237.

- Gibson, C.C., Williams, J.T. and Ostrom, E., 2005: Local enforcement and better forests. *World development*, 33(2): 273-284.
- Gibson, L., Lee, T.M., Koh, L.P., Brook, B.W., Gardner, T.A., Barlow, J., Peres, C.A., Bradshaw, C.J.A., Laurance, W.F., Lovejoy, T.E. and Sodhi, N.S., 2011: Primary forests are irreplaceable for sustaining tropical biodiversity. *Nature*, 478(7369): 378-381.
- Godfray, H.C.J., Crute, I.R., Haddad, L., Lawrence, D., Muir, J.F., Nisbett, N., Pretty, J., Robinson, S., Toulmin, C. and Whiteley, R., 2010: The future of the global food system. *Philosophical Transactions of the Royal Society B: Biological Sciences*, 365(1554): 2769-2777.
- Godfray, H.C.J., Beddington, J.R., Crute, I.R., Haddad, L., Lawrence, D., Muir, J.F., Pretty, J., Robinson, S., Thomas, S.M. and Toulmin, C., 2010: Food security: the challenge of feeding 9 billion people. *Science*, 327(5967): 812-818.
- Gomez-Baggethun, E. and Ruiz-Perez, M., 2011: Economic valuation and the commodification of ecosystem services. *Progress in Physical Geography*, 35(5): 613-628.
- Gregory, M.R., 2009: Environmental implications of plastic debris in marine settings—entanglement, ingestion, smothering, hangers-on, hitch-hiking and alien invasions. *Philosophical Transactions of the Royal Society B: Biological Sciences*, 364(1526): 2013-2025.
- Grübler, A., O'Neill, B., Riahi, K., Chirkov, V., Goujon, A., Kolp, P., Prommer, I., Scherbov, S. and Slentoe, E., 2007: Regional, national, and spatially explicit scenarios of demographic and economic change based on SRES. *Technological Forecasting and Social Change*, 74(7): 980-1029.
- Gupta, J. and Pahl-Wostl, C., 2013: Editorial on global water governance. *Ecology and Society*, 18(4): 54.
- Hafez, E.E. and Elbestawy, E., 2009: Molecular characterization of soil microorganisms: effect of industrial pollution on distribution and biodiversity. *World Journal of Microbiology and Biotechnology*, 25(2): 215-224.
- Haidt, J., 2001: The emotional dog and its rational tail: a social intuitionist approach to moral judgment. *Psychological review*, 108(4): 814.
- Hale, R., Calosi, P., McNeill, L., Mieszkowska, N. and Widdicombe, S., 2011: Predicted levels of future ocean acidification and temperature rise could alter community structure and biodiversity in marine benthic communities. *Oikos*, 120(5): 661-674.
- Halpern, B.S., Longo, C., Hardy, D., McLeod, K.L., Samhour, J.F., Katona, S.K., Kleisner, K., Lester, S.E., O'Leary, J., Ranelletti, M., Rosenberg, A.A., Scarborough, C., Selig, E.R., Best, B.D., Brumbaugh, D.R., Chapin, F.S., Crowder, L.B., Daly, K.L., Doney, S.C., Elfes, C., Fogarty, M.J., Gaines, S.D., Jacobsen, K.I., Karrer, L.B., Leslie, H.M., Neeley, E., Pauly, D., Polasky, S., Ris, B., St Martin, K., Stone, G.S., Sumaila, U.R. and Zeller, D., 2012: An index to assess the health and benefits of the global ocean. *Nature*, 488(7413): 615-620.
- Hannagan, R.J. and Larimer, C.W., 2010: Does gender composition affect group decision outcomes? Evidence from a laboratory experiment. *Political Behavior*, 32(1): 51-67.
- Harrison, P.A., Holman, I.P. and Berry, P.M., 2015: Assessing cross-sectoral climate change impacts, vulnerability and adaptation: an introduction to the CLIMSAVE project. *Climatic Change*, 128(3-4): 153-167.
- Harvey, C.A., Dickson, B. and Kormos, C., 2010: Opportunities for achieving biodiversity conservation through REDD. *Conservation Letters*, 3(1): 53-61.
- Haug, C., Rayner, T., Jordan, A., Hildingsson, R., Stripple, J., Monni, S., Huitema, D., Massey, E., van Asselt, H. and Berkhout, F., 2010: Navigating the dilemmas of climate policy in Europe: evidence from policy evaluation studies. *Climatic Change*, 101(3-4): 427-445.
- Havlík, P., Schneider, U.A., Schmid, E., Böttcher, H., Fritz, S., Skalský, R., Aoki, K., De Cara, S., Kindermann, G. and Kraxner, F., 2011: Global land-use implications of first and second generation biofuel targets. *Energy Policy*, 39(10): 5690-5702.
- Hellmann, J.J., Byers, J.E., Bierwagen, B.G. and Dukes, J.S., 2008: Five Potential Consequences of Climate Change for Invasive Species. *Conservation Biology*, 22(3): 534-543.
- Helming, K., Diehl, K., Kuhlman, T., Bach, H., Dilly, O., König, B., Kuhlman, M., Perez-Soba, M., Sieber, S., Tabbush, P., Tscherning, D., Wascher, D. and Wiggering, H., 2011: Ex ante impact assessment of policies affecting land use, part A: analytical framework. *Ecology and Society*, 16(1): 27.
- Hendriks, I.E., Duarte, C.M. and Álvarez, M., 2010: Vulnerability of marine biodiversity to ocean acidification: A meta-analysis. *Estuarine, Coastal and Shelf Science*, 86(2): 157-164.

- Herrero, M., Havlik, P., Valin, H., Notenbaert, A., Rufino, M.C., Thornton, P.K., Blummel, M., Weiss, F., Grace, D. and Obersteiner, M., 2013: Biomass use, production, feed efficiencies, and greenhouse gas emissions from global livestock systems. *Proceedings of The National Academy of Sciences*, 110(52): 20888-20893.
- Hiddink, J.G., Jennings, S., Kaiser, M.J., Queirós, A.M., Duplisea, D.E. and Piet, G.J., 2006: Cumulative impacts of seabed trawl disturbance on benthic biomass, production, and species richness in different habitats. *Canadian Journal of Fisheries and Aquatic Sciences*, 63(4): 721-736.
- Hoegh-Guldberg, O., Mumby, P.J., Hooten, A.J., Steneck, R.S., Greenfield, P., Gomez, E., Harvell, C.D., Sale, P.F., Edwards, A.J., Caldeira, K., Knowlton, N., Eakin, C.M., Iglesias-Prieto, R., Muthiga, N., Bradbury, R.H., Dubi, A. and Hatziolos, M.E., 2007: Coral Reefs Under Rapid Climate Change and Ocean Acidification. *Science*, 318(5857): 1737-1742.
- Hoffmann, M., Duckworth, J.W., Holmes, K., Mallon, D.P., Rodrigues, A.S.L. and Stuart, S.N., 2015: The difference conservation makes to extinction risk of the world's ungulates: Ungulate conservation. *Conservation Biology*, 5: 1303-1313.
- Hosonuma, N., Herold, M., De Sy, V., De Fries, R.S., Brockhaus, M., Verchot, L., Angelsen, A. and Romijn, E., 2012: An assessment of deforestation and forest degradation drivers in developing countries. *Environmental Research Letters*, 7(4): 044009.
- Huitema, D., Jordan, A., Massey, E., Rayner, T., Van Asselt, H., Haug, C., Hildingsson, R., Monni, S. and Stripple, J., 2011: The evaluation of climate policy: theory and emerging practice in Europe. *Policy Sciences*, 44(2): 179-198.
- IEEP, Alterra, Ecologic, PBL and UNEP-WCMC, 2009: Scenarios and models for exploring future trends of biodiversity and ecosystem services changes. Final report to the European Commission, DG Environment on Contract ENV.G.1/ETU/2008/0090r. Institute for European Environmental Policy, Alterra Wageningen UR, Ecologic, PBL Netherlands Environmental Assessment Agency, United Nations Environment Programme World Conservation Monitoring Centre.,
- Illescas, J.M. and Riqch'arina, T., 2007: El desarrollo o desenvolvimiento de lo humano integral originario y el desarrollo sostenible de occidente. In *Alternativas a la reforma educativa neocolonizadora: educación intra e intercultural*, Delgado Burgoa, F., ed., La Paz, Bolivia, Plural Ed. [u.a.]. (Serie Cosmovisión y ciencias 1).
- IPCC, 2001: Climate change 2001: Impacts, adaptation, and vulnerability: contribution of Working Group II to the third assessment report of the Intergovernmental Panel on Climate Change, 978-0-521-80768-5 978-0-521-01500-4, Cambridge, UK ; New York.
- IPCC, 2014: Climate Change 2014 Synthesis Report. Intergovernmental panel on climate change, IPCC Fifth Assessment Report [Core Writing Team, R.K. Pachauri and L.A. Meyer (eds.)], Geneva, Switzerland.
- James, I.D., 2002: Modelling pollution dispersion, the ecosystem and water quality in coastal waters: a review. *Environmental Modelling & Software*, 17(4): 363-385.
- Jann, W. and Wegrich, K., 2007: 4 Theories of the Policy Cycle. In *Handbook of Public Policy Analysis: Theory, Politics, and Methods*, Fischer, F., Miller, G.J. and Sidney, M.S., eds., Boca Raton, FL, CRC Press, Taylor & Francis Group, 43-62.
- Janssens, I.A., Dieleman, W., Luyssaert, S., Subke, J.-A., Reichstein, M., Ceulemans, R., Ciais, P., Dolman, A.J., Grace, J. and Matteucci, G., 2010: Reduction of forest soil respiration in response to nitrogen deposition. *Nature Geoscience*, 3(5): 315-322.
- Jha, S. and Bawa, K.S., 2006: Population growth, human development, and deforestation in biodiversity hotspots. *Conservation Biology*, 20(3): 906-912.
- Joppa, L.N. and Pfaff, A., 2010: Global protected area impacts. *Proceedings of the Royal Society B: Biological Sciences*: rspb20101713.
- Jump, A.S., Marchant, R. and Penuelas, J., 2009: Environmental change and the option value of genetic diversity. *Trends in plant science*, 14(1): 51-58.
- Kannan, K., Blankenship, A.L., Jones, P.D. and Giesy, J.P., 2000: Toxicity Reference Values for the Toxic Effects of Polychlorinated Biphenyls to Aquatic Mammals. *Human and Ecological Risk Assessment: An International Journal*, 6(1): 181-201.
- Kindermann, G.E., McCallum, I., Fritz, S. and Obersteiner, M., 2008: A global forest growing stock, biomass and carbon map based on FAO statistics. *Silva Fennica*, 42(3): 387.

- Kissinger, M. and Rees, W.E., 2010: An interregional ecological approach for modelling sustainability in a globalizing world—Reviewing existing approaches and emerging directions. *Ecological Modelling*, 221(21): 2615-2623.
- Kok, K., van Vliet, M., Bärlund, I., Dubel, A. and Sendzimir, J., 2011: Combining participative backcasting and exploratory scenario development: experiences from the SCENES project. *Technological Forecasting and Social Change*, 78(5): 835-851.
- Kok, K., Bärlund, I., Flörke, M., Holman, I., Gramberger, M., Sendzimir, J., Stuch, B. and Zellmer, K., 2015: European participatory scenario development: strengthening the link between stories and models. *Climatic Change*, 128(3-4): 187-200.
- Kollmuss, A. and Agyeman, J., 2002: Mind the gap: why do people act environmentally and what are the barriers to pro-environmental behavior? *Environmental education research*, 8(3): 239-260.
- Krueger, T., Page, T., Hubacek, K., Smith, L. and Hiscock, K., 2012: The role of expert opinion in environmental modelling. *Environmental Modelling & Software*, 36: 4-18.
- Kuemmerle, T., Erb, K., Meyfroidt, P., Müller, D., Verburg, P.H., Estel, S., Haberl, H., Hostert, P., Jepsen, M.R. and Kastner, T., 2013: Challenges and opportunities in mapping land use intensity globally. *Current opinion in environmental sustainability*, 5(5): 484-493.
- Kuhnert, P.M., Martin, T.G. and Griffiths, S.P., 2010: A guide to eliciting and using expert knowledge in Bayesian ecological models. *Ecology Letters*, 13(7): 900-914.
- Kynn, M., 2008: The 'heuristics and biases' bias in expert elicitation. *Journal of the Royal Statistical Society: Series A (Statistics in Society)*, 171(1): 239-264.
- Lambin, E.F. and Meyfroidt, P., 2011: Global land use change, economic globalization, and the looming land scarcity. *Proceedings of The National Academy of Sciences*, 108(9): 3465-3472.
- Laura, L., 2009: Conservation of shared environments: learning from the United States and Mexico. University of Arizona Press.
- Laurance, W.F., 2004: The perils of payoff: corruption as a threat to global biodiversity. *Trends in Ecology & Evolution*, 19(8): 399-401.
- Leakey, R. and Lewin, R., 1996: The sixth extinction: biodiversity and its survival. Weidenfeld & Nicolson.
- Leclère, D., Havlik, P., Schmid, E., Mosnier, A., Walsh, B., Valin, H., Herrero, M., Khabarov, N. and Obersteiner, M., 2014: Climate change induced transformations of agricultural systems: insights from a global model. *Environmental Research Letters*, 9(12): 124018.
- Lehsten, V., Sykes, M.T., Scott, A.V., Tzanopoulos, J., Kallimanis, A., Mazaris, A., Verburg, P.H., Schulp, C.J.E., Potts, S.G. and Vogiatzakis, I., 2015: Disentangling the effects of land-use change, climate and CO₂ on projected future European habitat types: Disentangling the drivers of habitat change. *Global Ecology and Biogeography*, 24(6): 653-663.
- Lemos, M.C. and Morehouse, B.J., 2005: The co-production of science and policy in integrated climate assessments. *Global Environmental Change*, 15(1): 57-68.
- Lenhart, H.-J., Mills, D.K., Baretta-Bekker, H., van Leeuwen, S.M., der Molen, J.v., Baretta, J.W., Blaas, M., Desmit, X., Kühn, W., Lacroix, G., Los, H.J., Ménesguen, A., Neves, R., Proctor, R., Ruardij, P., Skogen, M.D., Vanhoutte-Brunier, A., Villars, M.T. and Wakelin, S.L., 2010: Predicting the consequences of nutrient reduction on the eutrophication status of the North Sea. *Journal of Marine Systems*, 81(1-2): 148-170.
- Liddle, B. and Lung, S., 2010: Age-structure, urbanization, and climate change in developed countries: revisiting STIRPAT for disaggregated population and consumption-related environmental impacts. *Population and Environment*, 31(5): 317-343.
- Loorbach, D., 2010: Transition management for sustainable development: a prescriptive, complexity-based governance framework. *Governance*, 23(1): 161-183.
- Lowry, K., White, A. and Courtney, C., 2005: National and local agency roles in integrated coastal management in the Philippines. *Ocean & coastal management*, 48(3): 314-335.
- Lutz, W., Butz, W.P. and Samir, K.C., 2014: World population and human capital in the twenty-first century. Oxford University Press.
- MA, 2005: Ecosystems and human well-being: Multiscale assessments, Volume 4. Washington DC, Island Press.
- MA, 2005: Ecosystems and Human Well-being: Scenarios, Volume 2. Washington, DC, Island Press.

- MA, 2005: Ecosystems and human well-being: Biodiversity synthesis. Washington, D.C., World Resources Institute.
- Mace, G.M., Norris, K. and Fitter, A.H., 2012: Biodiversity and ecosystem services: a multilayered relationship. *Trends in Ecology & Evolution*, 27(1): 19-26.
- Machovina, B., Feeley, K.J. and Ripple, W.J., 2015: Biodiversity conservation: The key is reducing meat consumption. *Science of The Total Environment*, 536: 419-431.
- Mack, R.N., Simberloff, D., Lonsdale, W.M., Evans, H., Clout, M. and Bazzaz, F.A., 2000: Biotic Invasions: Causes, Epidemiology, Global Consequences, and Control. *Ecological Applications*, 10(3): 689.
- MacMillan, D.C. and Marshall, K., 2006: The Delphi process—an expert-based approach to ecological modelling in data-poor environments. *Animal Conservation*, 9(1): 11-19.
- Martin, T.G., Kuhnert, P.M., Mengersen, K. and Possingham, H.P., 2005: The power of expert opinion in ecological models using Bayesian methods: impact of grazing on birds. *Ecological Applications*, 15(1): 266-280.
- Matthews, R.B., Gilbert, N.G., Roach, A., Polhill, J.G. and Gotts, N.M., 2007: Agent-based land-use models: a review of applications. *Landscape Ecology*, 22(10): 1447-1459.
- McLellan, R., Iyengar, L., Jeffries, B. and Oerlemans, N., 2014: Living planet report 2014: Species and spaces, people and places. WWF International, Gland.
- McNeely, J.A. and Schroth, G., 2006: Agroforestry and Biodiversity Conservation – Traditional Practices, Present Dynamics, and Lessons for the Future. *Biodiversity and Conservation*, 15(2): 549-554.
- Medina, J., 2014: Economías de la Madre Tierra. Por una nueva comprensión de la economía. La Paz: Ministerio de Medio Ambiente y Agua. Programa Nacional Biocultura, La Paz, Bolivia.
- Mickwitz, P., 2003: A framework for evaluating environmental policy instruments context and key concepts. *Evaluation*, 9(4): 415-436.
- Milton, K., 2013: Environmentalism and cultural theory: exploring the role of anthropology in environmental discourse. Routledge.
- Moilanen, A., Kujala, H. and Leathwick, J.R., 2009: The Zonation framework and software for conservation prioritization. In *Spatial Conservation Prioritization*, A. Moilanen, K.A. Wilson and H.P. Possingham, eds., Oxford, Oxford University Press, 196-210.
- Moser, S. and Mußhoff, O., 2015: Ex-ante Evaluation of Policy Measures: Effects of Reward and Punishment for Fertiliser Reduction in Palm Oil Production. *Journal of Agricultural Economics: Early View*.
- Moss, R.H., Edmonds, J.A., Hibbard, K.A., Manning, M.R., Rose, S.K., van Vuuren, D.P., Carter, T.R., Emori, S., Kainuma, M., Kram, T., Meehl, G.A., Mitchell, J.F.B., Nakicenovic, N., Riahi, K., Smith, S.J., Stouffer, R.J., Thomson, A.M., Weyant, J.P. and Wilbanks, T.J., 2010: The next generation of scenarios for climate change research and assessment. *Nature*, 463(7282): 747-756.
- Mulder, C. and Breure, A.M., 2006: Impact of heavy metal pollution on plants and leaf-miners. *Environmental Chemistry Letters*, 4(2): 83-86.
- Nakićenoć, N. and Swart, R., 2000: Special report on emission scenarios. A special report of working group III of the Intergovernmental Panel on Climate Change. Cambridge, UK, Cambridge University Press.
- Nel, D.C., Cochrane, K., Petersen, S.L., Shannon, L.J., van Zyl, B. and Honig, M.B., 2007: Ecological risk assessment: a tool for implementing an ecosystem approach for southern African fisheries. WWF.
- Nichols, J.D., Koneff, M.D., Heglund, P.J., Knutson, M.G., Seamans, M.E., Lyons, J.E., Morton, J.M., Jones, M.T., Boomer, G.S. and Williams, B.K., 2011: Climate change, uncertainty, and natural resource management. *The Journal of Wildlife Management*, 75(1): 6-18.
- Nijman, V., 2010: An overview of international wildlife trade from Southeast Asia. *Biodiversity and Conservation*, 19(4): 1101-1114.
- Normile, D., 2008: Reinventing rice to feed the world. *Science*, 321: 330-333.
- O'Neill, B.C., Kriegler, E., Riahi, K., Ebi, K.L., Hallegatte, S., Carter, T.R., Mathur, R. and van Vuuren, D.P., 2014: A new scenario framework for climate change research: the concept of shared socioeconomic pathways. *Climatic Change*, 122(3): 387-400.
- Oaks, J.L., Gilbert, M., Virani, M.Z., Watson, R.T., Meteyer, C.U., Rideout, B.A., Shivaprasad, H.L., Ahmed, S., Chaudhry, M.J.I. and Arshad, M., 2004: Diclofenac residues as the cause of vulture population decline in Pakistan. *Nature*, 427(6975): 630-633.

- Ochoa-Hueso, R., Allen, E.B., Branquinho, C., Cruz, C., Dias, T., Fenn, M.E., Manrique, E., Pérez-Corona, M.E., Sheppard, L.J. and Stock, W.D., 2011: Nitrogen deposition effects on Mediterranean-type ecosystems: An ecological assessment. *Environmental Pollution*, 159(10): 2265-2279.
- Ogada, D.L., Keesing, F. and Virani, M.Z., 2012: Dropping dead: causes and consequences of vulture population declines worldwide. *Annals of the New York Academy of Sciences*, 1249(1): 57-71.
- Okoli, C. and Pawlowski, S.D., 2004: The Delphi method as a research tool: an example, design considerations and applications. *Information & Management*, 42(1): 15-29.
- Ostrom, E., 1990: *Governing the commons: The evolution of institutions for collective action*. Cambridge, Cambridge university press.
- Ostrom, E. and Hess, C., 2007: Private and common property rights. Social Science Research Network.
- Ouchi, F., 2004: A literature review on the use of expert opinion in probabilistic risk analysis. World Bank, World Bank Policy Research Working Paper 3201,
- Padilla, D.K. and Williams, S.L., 2004: Beyond ballast water: aquarium and ornamental trades as sources of invasive species in aquatic ecosystems. *Frontiers in Ecology and the Environment*, 2(3): 131-138.
- Palomo, I., Martín-López, B., López-Santiago, C. and Montes, C., 2011: Participatory scenario planning for protected areas management under the ecosystem services framework: the Doñana social-ecological system in southwestern Spain. *Ecology and Society*, 16(1): 23.
- Pandolfi, J.M., Connolly, S.R., Marshall, D.J. and Cohen, A.L., 2011: Projecting Coral Reef Futures Under Global Warming and Ocean Acidification. *Science*, 333(6041): 418-422.
- Park, R.A., Clough, J.S. and Wellman, M.C., 2008: AQUATOX: Modeling environmental fate and ecological effects in aquatic ecosystems. *Ecological Modelling*, 213(1): 1-15.
- Patel, M., Kok, K. and Rothman, D.S., 2007: Participatory scenario construction in land use analysis: An insight into the experiences created by stakeholder involvement in the Northern Mediterranean. *Land Use Policy*, 24(3): 546-561.
- Paustian, K., Antle, J.M., Sheehan, J. and Paul, E.A., 2006: Agriculture's role in greenhouse gas mitigation. Pew Centre on Global Climate Change, Arlington.
- Pedroli, B., Rounsevell, M., Metzger, M., Paterson, J. and Volante consortium, 2015: The VOLANTE Roadmap towards sustainable land resource management in Europe. Alterra Wageningen UR, VOLANTE final project document, Wageningen.
- Perez, C., 2004: Technological revolutions, paradigm shifts and socio-institutional change. In *Globalization, economic development and inequality*, Reinert, E., ed., Edward Elgar, 217-242.
- Peterson, G.D., Cumming, G.S. and Carpenter, S.R., 2003: Scenario Planning: a Tool for Conservation in an Uncertain World. *Conservation Biology*, 17(2): 358-366.
- Pomeroy, R., Garces, L., Pido, M. and Silvestre, G., 2010: Ecosystem-based fisheries management in small-scale tropical marine fisheries: emerging models of governance arrangements in the Philippines. *Marine Policy*, 34(2): 298-308.
- Poteete, A.R. and Ostrom, E., 2004: Heterogeneity, group size and collective action: the role of institutions in forest management. *Development and change*, 35(3): 435-461.
- Pouzols, F.M., Toivonen, T., Di Minin, E., Kukkala, A.S., Kullberg, P., Kuusterä, J., Lehtomäki, J., Tenkanen, H., Verburg, P.H. and Moilanen, A., 2014: Global protected area expansion is compromised by projected land-use and parochialism. *Nature*, 516(7531): 383-386.
- Rahel, F.J. and Olden, J.D., 2008: Assessing the Effects of Climate Change on Aquatic Invasive Species. *Conservation Biology*, 22(3): 521-533.
- Rauch, W., 1979: The Decision Delphi. *Technological Forecasting and Social Change*, 15(3): 159-169.
- Raudsepp-Hearne, C., Peterson, G.D., Tengö, M., Bennett, E.M., Holland, T., Benessaiah, K., MacDonald, G.K. and Pfeifer, L., 2010: Untangling the environmentalist's paradox: why is human well-being increasing as ecosystem services degrade? *Bioscience*, 60(8): 576-589.
- Raymond, C.M., Fazey, I., Reed, M.S., Stringer, L.C., Robinson, G.M. and Evely, A.C., 2010: Integrating local and scientific knowledge for environmental management. *Journal of Environmental Management*, 91(8): 1766-1777.
- Robinson, J., 2003: Future subjunctive: backcasting as social learning. *Futures*, 35(8): 839-856.

- Roc, N., 2008: Haiti-Environment: from the «Pearl of the Antilles» to desolation. FRIDE: Comment September.
- Röckmann, C., Ulrich, C., Dreyer, M., Bell, E., Borodzicz, E., Haapasaari, P., Hauge, K.H., Howell, D., Mäntyniemi, S. and Miller, D., 2012: The added value of participatory modelling in fisheries management—what has been learnt? *Marine Policy*, 36(5): 1072-1085.
- Rothman, D.S., Agard, J., Alcamo, J., Alder, J., Al-Zubari, W.K., aus der Beek, T., Chenje, M., Eickhout, B., Flörke, M. and Galt, M., 2007: The future today. In *Global Environment Outlook 4: Environment for Development* United Nations Environment Programme 397-454.
- Rounsevell, M.D.A. and Metzger, M.J., 2010: Developing qualitative scenario storylines for environmental change assessment. *Wiley Interdisciplinary Reviews: Climate Change*, 1(4): 606-619.
- Ryan, P.G., Moore, C.J., van Franeker, J.A. and Moloney, C.L., 2009: Monitoring the abundance of plastic debris in the marine environment. *Philosophical Transactions of the Royal Society B: Biological Sciences*, 364(1526): 1999-2012.
- Sala, O.E., Stuart Chapin, F., III, Armesto, J.J., Berlow, E., Bloomfield, J., Dirzo, R., Huber-Sanwald, E., Huenneke, L.F., Jackson, R.B., Kinzig, A., Leemans, R., Lodge, D.M., Mooney, H.A., Oesterheld, M.n., Poff, N.L., Sykes, M.T., Walker, B.H., Walker, M. and Wall, D.H., 2000: Global Biodiversity Scenarios for the Year 2100. *Science*, 287(5459): 1770-1774.
- Salafsky, N., Salzer, D., Stattersfield, A.J., Hilton-Taylor, C., Neugarten, R., Butchart, S.H.M., Collen, B., Cox, N., Master, L.L., O'Connor, S. and Wilkie, D., 2008: A standard lexicon for biodiversity conservation: unified classifications of threats and actions. *Conservation Biology*, 22(4): 897-911.
- sCBD, 2012: Impacts of marine debris on biodiversity: Current status and potential solutions. Secretariat of the Convention on Biological Diversity and the Scientific and Technical Advisory Panel—GEF, Technical Series No. 67 67, Montreal, Canada.
- sCBD, 2014: Global Biodiversity Outlook 4. Secretariat of the Convention on Biological Diversity, Montreal.
- Schmitz, C., Biewald, A., Lotze-Campen, H., Popp, A., Dietrich, J.P., Bodirsky, B., Krause, M. and Weindl, I., 2012: Trading more food: Implications for land use, greenhouse gas emissions, and the food system. *Global Environmental Change*, 22(1): 189-209.
- Schulp, C.J.E., Nabuurs, G.-J. and Verburg, P.H., 2008: Future carbon sequestration in Europe—Effects of land use change. *Agriculture, Ecosystems & Environment*, 127(3-4): 251-264.
- Seidl, R., Schelhaas, M.-J., Rammer, W. and Verkerk, P.J., 2014: Increasing forest disturbances in Europe and their impact on carbon storage. *Nature Climate Change*, 4(9): 806-810.
- Seiler, A., 2001: Ecological effects of roads: a review. Introductory research essay, 9: 1-40.
- Seitzinger, S.P., Mayorga, E., Bouwman, A.F., Kroeze, C., Beusen, A.H.W., Billen, G., Van Drecht, G., Dumont, E., Fekete, B.M., Garnier, J. and Harrison, J.A., 2010: Global river nutrient export: A scenario analysis of past and future trends. *Global Biogeochemical Cycles*, 24(4): n/a-n/a.
- Seto, K.C. and Kaufmann, R.K., 2003: Modeling the drivers of urban land use change in the Pearl River Delta, China: integrating remote sensing with socioeconomic data. *Land Economics*, 79(1): 106-121.
- Shandra, J.M., McKinney, L.A., Leckband, C. and London, B., 2010: Debt, structural adjustment, and biodiversity loss: a cross-national analysis of threatened mammals and birds. *Human ecology review*, 17(1): 18-33.
- Shaw, S.D., Brenner, D., Bourakovsky, A., Mahaffey, C.A. and Perkins, C.R., 2005: Polychlorinated biphenyls and chlorinated pesticides in harbor seals (*Phoca vitulina concolor*) from the northwestern Atlantic coast. *Marine Pollution Bulletin*, 50(10): 1069-1084.
- Skalský, R., Tarasovičová, Z., Balkovič, J., Schmid, E., Fuchs, M., Moltchanova, E., Kindermann, G. and Scholtz, P., 2008: GEO-BENE global database for bio-physical modeling v. 1.0. Concepts, methodologies and data. IIASA, The GEO-BENE database report, Laxenburg, Austria.
- Skogen, M.D., Sjøiland, H. and Svendsen, E., 2004: Effects of changing nutrient loads to the North Sea. *Journal of Marine Systems*, 46(1-4): 23-38.
- Smith, V.H., Tilman, G.D. and Nekola, J.C., 1999: Eutrophication: impacts of excess nutrient inputs on freshwater, marine, and terrestrial ecosystems. *Environmental pollution*, 100(1): 179-196.
- Smith, R.J., Muir, R.D.J., Walpole, M.J., Balmford, A. and Leader-Williams, N., 2003: Governance and the loss of biodiversity. *Nature*, 426(6962): 67-70.
- Sodhi, N.S., Koh, L.P., Brook, B.W. and Ng, P.K.L., 2004: Southeast Asian biodiversity: an impending disaster. *Trends in Ecology & Evolution*, 19(12): 654-660.

- Spangenberg, J.H., 2007: Integrated scenarios for assessing biodiversity risks. *Sustainable Development*, 15(6): 343-356.
- Speedy, A.W., 2003: Global production and consumption of animal source foods. *The Journal of Nutrition*, 133(11): 4048S-4053S.
- Stave, J., Oba, G., Nordal, I. and Stenseth, N.C., 2007: Traditional ecological knowledge of a riverine forest in Turkana, Kenya: implications for research and management. *Biodiversity and Conservation*, 16(5): 1471-1489.
- Steffan-Dewenter, I., Kessler, M., Barkmann, J., Bos, M.M., Buchori, D., Erasmi, S., Faust, H., Gerold, G., Glenk, K., Gradstein, S.R. and others, 2007: Tradeoffs between income, biodiversity, and ecosystem functioning during tropical rainforest conversion and agroforestry intensification. *Proceedings of The National Academy of Sciences*, 104(12): 4973-4978.
- Stehfest, E., Bouwman, L., van Vuuren, D.P., den Elzen, M.G.J., Eickhout, B. and Kabat, P., 2009: Climate benefits of changing diet. *Climatic Change*, 95(1-2): 83-102.
- Stone, D., Maxwell, S. and Keating, M., 2001: Bridging research and policy. An International Workshop Funded by the UK Department for International Development Radcliffe House, 16-17 July 2001, Warwick University, 49.
- Sumaila, U.R., Cheung, W.W.L., Lam, V.W.Y., Pauly, D. and Herrick, S., 2011: Climate change impacts on the biophysics and economics of world fisheries. *Nature Climate Change*, 1(9): 449-456.
- Sundt, P., Schulze, P.-E. and Syversen, F., 2014: Sources of microplastic-pollution to the marine environment. Norwegian Environment Agency (Miljødirektoratet), M-321|2015,
- Techera, E.J. and Klein, N., 2011: Fragmented governance: reconciling legal strategies for shark conservation and management. *Marine Policy*, 35(1): 73-78.
- Teuten, E.L., Saquing, J.M., Knappe, D.R.U., Barlaz, M.A., Jonsson, S., Björn, A., Rowland, S.J., Thompson, R.C., Galloway, T.S. and Yamashita, R., 2009: Transport and release of chemicals from plastics to the environment and to wildlife. *Philosophical Transactions of the Royal Society B: Biological Sciences*, 364(1526): 2027-2045.
- Thow, A.M. and Hawkes, C., 2009: The implications of trade liberalization for diet and health: a case study from Central America. *Globalization and Health*, 5(1): 5.
- Tilman, D., Balzer, C., Hill, J. and Befort, B.L., 2011: Global food demand and the sustainable intensification of agriculture. *Proceedings of The National Academy of Sciences*, 108(50): 20260-20264.
- UN, 2015: World Population Prospects: The 2015 Revision, Key Findings and Advance Tables. United Nations, Department of Economic and Social Affairs, Population Division, ESA/P/WP.241,
- UNDP, 2014: Human Development Index. United Nations Development Programme, Geneva.
- UNEP, 2006: Africa Environment Outlook 2: Our Environment, Our Wealth. Division of Early Warning and Assessment, United Nations Environment Programme, Nairobi, Kenya.
- UNEP, 2013: Haiti - Dominican Republic: Environmental challenges in the border zone. Nairobi, Kenya, United Nations Environmental Programme.
- Urban, M.C., 2015: Accelerating extinction risk from climate change. *Science*, 348(6234): 571-573.
- van Asselen, S. and Verburg, P.H., 2013: Land cover change or land-use intensification: simulating land system change with a global-scale land change model. *Global Change Biology*, 19(12): 3648-3667.
- van Delden, H., Seppelt, R., White, R. and Jakeman, A.J., 2011: A methodology for the design and development of integrated models for policy support. *Environmental Modelling & Software*, 26(3): 266-279.
- van der Sluijs, J.P., Amaral-Rogers, V., Belzunces, L.P., van Lexmond, M.B., Bonmatin, J.-M., Chagnon, M., Downs, C.A., Furlan, L., Gibbons, D.W. and Giorio, C., 2015: Conclusions of the Worldwide Integrated Assessment on the risks of neonicotinoids and fipronil to biodiversity and ecosystem functioning. *Environmental Science and Pollution Research*, 22(1): 148-154.
- van Meijl, H., van Rheenen, T., Tabeau, A. and Eickhout, B., 2006: The impact of different policy environments on agricultural land use in Europe. *Agriculture, Ecosystems & Environment*, 114(1): 21-38.
- van Vliet, J., Hurkens, J., White, R. and van Delden, H., 2012: An activity-based cellular automaton model to simulate land-use dynamics. *Environment and Planning B: Planning and Design*, 39(2): 198-212.
- van Vuuren, D.P., Kok, M.T.J., Girod, B., Lucas, P.L. and de Vries, B., 2012: Scenarios in Global Environmental Assessments: Key characteristics and lessons for future use. *Global Environmental Change*, 22(4): 884-895.

- van Vuuren, D.P., Riahi, K., Moss, R., Edmonds, J., Thomson, A., Nakicenovic, N., Kram, T., Berkhout, F., Swart, R., Janetos, A., Rose, S.K. and Arnell, N., 2012: A proposal for a new scenario framework to support research and assessment in different climate research communities. *Global Environmental Change*, 22(1): 21-35.
- van Vuuren, D.P., Edmonds, J., Kainuma, M., Riahi, K., Thomson, A., Hibbard, K., Hurtt, G.C., Kram, T., Krey, V., Lamarque, J.-F., Masui, T., Meinshausen, M., Nakicenovic, N., Smith, S.J. and Rose, S.K., 2011: The representative concentration pathways: an overview. *Climatic Change*, 109(1-2): 5-31.
- Van Wilgen, B.W., Richardson, D.M., Le Maitre, D.C., Marais, C. and Magadlela, D., 2001: The economic consequences of alien plant invasions: Examples of impacts and approaches to sustainable management in South Africa. *Environment, Development and Sustainability*, 3(2): 145-168.
- Verburg, P.H., Eickhout, B. and van Meijl, H., 2008: A multi-scale, multi-model approach for analyzing the future dynamics of European land use. *The Annals of Regional Science*, 42(1): 57-77.
- Verburg, P.H., Tabeau, A. and Hatna, E., 2013: Assessing spatial uncertainties of land allocation using a scenario approach and sensitivity analysis: a study for land use in Europe. *Journal of Environmental Management*, 127: S132-S144.
- Verburg, P., van Asselen, S., van der Zanden, E. and Stehfest, E., 2013: The representation of landscapes in global scale assessments of environmental change. *Landscape Ecology*, 28(6): 1067-1080.
- Verburg, P.H., Dearing, J.A., Dyke, J.G., van der Leeuw, S., Seitzinger, S., Steffen, W. and Syvitski, J., 2015: Methods and approaches to modelling the Anthropocene. *Global Environmental Change*, In Press.
- Vervoort, J., 2013: Shared action on food and environments in East Africa. CGIAR Research Program on Climate Change, Agriculture and Food Security (CCAFS) and Environmental Change Institute, Oxford University Centre for the Environment,
- Videira, N., Antunes, P., Santos, R. and Lopes, R., 2010: A participatory modelling approach to support integrated sustainability assessment processes. *Systems Research and Behavioral Science*, 27(4): 446-460.
- Voinov, A. and Shugart, H.H., 2013: 'Integronsters', integral and integrated modeling. *Environmental Modelling & Software*, 39: 149-158.
- Wagg, C., Bender, S.F., Widmer, F. and van der Heijden, M.G.A., 2014: Soil biodiversity and soil community composition determine ecosystem multifunctionality. *Proceedings of The National Academy of Sciences*, 111(14): 5266-5270.
- Walther, G.-R., Roques, A., Hulme, P.E., Sykes, M.T., Pyšek, P., Kühn, I., Zobel, M., Bacher, S., Botta-Dukát, Z., Bugmann, H. and others, 2009: Alien species in a warmer world: risks and opportunities. *Trends in Ecology & Evolution*, 24(12): 686-693.
- Walz, A., Braendle, J.M., Lang, D.J., Brand, F., Briner, S., Elkin, C., Hirschi, C., Huber, R., Lischke, H. and Schmatz, D.R., 2014: Experience from downscaling IPCC-SRES scenarios to specific national-level focus scenarios for ecosystem service management. *Technological Forecasting and Social Change*, 86: 21-32.
- Westermann, O., Ashby, J. and Pretty, J., 2005: Gender and social capital: The importance of gender differences for the maturity and effectiveness of natural resource management groups. *World development*, 33(11): 1783-1799.
- Willis, K.J. and Bhagwat, S.A., 2009: Biodiversity and Climate Change. *Science*, 326(5954): 806-807.
- Wirsenius, S., Azar, C. and Berndes, G., 2010: How much land is needed for global food production under scenarios of dietary changes and livestock productivity increases in 2030? *Agricultural Systems*, 103(9): 621-638.
- Wolters, V., 2001: Biodiversity of soil animals and its function. *European Journal of Soil Biology*, 37(4): 221-227.
- Wright, S.J., Sanchez-Azofeifa, G.A., Portillo-Quintero, C. and Davies, D., 2007: Poverty and corruption compromise tropical forest reserves. *Ecological Applications*, 17(5): 1259-1266.
- Zhu, Y., Chen, H., Fan, J., Wang, Y., Li, Y., Chen, J., Fan, J., Yang, S., Hu, L. and Leung, H., 2000: Genetic diversity and disease control in rice. *Nature*, 406(6797): 718-722.

Chapter 4 Modelling impacts of drivers on biodiversity and ecosystems

Coordinating Lead Authors:

Lluís Brotons (Spain), Villy Christensen (Canada), N H Ravindranath (India)

Lead Authors:

Mingchang Cao (China), Jung Hwa Chun (The Republic of Korea), Olivier Maury (France), Pablo Luis Peri (Argentina), Vânia Proença (Portugal), Baris Salihoglu (Turkey)

Contributing Authors:

Rajiv K. Chaturvedi (India), Marta Coll, Sarah P. Otto, Ananya S. Rao (India), Nicolas Titeux (Spain)

Review Editors:

Deborah Hemming (United Kingdom), Michael Huston (USA)

Purpose of this chapter: Explores key issues in modelling impacts of changes in direct drivers (from Chapter 3) on biodiversity and ecosystems; and critically reviews major types of models for generating outputs that are either directly relevant to assessment and decision-support activities, or are required as inputs to subsequent modelling of nature's benefits to people (covered in Chapter 5).

Target audience: Aimed mostly at a more technical audience – i.e. scientists and practitioners wanting to identify appropriate biodiversity and ecosystem modelling approaches for particular applications.

Key findings

Models of biodiversity and ecosystem function are critical to our capability to predict and our understanding of responses to environmental change (Section 4.2). Modelling is one way to help policy makers to assess the implications of different drivers on biodiversity and ecosystems, as well as the feedbacks on drivers generated by those impacts (from Chapter 3). Modelling provides tools that can help project future dynamics based on scenarios of direct and indirect drivers. However, the capacity of biodiversity modelling to meet policy-making needs is still affected by the lack of data and knowledge, and by model complexity and uncertainty.

There is a need to match biodiversity and ecosystem function model development to stakeholder and policy needs (Section 4.3.2.1). Biodiversity and ecosystem models heavily rely on assumptions about key processes and input data. There is a need to involve stakeholders with modellers in the representation of these processes and assumptions and in the identification of critical drivers (i.e. outputs from scenarios, Chapter 3), and the biodiversity/ecosystem response variables that need to be addressed. Further, it is important that the underlying context, uncertainties, validity, specificity, and outputs of the models are clearly and transparently interpreted and explored jointly by the modellers and the stakeholders.

Biodiversity and ecosystem modelling heavily depends on our understanding of ecosystem structure, function and process and their adequate representation in models (Section 4.2.1). Both understanding and adequate representation depend on data availability, so there is a need to generate and compile representative data for different biodiversity variables in different ecosystems at multiple locations and different scales. Observation networks, as well as long term monitoring programs are therefore critical to assess the response of ecosystems to drivers of change such as climate change, land use change, exploitation and pollution and inform model development.

Uncertainty in ecosystem dynamics is inherent in ecosystem modelling (Section 4.6). Uncertainty, which is inherently associated with model processes, data limitations and environmental stochasticity, can be accounted for by using multi-model ensembles, quality assurance and quality control, and generation of data from long-term observations. Different models may provide results that should be interpreted within the context of the model assumptions and input data. Biodiversity and ecosystem functioning models currently available provide a range of options to assist policy makers in understanding relationships between drivers and the impacts and to design of efficient policies.

The scientific community has recognised the importance of developing strategies to address the limitations of current models and suitably treat the different sources of uncertainty involved. Such well established guidelines are relevant because assessment of available approaches to model biodiversity and ecosystem responses to environmental changes clearly concludes that there is no single modelling approach (or model category) that can serve all assessment needs and decision-making requirements.

Key recommendations

Efforts should be made to ensure that experts involved in Intergovernmental Platform on Biodiversity and Ecosystem Services (IPBES) deliverables are aware of the important role that models of biodiversity and ecosystem functioning play in formalising the complexity of living systems (Section 4.2). In particular, it is important that experts in IPBES task forces and assessments recognize the complexities linking drivers of environmental change to ecosystem dynamics and acknowledge the value of modelling as a method to formally represent - and therefore simplify - such complexity and as a scientific tool for supporting decision-making. This can be facilitated by the selection of experts for IPBES deliverables who are familiar with the limitations and use of models of biodiversity and ecosystem functioning. In addition, follow-up activities in Deliverable 3c can provide additional guidance to experts in IPBES deliverables - especially the thematic, regional and global assessments - to assist in the interpretation and correct use of biodiversity models.

Encouraging stakeholder participation in scenario and model use as early as possible in assessments would provide substantial benefits for IPBES (Section 4.7). This would maximise the correspondence between the objectives of the assessments and the outputs and limitations of the ecosystem modelling approach to be developed or interpreted. It is important that modellers and stakeholders interact along the different stages of modelling exercises

Scope of this chapter:

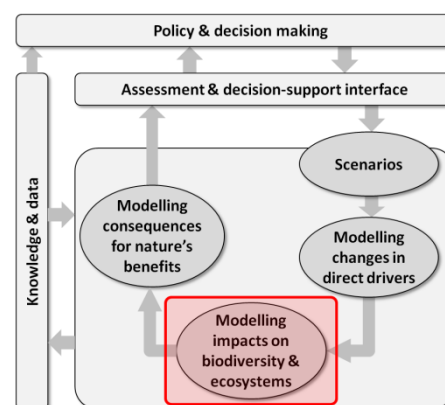

concerning selection of key questions, the context, assumptions, the scale, time-frame, etc. Mechanisms for facilitating this dialog are not yet explicitly laid out in the IPBES Work Programme.

Experts involved in IPBES assessments should critically evaluate the quality of the information used in modelling exercises. The task force on Knowledge, Information and Data, could encourage long-term observations that would improve our understanding of biodiversity and ecological patterns (Section 4.3.2). This will enable models and outputs to be improved and to better fit IPBES objectives. IPBES needs to ensure that a quality chain between data type, model output and suitability for end-use is taken into account in all assessments. Linkage of these components cannot be adequately implemented if data is scarce or low quality, thus leading to constraints in how it feeds into a given decision context (Chapter 8).

The development of consistent protocols is important for IPBES in order to ensure the quality of the use of models and their outputs in assessments (Section 4.3.2.2). Model inter-comparison programmes would encourage increased collaboration among the modelling groups and also with the field ecologists to develop suitable protocols for modelling drivers impacting biodiversity and ecosystem functions. One of the examples of such strategies include the engagement of the scientific community to form model inter-comparison groups, similar to those developed in the context of the Intergovernmental Platform on Climate Change (IPCC) assessments, involving a large number of modelling groups working on biodiversity and ecosystem modelling.

Explicit characterization of uncertainty should be a priority in presentation and use of biodiversity and ecosystem model outputs within IPBES (Section 4.6). Communication of outputs needs to adequately identify uncertainty associated with scenario development (Chapters 2 and 3) and clearly describe and communicate issues directly related to the choice of biodiversity and ecosystem models. To enable robust decision-making and to account for uncertainty in the outcomes of biodiversity models, an integration of multi-model techniques and ensembles of multiple models and scenarios that provide a range of projections could be promoted in assessments. These practices should be encouraged, including by engaging with the scientific community through the task force on Knowledge, Information and Data and through follow-up activities of Deliverable 3c.

The development of guidelines for integrated ecosystem modelling would be very beneficial for IPBES assessments. There is a need for the development of integrated models that can be applied in marine, terrestrial and freshwater ecosystems to assess the impact of drivers and their feedbacks on biodiversity and ecosystems. These integrated models should consider both biophysical and socio-economic drivers and their feedbacks at scales relevant to ecological processes underlying biodiversity changes and to decision-making processes.

4.1 Introduction and conceptual framework

Biodiversity and ecosystem dynamics are inherently complex and so is their response to environmental drivers, including natural and anthropogenic drivers. Models are powerful tools to address complex systems, they can be used to assess and predict the impacts of drivers on biodiversity and ecosystems and hence the impacts on ecosystem services and human well-being. This chapter focuses on the approaches and methods currently available to explicitly link environmental changes with biodiversity and ecosystem responses, from changes in population size to community composition and structure to biogeochemistry fluxes. The aim is to identify the range of tools available to unravel patterns and mechanisms of biodiversity and ecosystem change, and incorporate this knowledge in models allowing the projection of the future state of biodiversity and ecosystems in particular decision-making and management contexts (see Chapter 2).

The chapter first provides an introduction to the context in which biodiversity and ecosystem models are to be developed, including the relevant aspects of biodiversity response to drivers and a typology of the main modelling approaches (Section 4.2). Next, an overview of available modelling approaches relevant to IPBES, at different levels of biological organization, is provided (Section 4.3). It comprises an explanation of model structure, scope of application and illustrating examples. To further guide the use of the most appropriate models, this section includes a critical analysis of the different modelling tools available, of model limitations, and of existing information and capacity-building needs.

Sections 4.4 - 4.6 cover major issues in biodiversity modelling, namely, modelling biodiversity feedbacks into environmental drivers, balancing model complexity and applicability, and addressing uncertainty. The issues associated with the sources of uncertainty in model projections are of utmost importance in the context of biodiversity projections for IPBES, and we describe this topic in depth in the context of biodiversity and ecosystem modelling. We finally identify the major challenges for biodiversity projections in the context of the IPBES programme, and highlight major avenues for policy makers at a range of administrative scales.

This chapter is directly linked to Chapter 3 (scenarios and models of indirect and direct drivers) and to Chapter 5 (modelling nature's benefits to people). The models discussed in this chapter provide a means of translating scenarios of drivers, as described in Chapter 3, into expected impacts on biodiversity and ecosystems. In turn, outputs (i.e. projections) from the models described in this chapter can serve as inputs to modelling change in nature's benefits to people (including ecosystem services), as discussed in Chapter 5. Moreover, because the engagement of stakeholders

in biodiversity modelling exercises and the effective communication of results to policy makers are fundamental for the successful use of models, there is a two-way link between the present chapter and Chapter 2.

The main external input when modelling biodiversity response to environmental change or pressures is the change in the state of drivers directly affecting biodiversity and ecosystems. In this chapter, we consider modelling approaches that assess the impacts of direct drivers of environmental change as identified by the Millennium Ecosystem Assessment (MA, 2005b): habitat change, climate change, overexploitation, pollution and invasive species. Scenario development and modelling methods for projecting future changes in direct drivers, to be used as inputs in biodiversity and ecosystems models, are described in detail in Chapter 3.

As for connection and potential overlap with Chapter 5, it is important to note the multiple roles of biodiversity and ecosystems in the conceptual chain linking direct drivers to nature's benefits to people. Specifically, biodiversity may either regulate the ecosystem processes that generate final ecosystem services, or itself constitute a final ecosystem service, or even provide a good that is directly enjoyed by people (Mace et al., 2012; Oliver et al., 2015). In the first case, biodiversity attributes affect the development and maintenance of ecosystem processes (Cardinale et al., 2012), such as nutrient cycling (Handa et al., 2014), primary productivity (Cardinale et al., 2007) or water infiltration (Eldridge and Freudenberger, 2005), which in turn give rise to final ecosystem services. In the second case, biodiversity elements are themselves material outputs, with direct use value, such as medicinal plants or fish, but which require human capital inputs (e.g., labour, transport) before being enjoyed by society. Finally, biodiversity elements may themselves be viewed as a good if directly enjoyed by people without any additional input, which is the case with aesthetic enjoyment of nature, ecotourism, etc. Therefore, outputs from biodiversity models (including future projections) can be used as inputs in ecosystem services models, or provide direct information on ecosystem services and goods, such as data on the distribution and abundance of charismatic species. It is worth noting that often ecosystem services models implicitly (i.e. by simplification of biodiversity components and ecosystem functions using land use or land cover surrogate information) or explicitly include biodiversity or ecosystem function sub-modules. A compilation of relevant cases will be treated in further detail in Chapter 5. Moreover, although biotic and abiotic ecosystem components interact and are both essential to ecosystem functioning and to model ecosystem services, in particular regulating services, the focus of this chapter will be on the biotic components, represented by 'Nature' in the IPBES conceptual framework (see Figure 1.2 in Chapter 1).

In accordance with the overall aim of Deliverable 3c to inform and guide other IPBES deliverables in the use of scenarios and models for biodiversity and ecosystem services, this chapter provides relevant information on:

- Modelling methodologies available for the Catalogue of Policy Tools for assessing the response of biodiversity and ecosystems to direct drivers (Deliverable 4c);
- Available modelling methodologies to evaluate scenarios of sustainable use of biodiversity and to assess responses to drivers of land degradation and to invasive species (Deliverable 3b);
- Caveats and good practices for assessments regarding the use of available data in modelling approaches and the use of modelling outputs in literature reviews and in meta-analyses (Deliverables 2b, 2c, 3b);
- Capacity-building needs regarding the use of modelling approaches in decision-making processes and on the engagement of stakeholders in modelling processes (Deliverables 1a, 2b);
- Current knowledge gaps, data needs and future research recommendations to improve models predictability and scope of application (Deliverable 1d)
- Involvement of Indigenous and Local Knowledge in model development, testing and application (Deliverable 1c).

4.2 Structure and components of biodiversity and ecosystem models

Scientists and stakeholders supporting decision-making processes are always faced with the challenge of selecting key processes and drivers leading to relevant impacts on their study object (Guisan et al., 2013), and this is the topic of the present chapter. Decisions on how and what to include explicitly in the modelling process, and what can be simplified or ignored, are crucial, as they will impact model outcomes. The role of biodiversity as a regulator of ecosystem processes or as a material output (either a final service or a good), defines the variables of interest when assessing and projecting the impacts of direct drivers. For instance, community data such as functional or species diversity (Cardinale et al., 2007; Mace et al., 2012) or habitat structure (Eldridge and Freudenberger, 2005) may be particularly important to assess the impact of drivers when biodiversity has a regulatory role, while population data, such as species distribution (Gaikwad et al., 2011), or population structure (Berkeley et al., 2004) would be more appropriate when biodiversity elements have a direct use value. It is also worth noting that overall there is a positive relationship between biodiversity attributes and ecosystem services (Harrison et al., 2014).

The acknowledgement of the different roles of biodiversity follows an anthropocentric perspective that has ecosystem services, the material and non-material benefits generated by nature, as its main end. In parallel to utilitarian values,

biodiversity has its own intrinsic value, which is independent of human demand or appreciation and which is difficult or impossible to quantify through modelling, yet its existence value or evolutionary value may serve to maintain life.

Biodiversity models, as for other mathematical models in environmental sciences, consist of a set of components, namely, state variables, external variables, mathematical equations, and parameters (Jørgensen and Bendoricchio, 2001; Smith and Smith, 2007). Predictions of ecological responses to environmental changes should start with the specification of the major model conceptual components and the critical relationships between them. In the description of any model of this type, the following components should be identified:

1. **Elements describing the ecosystem characteristics.** These are the target state variables used to describe the biophysical components of interest, such as biomass, species richness, functional diversity, or habitat structure (see Figure 4.1). State variables should be included based on their ability to serve as indicators of system state, their sensitivity to pressures, and the stability of their response pattern, but the consideration of available vs. ideal data often calls for a pragmatic approach given the costs and feasibility of data collection.
2. **Environmental and biotic drivers.** The spatial or temporal dynamics of these model components have a direct or indirect effect on the state variables. In the context of environmental change, changes in the value of environmental (e.g., climate change) and biotic drivers will affect the value of the state variables (e.g., changes in species distribution).
3. **Ecosystem/ecological processes.** These model components allow the description of the changes in the stock and/or flow of materials or the interactions among organisms and with their abiotic environment (Mace et al., 2012). Processes are relevant in determining changes in the biological component (e.g., changes in species distribution after colonization and extinction dynamics).

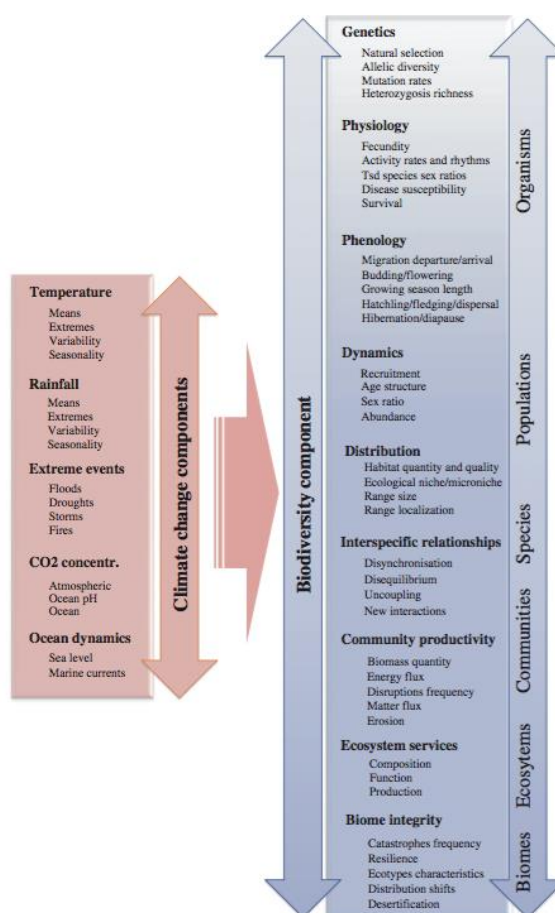

Figure 4.1: Summary of biodiversity state variables and processes affected at different organizational levels by different components of climate change. (Source: Bellard et al., 2012).

Impact of drivers on biological processes is key in determining the nature of the model choice and the inclusion of multidisciplinary expertise in the model building process (Guisan et al., 2013). In the context of environmental change, the effect of environmental pressures on state variables can be direct (e.g., loss of tree cover after deforestation, changes in climate conditions) or mediated by biophysical processes (e.g., ocean acidification and warming affecting coral recruitment and growth, and hence coral abundance and reef structure). In addition, processes also mediate interactions among state variables (e.g., biotic interactions, trophic cascades).

Using community structure as an example, the processes and scales that are important for modelling are illustrated in Figure 4.2, which shows how ‘filters’ select species from a global pool to obtain realized local communities (Thuiller et al., 2013). In other words, and in a context of biodiversity response to change, drivers (input data) create or change geographic or niche filters, thus leading to changes in community composition (output data). The filters (ecological processes involved) include biogeographic and environmental aspects of the real world, and are represented as components in biodiversity models. Species response to direct drivers (box a) is mediated by dispersal and niche filters through a series of processes (box b), which may or may not be explicitly considered in biodiversity models.

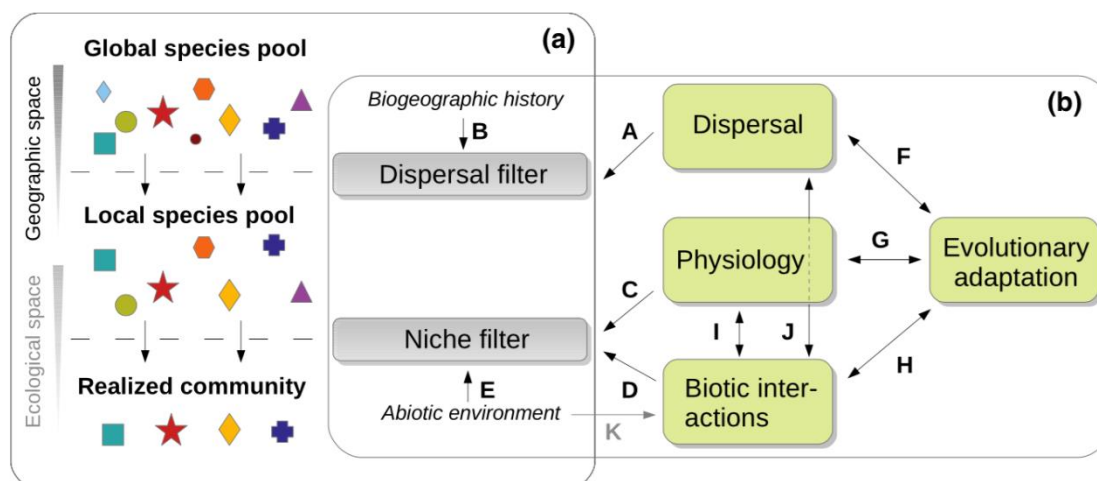

Figure 4.2: (a) Conceptual diagram of how dispersal and niche ‘filters’ select species from pools at different scales, geographically and ecologically. (b) Main processes that impact the filtering process, directly or indirectly. (Source: Thuiller et al., 2013).

4.2.1 Describing ecosystems in models: biological levels for modelling

Biodiversity and ecosystem responses to environmental change can assume many forms as a consequence of its inherent complexity; a way of addressing this diversity is to reduce it to a few meaningful dimensions. Biodiversity and ecosystem variables can be arranged along dimensions representing key aspects of biodiversity complexity, that is, biological organization levels (species, populations, ecosystems, etc.) and biodiversity attributes (composition, structure, and function). These two dimensions define a conceptual space that can be useful for identifying relevant response variables (see Table 4.1). More specifically, composition and structural elements, such as species richness or biomass, correspond to state variables, and functional elements, such as primary productivity, herbivory, or competition, to processes. Composition and structure emerge from processes, but also affect them (Dale and Beyeler, 2001).

From an ecological perspective, composition and structure variables describe the structural elements of ecosystems, while processes describe the fluxes of energy and matter, and the interactions within and between organization levels.

Ecosystems are open systems. They harness solar energy and transfer it through their various structural elements and organization levels, via different biological and ecological processes. At the biosphere level, water and nutrients, such as carbon, nitrogen and phosphorus, are key structural elements of all living components, and key abiotic components of ecosystems. Their flux across the Earth system is described by the biogeochemical cycles. This flux of energy permits life on Earth and fuels the ecological functions that are useful for societies (i.e. ecosystem services). To model the dynamics of biodiversity, it is important that major ecological processes involved in the transfer of energy through ecosystems are taken into account (Mokany et al., 2015). These include production, consumption, respiration, and recycling. Other processes such as regulation and evolution are critical to the maintenance of biodiversity and the resilience of ecosystems over time.

Primary production and respiration are major ecological processes, occurring at the organism level but affecting population dynamics and community structure. Organic matter from primary production forms the basis of all life on Earth. Numerous factors such as light, availability of inorganic nutrients, water and temperature influence primary production. Respiration, which encompasses all the living processes using oxygen, is at the core of metabolism. While occurring at the organism level, both processes can be considered at every level of organization. Primary productivity for instance is often used as an indicator of ecosystem functioning and modelled at the level of communities or ecosystems to assess the impacts of land use change, climate change and management practices on vegetation. Regarding respiration, at the organism level, respiration processes are influenced by many factors including the

species considered (body-size scaling rules imply that many metabolic processes vary with the maximum size that a species can reach, (Kearney et al., 2010), the size of individuals, their condition, the availability of food, oxygen and temperature. At the population level, respiration integrates the metabolism of all individuals. It is therefore highly dependent of the size- and state-structure of the population. At the community level, respiration integrates the metabolism of all populations and is therefore controlled by their relative abundance and the structure of the community. Consumption and recycling are main processes associated with trophic interactions, thus being modelled at the community and ecosystem levels (Sarmiento and Gruber, 2006). Consumption constitutes a major process of ecosystem dynamics that transfers solar energy along food chains, from primary producers up to top predators. Trophic interactions are influenced by various factors, including by spatial-temporal co-occurrence of grazers/predators and their food/prey, which is often constrained by environmental features.

In addition to the metabolic processes described above, processes related to biodiversity responses to environmental changes can be broadly divided into population and community responses (Lavergne et al., 2010). Firstly, mechanisms related to the ecology of the species populations, including dispersal, plasticity, and population dynamics. Those processes are primarily determined by biological traits expressing the capability of the target species to deal with environmental variability in space and time (e.g., Thuiller et al., 2013; Hanski et al., 2013). Secondly, species interactions can restrict or expand the set of places that the species is able to inhabit (Davis et al., 1998). Competition, facilitation or trophic relationships are site and species-specific and account for a great deal of variability in a species capability to survive in a given environment.

Table 4.1

Examples of biological levels for modelling (compositional, structural, and functional biodiversity variables, from (Noss, 1990; Dale and Beyeler, 2001) selected to represent levels of biodiversity that warrant attention in environmental monitoring and assessment programs.

<i>Level</i>	<i>Composition</i>	<i>Structure</i>	<i>Function</i>
Individuals	Genes	Genetic structure	Genetic processes, metabolism
Populations	Presence, abundance, cover, biomass, density	Population structure, range, morphological variability	Demography, dispersion, phenology
Communities	Species richness, evenness and diversity, similarity	Canopy structure, habitat structure,	Species interactions (herbivory, predation, competition, parasitism), decomposition
Ecosystems	Habitat richness	Spatial heterogeneity, fragmentation, connectivity	Ecosystem processes (hydrologic processes, geomorphic processes), disturbances

4.2.2 Introducing drivers of environmental change

The world has experienced global environmental change due to human activities, and this has encouraged research on scenarios and models to study the new challenges that biodiversity is exposed to (Pereira et al., 2010). Assessments of links between these drivers and biodiversity responses are central to IPBES. Change in biodiversity is determined both by changes in the environment and by the ecological and physiological processes contributing to the dynamics of these ecological systems (Lavergne et al., 2010). Thus biodiversity change may be either related to changes in the environment itself, to the biological processes acting within ecosystems or, more frequently, to the combination of both (Leung et al., 2012). It is therefore important to distinguish between changes caused by anthropogenic drivers and changes emerging from the natural dynamics of ecological systems. This is particularly important because although biodiversity and ecosystem services experience change due to natural causes, anthropogenic drivers increasingly dominate current environmental changes.

Following the IPBES conceptual framework, natural and anthropogenic drivers directly affect biodiversity. Both natural and anthropogenic direct drivers of impact on ecosystem processes explicitly cause measurable changes in ecosystem properties.

Natural direct drivers emerge from natural biophysical and geophysical processes, while anthropogenic drivers result from the trajectory and interactions of socio-economic drivers (indirect drivers).

Biodiversity models use variables describing properties of direct drivers as inputs to predict their impact on biodiversity variables. Historically, the most important impact on biodiversity has been through land use change for terrestrial ecosystems (Pereira et al., 2012), and through resource exploitation for marine ecosystems (MA, 2005a). Freshwater ecosystems have been strongly impacted by a range of factors, including notably habitat modifications, invasive species, and pollution. Climate and land use changes have probably now reached a similar level of pressure on ecosystems, but during the last three centuries land use change has exposed 1.5 times as many landscapes to significant modifications as climate change (Ostberg et al., 2015).

Human impacts on the global environment are operating at a range of rates and spatial scales. Scaling issues are particularly important when assessing impacts on biodiversity and ecosystem services because drivers have different impacts at different scales. For example, while climate change is a driver that acts at the global scale, habitat modification has an impact on biodiversity and ecosystems services at regional and local scales. The consequences of habitat modification have been significant for many aspects of local, regional, and global environments, including climate, atmospheric composition, species composition and interactions, soil condition, and water and sediment flows. However, global-scale assessments typically mask critical sub-global variations thus underestimating the effects drivers acting at local scales. Local and regional case studies can provide the spatial and temporal resolution required to identify and account for major environmental sources of variations in cause-to-cover relationships and the consequence on biodiversity. Single-factor explanations, at the macro or the micro scale, have not proven adequate (Bellard et al., 2015). Many models assessing the impact of environmental drivers on terrestrial ecosystems and biodiversity elements, including those dealing with climate and trace-gas dynamics, require projections of land-cover change as inputs. In this context, Loreau et al. (2003) highlighted that knowledge of spatial processes across ecosystems at the local scale is critical to predict the effects of landscape changes on both biodiversity and ecosystem functioning and services.

4.2.3 Dealing with processes: the model continuum from correlative to process-based approaches

There are a wide variety of ecological models that can be used for assessing impacts of direct drivers on biodiversity and ecosystem functioning. They can be categorized based on their complexity and degree of formalization from expert-based systems, which rely on experience including in the form of local knowledge, to complex integrated ecosystem models.

Quantitative models are generally classified in two broad categories: correlative and process-based models (e.g., Pereira et al., 2010; Dormann et al., 2012). To distinguish between these model types, we follow the model definitions of Dormann et al. (2012) where correlative models are characterized by having parameters that do not have predefined ecological meaning, and for which processes are implicit. Process-based models, in contrast, use explicitly stated mechanisms, and parameters have a clear ecological interpretation, defined beforehand.

In the literature, the terms process-based models and mechanistic models are often used as synonyms. Here, we use the term process-based for any model type with explicit implementation of ecological processes in the model implementation (i.e. encompassing both process-based and purely mechanistic models), and we reserve the mechanistic category for the subset of models that are developed on ecological theory only and which do not use correlative approaches at all for parameterization. The primary difference along this modelling axis is the inductive vs deductive approach to processing information. The basic advantage of correlative models, also termed as phenomenological or statistical models, is that there is no need for a fundamental understanding of the ecosystem and relationships between system elements, as these are derived inductively from empirical observations. With process-based models there is a deductive process involved where the process is determined, relationship derived, quantified and explicitly modelled (Jørgensen and Bendoricchio, 2001). At the other end of the formalization gradient, pure mechanistic models also termed as theoretical models are axiomatic constructions (Gallien et al., 2010). Like in theoretical physics, they use the hypothetico-deductive scientific method, starting from hypothesis (the axioms) to deduce predictions that can be tested empirically, to falsify or conversely to corroborate the hypothesis made (but never to prove it or ‘validate’ it).

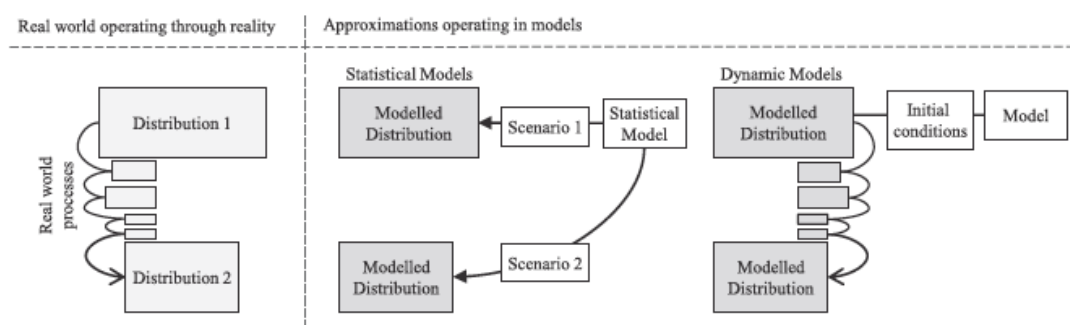

Figure 4.3: Schematic representation of the relationship between two observations of a species distribution in the ‘real world’, ‘correlative (statistical) models’ and ‘dynamic, process-based models’. (Source: McInerney and Etienne, 2012).

To illustrate how models are both abstractions from and representations of reality, Figure 4.3 shows how real world processes change an entity (here a distribution) from one state to another. In a correlative model, the two distribution states are modelled with two alternative scenarios (e.g., before and after a forest fire). In the process-based dynamic model, the model builds on a set of initial conditions, to derive a modelled distribution, which then is altered through specified processes that aim to replicate the real world phenomena in order to predict the second modelled distribution. It must be noted that the real world processes are often unknown and indeed never can be fully known or

emulated. Process-based modelling therefore cannot be expected to fully replicate the real world situation, but it may provide a useful approximation (McInerny and Etienne, 2012).

In practice, the categorization of ecological models is rarely as clear-cut as that depicted in Figure 4.3, but rather tend to fall along a continuum from correlative to process-based, depending on available data and parameters, purpose, and model philosophy. This model continuum, however, forms the basis for the presentation here, which also describes a spectrum for how the broad model types rely on empirical data vs. ecological knowledge.

Whether modelling is based on correlative or process-based approaches (or any intermediate type for that matter) there are a number of issues that should be considered as part of the model building process (Table 4.2). For instance, statistical assumptions about error structure and unbiased sampling apply to both of the broad types of modelling approaches. The same is not true regarding the assumption that species are in equilibrium with their environment, which applies only to correlative models, at the risk of losing predictive ability.

4.2.3.1 Expert-based systems

The most common approach for evaluating impacts of alternative management procedures related to predictions and decision support is often based on information provided by experts (Cuddington et al., 2013). An expert is defined here as someone who has achieved high knowledge on a subject through her/his life experience (Kuhnert et al., 2010), and the expert may be a person with local knowledge or a scientist. It is assumed, that the expert is a reliable source of information in a specific domain, though it appears that experts tend to be far more confident in their opinions than is warranted (Burgman, 2005).

Eliciting expert information usually involves dealing with multiple expert judgements, with different sources of biases and uncertainty around expert estimates (Martin et al., 2012). For instance, expertise may vary geographically, with relevant information restricted to the region of interest of the experts (Murray et al., 2009). Structuring how multiple expert opinions are used, e.g., through a Delphi approach (MacMillan and Marshall, 2006), can make the modelling much more rigorous and less likely to result in arbitrary predictions (Sutherland, 2006).

The expert-based approach typically includes five steps: considering how the information will be used, deciding what to elicit, designing the process for the elicitation, the actual conduction of the elicitation, and finally translating the elicited information into quantitative statements that can either be used directly or used in an integrative or participatory modelling approach (Martin et al., 2012).

Expert knowledge-based species-habitat relationships are used extensively to guide conservation planning, particularly when data are scarce (Iglecia et al., 2012). Expert knowledge is quite commonly utilized in conservation science (Janssen et al., 2010; Aizpurua et al., 2015), and has frequently been incorporated in aquatic habitat suitability modelling to link environmental conditions to the quantitative habitat suitability of aquatic species (Mouton et al., 2009).

Table 4.2

Summary of aspects to be considered during the model building process, From Dormann et al. (2012).

Topic	Relevant issues
Assumptions	Error structure, structure of functional relationships, relevant processes/predictors, equilibrium with environment
Information required	Data on distribution, populations, environments, etc., environmental data, ecological and biological knowledge
Determination of model structure	Variable selection, alternative functional relationships, submodels
Verification	Technical correctness, model diagnostics
Validation	Cross-validation, external validation, parameter validation, sensitivity, specificity
Sources of uncertainty in model predictions	Input data, model misspecification, regression dilution, stochasticity
Equifinality	Over-parameterization, collinearity, non-identifiability
Extrapolation	Model domain, (micro-)evolution, stationarity of limiting factors and interactions, phenotypic plasticity
When to stop: accuracy versus complexity	Deployment time, re-parameterization, sensitivity analysis
Communicability and model transparency	Documentation, open source code/software
Knowledge potentially gleaned from the model	Surprise, emergence
Common errors and misuses	Lack of uncertainty analysis, use beyond purpose, overconfidence in communication

4.2.3.1.1 Indigenous and local knowledge (ILK)

Indigenous people with collective knowledge of the land, sky and sea, are excellent observers and interpreters of changes in the environment. Their knowledge may offer valuable insights, complementing scientific data with chronological and landscape-specific precision and detail that is critical for verifying models and evaluating scenarios developed by scientists at much broader spatial and temporal scale.

Moreover, ILK provides a crucial foundation for community-based actions that sustain resilience of social-ecological systems at the interconnected local, regional and global scales (Raygorodetsky, 2011). Indigenous and local observations and interpretations of ecological phenomena at a much finer scale have considerable temporal depth and highlight elements that may be marginal or even new to scientists.

ILK can potentially supplement other scientific data in modelling as input to the model as well as interpretation and understanding of the outputs of model runs. Traditional or indigenous knowledge is a result of a long series of observations transmitted from generation to generation (Berkes et al., 1995). Such ‘diachronic’ observations (i.e. observations over time) can be of great value and complement the ‘synchronic’ observations (i.e. observations made at the same time, but at different locations) that are often used for model construction and testing (Gadgil et al., 1993). Knowledge holders have not only developed a stake in conserving biodiversity, but also in understanding the complexities and interrelations amongst the varied entities that an ecosystem encompasses (Slobodkin, 1961). Modelling for biodiversity conservation and ecosystem services can benefit significantly from application of ILK, and may fill gaps in biodiversity modelling (Thaman et al., 2013; WWF, 2013).

ILK thus has the potential to contribute to global environmental assessments, posing the challenge of how different scales can be integrated, and how different knowledge systems can be connected to complement each other. One of the approaches of IPBES, the ‘Multiple Evidence Base approach’ was developed at the Stockholm Resilience Centre as a conceptual framework for connecting diverse knowledge systems (Tengö et al., 2013).

Integration of ILK in research techniques such as modelling and remote sensing can provide a robust contribution to informed decision-making. An example is animal herd management in the Arctic, where remote satellite sensing, meteorology and modelling are complemented with the indigenous knowledge of Sami and Nenets reindeer herders to co-produce datasets. The indigenous observers are able to make sense of complex changes in the environment through qualitative assessment of many factors, complementing quantitative assessment of variables made by scientists (Magga et al., 2011). Case studies from Canada and New Zealand also provide evidence that a combination of traditional ecological knowledge and science to understand and predict population responses can greatly assist co-management for sustainable customary wildlife harvests by indigenous peoples (Moller et al., 2004).

4.2.3.2 Correlative models

Correlative models are generally easy to apply, and they do not require extensive knowledge of underlying processes, but instead use statistical methods to establish direct relationships between environmental variables and biodiversity data, such as species richness, abundance or distribution (Morin and Lechowicz, 2008). These models produce information on biodiversity patterns and responses to drivers based on empirical observations, and do not attempt to explain the mechanisms underlying those patterns and responses (Rahbek et al., 2007). When using the correlative modelling approach it is recognized that there are clear limitations to ecological knowledge for model development, and often the focus is on ensuring a pragmatic model implementation that will capture current existing ecological patterns, and this often provides good, if narrow, projections (Araújo and Pearson, 2005; Elith and Leathwick, 2009).

Correlative models are frequently used to assess the impacts of human activities on biodiversity, forecast future impacts of environmental changes, support human productive activities (e.g., enhance agricultural production) and conservation actions (e.g., identify sites for translocations and reintroductions, predict the location of rare and endangered species), understand species’ ecological requirements, among other uses (Peterson, 2006; de Souza Muñoz et al., 2011). Correlative models have the advantage of being tractable and easy to interpret, and permit predictability of phenomena that depend on differences between components – e.g., the invasive potential of a species depends on the difference between potential and actual distributional areas (Peterson, 2006).

Correlative models can be applied at all spatial scales after careful assessment of relevant environmental predictors and response variables relevant to the question addressed (Elith and Leathwick, 2009; Guillera Arroita et al., 2015). For instance, the effect of climate variables is better assessed at large spatial extents, such as regions, and coarse resolution data may be acceptable, whereas the effect of land use or soil nutrients requires fine resolution data, to cover fine-scale variations, and is usually modelled at smaller extents, such as landscapes. When the selected environmental predictors act at different scales, hierarchical models with nested sub-models can be used (Elith and Leathwick, 2009). Regarding temporal scales, correlative models are often static (i.e., assume that the species-environment relationships do not change over time) failing to capture species or community dynamics, such as species dispersal. Nevertheless, temporal predictors, such as variability of food resources, may be added to models to capture variation in the state of biodiversity variables.

Correlative models should be used carefully when extrapolating biological descriptors to new spatial areas and time frames (i.e. hind-casting and forecasting applications). This is due to the possibility that conditions associated with training data (i.e., the data used to fit the model) may not remain constant over time (Elith and Leathwick, 2009; Araújo and Peterson, 2012) or may be inadequate to represent the conditions found outside their area of distribution. Moreover, correlative models are still data demanding, requiring robust datasets. However, because the data required by correlative models are often available across a range of scales, and because the models can implicitly capture many complex ecological responses, Elith et al. (2010) anticipate continued use of correlative models for biodiversity projections.

4.2.3.3 Process-based models

Process-based models are generally more complex to develop than correlative models, as they require more knowledge of the processes that shape biodiversity patterns, including an explicit consideration of selecting which processes to include. These models nevertheless allow a more explicit representation than correlative approaches of ecological processes mediating biodiversity and ecosystem responses to environmental drivers. As they tend to build on a formal framework with (varying levels) of theoretical underpinning, they also offer more capability to explain why biodiversity patterns occur, rather than just demonstrating that they do. The gold standard for modelling, however, frequently includes the degree to which models can be used for predictive purposes, and while this is an area where process-based models may have an advantage over correlative models, it should also be acknowledged that the capabilities of process-based models with regard to predicting impact of anthropogenic impacts on biodiversity and ecosystems are uncertain and under continuous development. In response to climate change, species may change their climatic niches along three non-exclusive axes: time (e.g., phenology), space (e.g., range) and self (e.g., physiology) as described by Bellard et al. (2012). Of these, especially the physiological axis calls for capacity to handle evolutionary adaptations (see more detail in Section 4.3.1.1). It is also of importance that data availability as a rule places limits on how reliably models can be parameterized.

One example of approaches used to overcome the limitations of correlative methods is the use of Dynamic Energy Budget theory (e.g., Kooijman, 2009). This is a good example of mechanistic theory aiming at capturing the quantitative aspects of metabolism at the organism level from a small set of key assumptions (Sousa et al., 2008). The Dynamic Energy Budget theory allows accounting for environmental variability effects on organisms through food and temperature changes. It captures the diversity of all possible living forms on earth in a single mechanistic framework. This allows representing the energetics and major life history traits of all possible species in a community with the same set of unspecific taxa-dependent Dynamic Energy Budget parameters.

Overall, process-based models are limited by the number of processes that are explicitly included, the sensitivity of the system dynamics to the mathematical form used to represent the process, the sensitivity to the data used to estimate the parameters, and the limited capacity to predict beyond the range of observed conditions. Despite the wide use of process-based ecosystem models in biology and ecology they, as do all other model developments, suffer from fundamental and practical limitations.

Various strategies and approaches for process formalisation can be distinguished amongst the available process-based models:

Box models. This is the simplest and most developed category. It describes ecosystem dynamics using a set of state variables (e.g., fish biomass) that are connected together by fluxes (e.g., consumption, predation) based on given functional responses that are either pre-defined (Holling, 1959) or emergent properties (Ahrens et al., 2012). The most common use of this type of models is to simulate mass balances and energy fluxes at the scale of the system represented, and this is one of their main advantages. The counterpart is that they tend to use highly aggregated representations of state variables (e.g., by lumping all fish species at a trophic level together) and therefore neglect phenomena such as the importance of size in controlling metabolism, predator-prey interactions, and life history omnivory (i.e. diet changes when organisms grow).

Age/stage/size-structured models. These models are box models that are structured along a dimension that is assumed to be functionally important. They explicitly account for some processes of metabolism such as growth, reproduction and the age-dependence of respiration. Age/stage-structured models are widely used for fisheries management (see Hilborn and Walters, 1992) as well as for food web models (e.g., Walters et al., 2010). Size-structured models emphasize the impact of size as a structuring element in ecosystems. In marine and freshwater ecosystems, size is usually a good predictor of trophic level at the community level (Jennings et al., 2001) because many predators are size selective leading to this biological trait to exert a strong influence on predation and metabolism. Size-based models are easier to parameterize than functional group or age/stage-structured food-web models, though in particular applications there may be more interest for species than for size *per se*. Size-structured models can, however, be constructed with explicit species considerations to make them more suitable to address questions of direct relevance for biodiversity research (Shin and Cury, 2001; Blanchard et al., 2014).

4.2.3.4 Hybrid models: combining correlative and process-based modelling

Hybrid models combine correlative and process-based modelling approaches (Schurr et al., 2012) in order to represent complex, integrated systems with a focus on biophysical as well as human components (Parrott, 2011). Such models tend to be highly data driven, they help build understanding of important factors and to synthesize knowledge, and they provide a structural link between data sources and decision support systems. Developments of hybrid models take a pathway where some of the ecological processes defining the ecological system under study (e.g., the realized niche) are modelled explicitly (i.e. process-based), while others are based on correlative niche modelling (Thuiller et al., 2013). Hybrid approaches derive from the interest to balance realism and flexibility in model building with limited knowledge, but this approach also comes with important challenges.

The way different models are integrated into hybrid approaches often is a difficult issue. Gallien et al. (2010) indicate that one of the current limitations of these hybrid approaches is the form and strength of the relationship between habitat suitability and demographic parameters. Changes in habitat suitability are normally integrated with population processes by limiting carrying capacity. Furthermore, how ecological processes (e.g., growth, dispersal, and thermal tolerance) respond to environmental changes is unclear, and is often assumed to be unimodal or linear. Nonlinear functional response could make the model more complex.

Broadly speaking, mechanisms determining ecosystem dynamics can be related to the ecology of species, species interactions, and evolutionary processes (Lavergne et al., 2010). Any biological process of interest should have an explicit link with the components formulated in the model. However, this link does not need to be one-to-one (Lurgi et al., 2015). The implementation of these processes in the model may be carried out in a wide variety of ways spanning a broad range of complexities from cellular automata (Iverson and Prasad, 2001), metapopulation models (e.g., Wilson et al., 2009), structured metapopulation models (Akçakaya et al., 2004) to spatially-explicit population models (e.g., Cabral and Schurr, 2010), individual-based models (e.g., Grimm et al., 2005), trophic models (e.g., Albouy et al., 2014) and reaction-diffusion models (e.g., Wickle, 2003; Hui et al., 2010). For example, the recently introduced ‘dynamic range modelling’ framework (Pagel and Schurr, 2012) based on a Bayesian approach overcomes several of these limitations: it uses species distribution data and time series of species abundance to statistically estimate both distribution dynamics and the underlying response of demographic rates to the environment. This approach is particularly relevant when dispersal limitation or source-sink dynamics cause disequilibrium between species distributions and environmental conditions (Pulliam, 2000).

The Dynamic Bioclimate Envelope Model developed by Cheung et al. (2008b) simulates changes in the relative abundance of marine species through changes in population growth, mortality, larval dispersal and adult movement following the shifting of the bioclimate envelopes induced by changes of climatic variables. The model does not account for species interactions and potential food web changes, which however is considered in a combined food web and habitat capacity model (Christensen et al., 2014). Dynamic bioclimatic envelope models are also being developed to account for effects of ocean biogeochemistry such as oxygen level and pH on the eco-physiology and distribution of marine fish (Stock et al., 2011). Models with emergent dynamics may also include species interactions (e.g., Albert et al. 2008), or abiotic processes included via feedbacks (e.g., wildfires vs. vegetation growth; Grigulis et al. 2005).

4.3 Available approaches to modelling the impact of drivers on biodiversity and ecosystem functioning

4.3.1 Modelling approaches addressing biological levels of special relevance for IPBES

4.3.1.1 Individual-level models and evolutionary adaptation

Populations are not static, they evolve. As a consequence, species may be able to adapt to conditions different from those previously experienced (Hoffmann and Sgrò, 2011). As introduced in Figure 4.2, evolution can alter dispersal patterns, physiology, and biotic interactions (Thuiller et al., 2013), and this poses a clear problem for predictive modelling at all levels, from genes to ecosystems: how to make predictions that go beyond current conditions?

There has been considerable research aimed at addressing this question, notably theoretical models that explicitly account for biological processes such as mutation, dispersal, and interactions within and among species (e.g., mating, competition) (Bürger, 2000). Such models can account for environmental change and allow projections about future scenarios, beyond the range of what is currently observed. They also provide a means of assessing the robustness of predictions across uncertain parameters and processes.

Short-term evolutionary projections focus on the response to selection within a population based on the initial (‘standing’) genetic variance and can account for selection acting on multiple traits (Lande and Arnold, 1983). Assuming that several genes underlie these traits, quantitative genetic models can accurately predict short-term evolutionary responses to a changing environment given information about the genetic variance for each trait, the covariance among traits, and the strength of selection induced on each trait (see, e.g., Shaw and Etterson, 2012). In practice, this information is unavailable for most species and over large spatial extents. Thus, ranges of plausible values must be inferred – with uncertainty – based on data from other species.

Longer-term projections are made difficult by the need to account for the dynamics of genetic variation. Processes such as mutation and migration that build genetic variance must be modelled (Barton and Turelli, 1989). Selection itself causes allele frequency changes that can increase or decrease genetic variance (de Vladar and Barton, 2014).

While many of these models assume a stable population size, more relevant to our understanding of biodiversity change are models that explicitly account for the feedback between population dynamics and evolutionary change. One theoretical approach focuses on key ecological traits (e.g., resource acquisition traits) that impact population dynamics and whose optimum values shift in a changing environment (Pease et al., 2008; Duputié et al., 2012).

Such models that account for population dynamics are essential for addressing the extinction risk faced by a population. How far and how fast can a population be pushed by environmental change before it collapses? (Bürger and Lynch, 1995; Lande and Shannon, 1996; Gomulkiewicz and Houle, 2009). These models identify the critical speed of environmental change above which evolutionary lags grow over time until populations can no longer persist.

While the above models focus on standing genetic variance, some environmental changes require novel genetic solutions. Recent models have asked when new mutations can ‘rescue’ a population before it goes extinct following an environmental perturbation (e.g., Bell and Collins, 2008; Bell, 2013). These models provide key insights into the factors that promote evolutionary rescue, including the population size, the severity of environmental degradation, and the array of possible rescue mutations (Carlson et al., 2014). Results from these combined evolutionary and population dynamic models can be counterintuitive. For example, while evolutionary adaptation generally works best when the environment changes slowly, evolutionary rescue can be more likely when an environmental shift occurs rapidly, because the release from density-dependent competition helps establish rescue mutations (Uecker et al., 2014).

While the simplest evolutionary models are not spatially explicit, models are increasingly examining how the arrangement of populations and migration rates among them influences evolutionary processes in the face of a changing environment. For example, models have explored the process of evolution to a new or altered environment in the face of migration from the rest of the species range (Gomulkiewicz et al., 1999). Such models can inform policy decisions about the maintenance of gene flow and the importance of migration corridors. Other models explore how the geographical range of a species evolves over time in the face of environmental change. Interestingly, these models are highly sensitive to assumptions made about the dynamics of genetic variance and whether it is held fixed, allowed to evolve deterministically, or subject to random genetic drift (Polechová et al., 2009; Polechová and Barton, 2015). The latter paper clarifies how demographic and evolutionary processes combine to predict whether a species will persist or undergo range contraction when the environment varies over space.

Many evolutionary models focus on genetic changes within a single species. Clearly, it is useful to clarify what might happen in simplified scenarios before adding the complexity of species interactions. To fully account for evolution within models of climate change requires, however, that we account for interactions among species co-occurring within a community. Those models that have considered species interactions suggest that evolutionary responses to environmental change can be fundamentally altered. For example, interspecific competition can hinder evolutionary adaptation and drive extinct a species that would be able to persist if it were on its own (Johansson 2008). Other models demonstrate that accurate predictions require understanding of how selection is shaped by both species interactions and environmental change (Osmond and de Mazancourt, 2013; Mellard et al., 2015).

The results of any model, particularly evolutionary models, are sensitive to the details assumed. What are selection processes and life strategies? How far do individuals migrate? How patchy is the environment? What mutations are neutral or functional? These details matter in predicting whether a species will persist or go extinct.

Evolutionary processes thus raise a great deal of uncertainty in our projections of future biodiversity change in the face of major environmental drivers. Models such as those described above allow us to explore the range of possibilities. Not accounting for evolutionary change is, in most cases, the most conservative assumption for the maintenance of biodiversity (Shaw and Etterson, 2012). On the other hand, allowing evolutionary change under generous assumptions about current and future levels of genetic variance allows us to delimit the most optimistic scenarios for biodiversity in the face of human-caused environmental change.

4.3.1.2 Species- or population-level models

Populations are groups of organisms, all of the same species, which live in a given area and interact. Biodiversity change at the species or population level is often measured using data on population demography and on species distribution (i.e., the distribution of populations within a species). Populations change in size and distribution due to the interaction between internal (e.g., growth rate, reproduction) and external (e.g., resources, predation, diseases) factors. Models building from the simple exponential function, including the logistic population model, life table matrix modelling, the Lotka–Volterra models of community ecology, metapopulation’ theory, and the equilibrium model of island biogeography and many variations thereof are the basis for ecological population modelling to predict changes over time (Gotelli, 2008).

Without the influence of external factors (thus in a density-independent situation), population growth can be modelled as exponential (Vandermeer and Goldberg, 2004). However, as the population size increases, density-dependence factors, such as resource limitation, competition or disease, frequently impact population growth because births and deaths are dependent on population size. Under density-dependence, growth rates slow down and reach a maximum, depicting a sigmoid curve of population size against time, i.e. logistic growth. In the logistic model, the maximum number of individuals in the population is based on the carrying capacity of the system.

The logistic model is frequently used to study the impact of harvesting a population by removing individuals from it (Giordano et al., 2003). Important modifications to the original model include the introduction of critical threshold densities, fluctuations in the carrying capacity and discrete population growth. A popular, but also much debated, example of the logistic growth model is the application to managing fisheries by finding the optimal strategy that maximizes the population growth rate and the long-term yields achieving the maximum sustained yield (Gotelli, 2008). Discussions around this concept are large and include the importance of including species interactions to calculate this reference point in the context of fisheries management (Walters et al., 2005).

Because species do not occur in isolation, the dynamics of any one species affects the dynamics of other sympatric species. In these cases, the logistic equation can be modified to consider the interaction of a population with interspecific competitors, with predators and with prey (Otto and Day, 2007). Lotka and Volterra models for interspecific competition and prey-predator interactions are the classical initial frameworks for competition and predation studies in ecology. These models build from the logistic equations and incorporate the interactions with other populations of competitors, predators and prey, modifying population' growth rates. A classic example of the predator-prey interactions Lotka-Volterra model is the predictions of the regular cycling of population size of Canada lynx (*Lynx canadensis*) and the snowshoe hare (*Lepus americanus*) (Sinclair and Gosline, 1997). An important concept in predator-prey interactions is the functional response of the predator as a function of the prey abundance. This response can be represented as a linear function of prey abundance (called the Type I response). More realistic assumptions incorporate handling time under which the response of the predator increases to a maximum prey consumption rate (Type II response). A variation of the latter incorporates switching with an acceleration of the feeding rate at intermediate prey density and a decrease at high prey density as an asymptote is reached (Type III, Holling 1959). These responses are key elements when modelling the ability of predator species to control prey populations (Gotelli, 2008).

Additionally, populations are often not closed, individuals tend to move between populations, influencing their persistence and survival. Different ways to model sets of populations (or metapopulations) exist. This approach is applied to study linkages of populations at the landscape scale, both in terrestrial and aquatic systems. Methodologies quantify the fraction of all population sites that are occupied, and have been notably applied to study the impacts of protected areas to inform biodiversity conservation (Royle and Dorazio, 2008; Kritzer and Sale, 2010). In addition, the number of species interacting in a specific place depends on the area available for those species to survive and the relationship between species-area holds in most assemblages of organisms worldwide.

This is at the origin of island biogeography that states that the larger an island, the more species it will hold, and the more potential interactions there will be. The original explanation for this pattern was related to habitat types, considering that larger islands include higher diversity of habitats, and thus species restricted to those habitat types will only occur on larger ones (Gotelli, 2008). However, an alternative hypothesis developed with the equilibrium model of island biogeography includes immigration of new species and extinction of resident species as the main force beneath the relationship between area, habitat heterogeneity, and the number of species in a community (Simberloff, 1976; Allouche et al., 2012).

When survival and fecundity rates depend on the age of individuals affecting population growth, age-structured models using the analysis of life table matrices are applied (Otto and Day, 2007; Gotelli, 2008). However, many other parameters can affect vital rates and their variability in space and over time, which is at the core of estimating the risk of extinction or decline of a population.

Population viability analysis, a form of risk assessment analysis, estimates these risks by identifying major threats faced by a population and by evaluating the likelihood of future population persistence (Beissinger and McCullough, 2002; Morris and Doak, 2002).

Population viability analyses are often applied to the conservation and management of threatened or rare species (Akçakaya et al. 2004) with the aim to evaluate options for how to improve chances of survival of populations or species at risk (Akçakaya and Sjögren-Gulve, 2000; Drechsler and Burgman, 2004).

Species occurrence and abundance have often been modelled using correlative methods generally described as species distribution models. Species distribution models have been mainly used to evaluate (1) overall species distributions, (2) historic, present and future probability of occurrence, and (3) to gain understanding of ecological niche limits, which is why this approach is also called ecological niche modelling (Aguirre-Gutiérrez et al., 2013).

Species distribution models are widely used to model the effects of environmental changes on species distribution across all realms (Pearson and Dawson, 2003; Brotons, 2014). The multiple applications of species distribution models is reflected in the diversity of designations used to refer to this type of modelling approach, including, ecological niche models, bioclimatic envelope models, or habitat (suitability) models (Elith and Leathwick, 2009). Modelling approaches that incorporate species abundance data along with species distribution data, for a joint prediction of the effects of environmental drivers on populations' demography and consequently on the overall species distribution, are also being pursued (Ehrlén and Morris, 2015).

Research incorporating expert knowledge into species distribution models is relatively limited. In a study on species distribution modelling, Niamir et al. (2011), however, incorporated existing knowledge into a Bayesian expert system to estimate the probability of a bird species being recorded at a finer resolution than the original atlas data. They noted that knowledge-based species distribution maps of finer scale using a hybrid model/expert system had a higher discriminative capacity than conventional approaches even though such an approach might be limited to well-known species. Further, in a study to evaluate trade offs for using species occurrence data in conservation planning, Rondinini et al. (2006) noted that the geographic range data of species generated by expert knowledge had the advantage of avoiding the potential propagation of errors through data processing steps.

4.3.1.3 Community-level models

Community-level modelling offers an opportunity to move beyond species-level predictions and to predict broader impacts of environmental changes (e.g., Hilbert and Ostendorf, 2001; Pepler-Lisbach and Schröder, 2004; D'Amen et al., 2015), which may be relevant in certain decision-making contexts.

For example, to predict the impact of losing a top predator in the structure of a trophic network or the impacts of land use change in native communities. Community-level approaches are also recommended when time and financial resources are limited, when existing data are spatially sparse or the knowledge on individual species distribution is limited (Ferrier et al., 2002b), or even absent as in the case of non-described species in highly diverse environments, and when species diversity is beyond what can feasibly be modelled at the individual species level. Overall, assessing changes in community composition, including both species presence and abundance, and how those changes affect ecosystem processes provides a more detailed understanding of the impacts of drivers (Newbold et al., 2015). Moreover, species richness, a community-level metric, is a commonly used biodiversity indicator (Mace et al., 2012).

Community-level distribution models, as for species distribution models, use environmental data to predict the distribution of species assemblages or communities. Data input needs are similar to species distribution model inputs but model outputs are more diverse and can be classified into five main types (Ferrier and Guisan, 2006): community types (groups of locations with similar species composition), species groups (groups of species with similar distributions), axes or gradients of compositional variation (reduced space dimensions of compositional patterns), levels of compositional dissimilarity between pairs of locations, and various macro-ecological properties (e.g., species richness) and even phylogenetic diversity.

Ferrier and Guisan (2006) and D'Amen et al. (2015) identify three approaches to community-level modelling (Figure 4.4): (1) 'Assemble first, predict later', whereby species data are first combined with classification or ordination methods and the resulting assemblages are then modelled using machine learning or regression-based approaches, (2) 'Predict first, assemble later', whereby individual species distributions are modelled first and the resulting potential species distributions are then combined (i.e. the result is in fact the summation of individualistic models), and (3) 'Assemble and predict together', whereby distributions of multiple species are modelled simultaneously using both environmental predictors and information on species co-occurrence pattern.

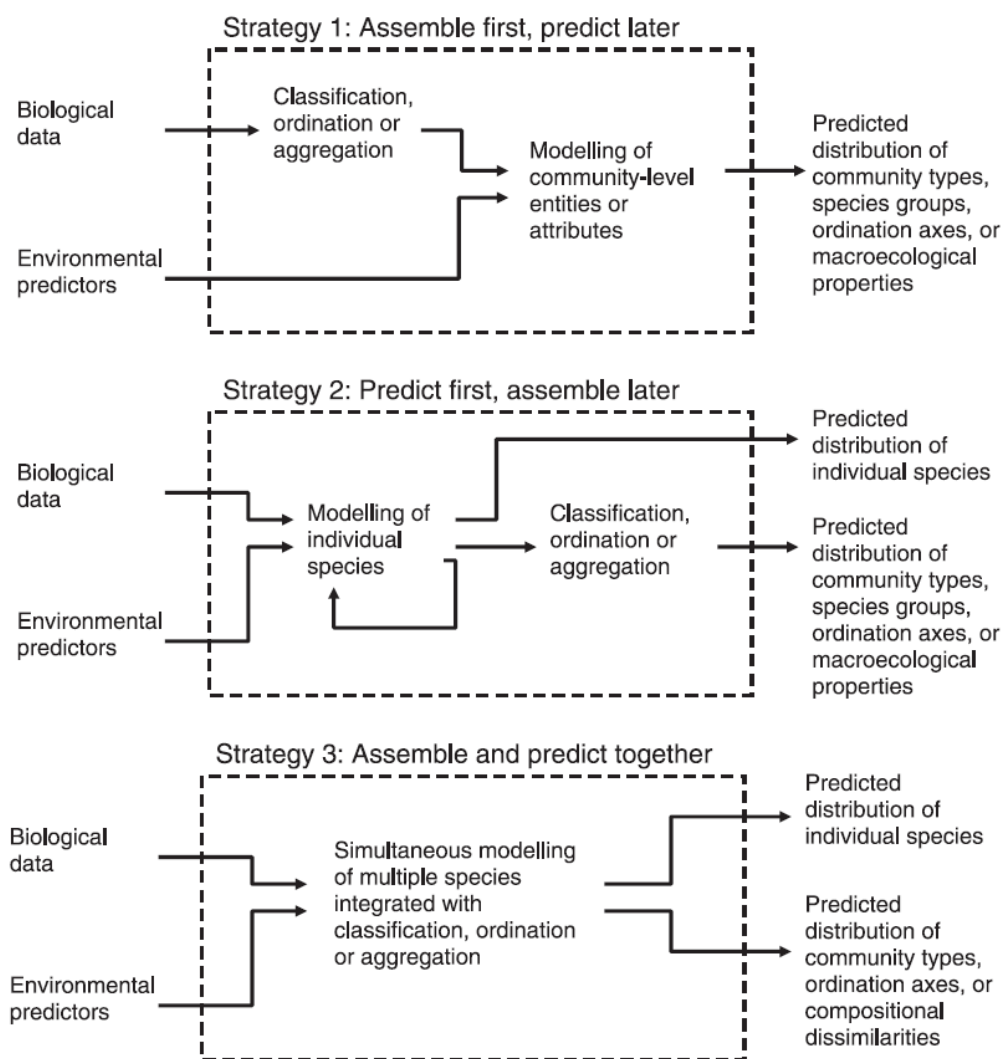

Figure 4.4: Main approaches to community-level distribution models (Source: Ferrier and Guisan, 2006).

These approaches have different strengths (D'Amen et al., 2015). The first and third approach are more able to capture overall patterns of response and are better options if rare species, for which distribution data may be scarce, represent a significant fraction of the species assemblage. But, the second approach allows more flexibility, in how different species respond to different environmental factors, though it may fail to produce reliable projections of rare species' distributions (Ferrier and Guisan, 2006). Similar reasoning can be used when deciding to use species distribution models or community-level models to assess community responses. Species distribution models can provide more reliable predictions of well-sampled species, but may fail with rare species, and are resource-demanding when applied at the community level.

The strengths and weaknesses of community-level modelling approaches, and the applicability of community models are discussed by Ferrier et al. (2002a), and by Ferrier and Guisan (2006). More recently, D'Amen et al. (2015) have highlighted potential research avenues and proposed novel integrative frameworks to push the state of the art in spatial predictions at the community level. As in species distribution models, correlative community-level distribution models can also integrate ecological processes to enhance their predictive ability (D'Amen et al., 2015), such as meta-community dynamics and species interactions (Mokany and Ferrier, 2011).

4.3.1.4 Ecological Interaction Networks

Ecological interaction networks include, among other examples, trophic webs and plant-pollinator webs (Ings et al., 2009). Species interactions within communities can be explicitly modelled using process-based approaches that describe the links between species and the dynamics that determine species coexistence in the network, such as predator-prey oscillations (Verhoef and Olff, 2010).

Network topology is also an important consideration when building interaction models, since the links between elements may follow a non-random pattern. In food webs, interactions patterns are shaped by body size, which justifies the use of size-structured models (Woodward et al., 2005; Loreau, 2010).

Correlative approaches are also frequent in studies of interaction networks, due to their lower information requirements, but Ings et al. (2009) advocate against the use of inferential approaches, and recommend pursuing more mechanistic approaches that build on first principles and on ecological theory. Similarly, applications in modelling marine ecosystems will require coupling of different trophic levels that may have different characterisations. One way to represent biodiversity in complex marine systems would be to concentrate the detail of representation at the target species and their main interactions at the community level (FAO, 2008). Community interaction network approaches have been used to assess the impacts of, e.g., invasive species (Woodward and Hildrew, 2001), overfishing of top predators (e.g., Bascompte et al., 2005), biodiversity and ecosystem function relationships (Fung et al., 2015), freshwater pollution (e.g., Scheffer et al., 1993) and climate warming (Petchey et al., 1999).

Outputs from community-level distribution models can be used to inform species traits approaches, assessing the composition of impacted communities. Species traits approaches can also be linked to interaction network models to predict how changes in community traits will affect ecosystem functioning (Harfoot et al., 2014b). Species traits approaches move the focus from species composition in a community to the distribution of traits or average trait values in the community. Species traits underlie species responses to drivers, that is, their ability to cope with environmental change, but also their role in environmental processes. Therefore, the distribution of trait values in a community (e.g., root depth, body size, forage range) may not only inform on the vulnerability of the community to changes in drivers, but also on the effects of community compositional change to ecosystem functioning, and consequently to ecosystem services (Lavorel and Garnier, 2002; Suding et al., 2008; Oliver et al., 2015). Trait-based ecological risk assessments is an example of a trait-based approach to assess ecological responses to natural and anthropogenic stressors based on species characteristics related to their functional roles in ecosystems (Baird et al., 2008).

Another approach commonly used to assess community change over time is through species-area relationship models. These are used to predict species richness as a function of habitat area. Species-area relationship models have been tested and applied to a wide range of taxa and across all scales, from local to global (e.g., Brooks et al., 2002; Brooks et al., 1997). Species-area relationship models are often used to predict the impacts of changes in habitat availability, driven by land use change (e.g., van Vuuren et al., 2006; Desrochers and Kerr, 2011) or climate change (e.g., Malcolm et al., 2006; van Vuuren et al., 2006), on community richness, but also to assess the impacts of direct exploitation on community parameters, such as species-turnover rates (e.g., Tittensor et al., 2007). Reviews on the use of species-area relationships can be found in Rosenzweig (2010), Drakare et al. (2006), and Triantis et al. (2012).

The most common species-area relationship model is the power function (Arrhenius, 1921), $S=c A^z$, where S is species richness, A is habitat area, and c and z are model parameters (Rosenzweig, 2010). Notwithstanding the general use of the power function, species-area relationship models may be best described by other functions or by averaging the predictions of alternative models (i.e., multi-model species-area relationship approaches) when there isn't a single best model (Guilhaumon et al., 2008). Another important caveat, relates to the risk of species-area relationship overestimating predicted species loss due to habitat loss (Pereira and Daily, 2006). This limitation can be addressed through the use of modified species-area relationship approaches that better represent community dynamics, such as the species-fragmented area relationship (Hanski et al., 2013), which considers the effects of habitat fragmentation on species diversity patterns, and the countryside species-area relationship (Proença and Pereira, 2013), which accounts for the differential use of habitats in a landscape by different species groups.

4.3.1.5 Ecosystem-level models and integrated models

Ecosystem level models may focus on the biophysical dimension of ecosystems (e.g., Dynamic Global Vegetation Models), or they can be developed to also include economic and social aspects (e.g., EwE models, see Chapter 5).

Dynamic Global Vegetation Models are process-based models that simulate various biogeochemical, biogeophysical and hydrological processes such as photosynthesis, heterotrophic respiration, autotrophic respiration, evaporation, transpiration and decomposition.

Dynamic Global Vegetation Models are the most advanced tool to estimate the impact of climate change on vegetation dynamics at global scale (Smith et al., 2001). They simulate shifts in potential vegetation and the associated biogeochemical and hydrological cycles as a response to shifts in climate. Dynamic Global Vegetation Models use time series of climate data and, given the constraints of latitude, topography, and soil characteristics, simulate monthly or daily dynamics of ecosystem processes. Dynamic Global Vegetation Models are most often used to simulate the effects of future climate change on natural vegetation and its carbon and water cycles. Increasingly Dynamic Global Vegetation Models are being coupled with Atmosphere-Ocean General Circulation Models to form Earth System Models.

The basic structure of a Dynamic Global Vegetation Model is given in Figure 4.5.

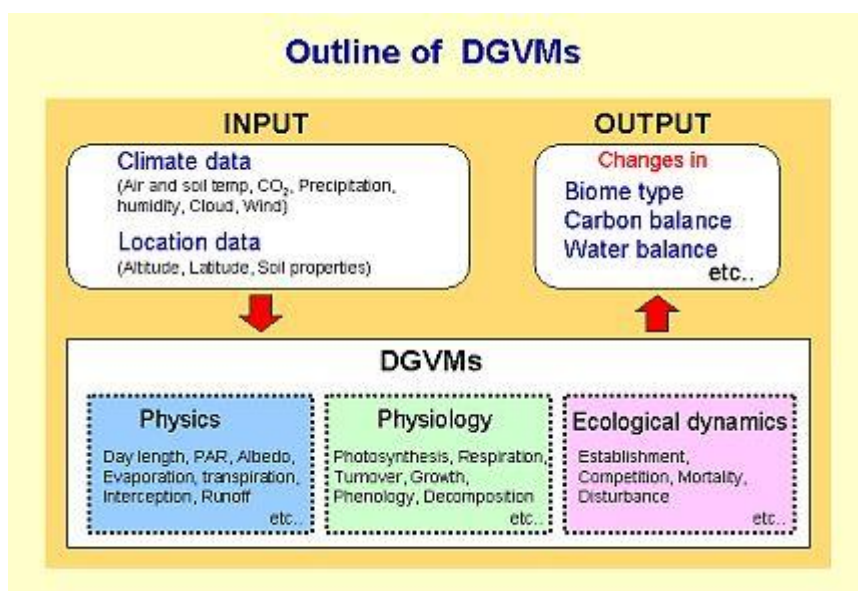

Figure 4.5: Structure of Dynamic Global Vegetation Models (Source: <http://seib-dgvm.com/oview.html>).

Dynamic models capture the transient response of vegetation to a changing environment using explicit representation of key ecological processes such as establishment, tree growth, competition, death, nutrient cycling (Shugart, 1984; Botkin, 1993). Plant functional types are central to Dynamic Global Vegetation Models as, on the one hand, they are assigned different parameterizations with respect to ecosystem processes (e.g., phenology, leaf thickness, minimum stomatal conductance, photosynthetic pathway, allocation, rooting depth), while on the other, the proportion of different plant functional types at any point in time and space defines the structural characteristics of the vegetation (Woodward and Cramer, 1996).

The key advantages of using Dynamic Global Vegetation Models include the capacity to simultaneously model the transient responses related to dynamics of plant growth, competition and, in a few cases, migration. As such it allows the identification of future trends in ecosystem functioning and structure and these models can be used to explore feedbacks between biosphere and atmospheric processes (Bellard et al., 2012). The Dynamic Global Vegetation Models, however, are focused on a limited number of plant functional types, which induces a high level of abstractedness (Thuiller et al., 2013).

Adding a further level of complexity beyond ecosystem modelling is achieved through Integrated Assessment Models (IAMs, see Figure 4.6), which were defined in the IPCC Third Assessment Report (IPCC, 2001) as ‘an interdisciplinary process that combines, interprets, and communicates knowledge from diverse scientific disciplines from the natural and social sciences to investigate and understand causal relationships within and between complicated systems’.

It is generally agreed that there are two main principles to integrated assessment, i.e. integration over a range of relevant disciplines; and the provision of information suitable for decision-making (Harremoes and Turner, 2001). IAMs thus aim to describe the complex relationships between environmental, social, and economic drivers that determine current and future states of the system and the effects of climate change, in order to derive policy-relevant insights (van Vuuren et al., 2009). One of the essential characteristics of integrated assessment is the simultaneous consideration of the multiple dimensions of environmental problems. At the global level, IAMs could potentially be a valuable tool for modelling biodiversity dynamics under different drivers; however, current IAMs are not developed for this application (Harfoot et al., 2014a). Existing IAMs are largely used for modelling climate change and investigating options for climate mitigation. Key outputs from IAMs include anthropogenic greenhouse gas emissions. However, these also provide projections for other variables, including: land cover and land use (including deforestation rates).

One of the most noticeable limitations of IAMs is that they are focused largely on terrestrial systems, not aquatic ecosystems, either marine or freshwater (as shown in Figure 4.6, which provides a schematic representation of a typical IAM). Other notable limitation includes the lack of feedback from changes in biodiversity, ecosystem functions, and terrestrial ecology on other drivers such as climate change and land use change. For example, actions that reduce the number or composition of species in natural systems may compromise ecosystem functioning, as the ability of ecosystems to provide services may depend on both these aspects (Tilman et al., 2001; Loreau et al., 2001; Hooper et al., 2005; Isbell et al., 2011). CLIMSAVE at the European level not only integrates sectorial models but also has feedbacks and can be used to explore the impacts of selected adaptation options (Harrison et al., 2015).

IAMs typically describe the cause-effect chain from economic activities and emissions to changes in climate and related impacts on e.g. ecosystems, human health and agriculture, including some of the feedbacks between these

elements. In order to make their construction and use tractable, many IAMs use relatively simple equations to capture relevant phenomena, e.g., for the climate system and carbon cycle (Goodess et al., 2003). However, the behaviour of these components can have a significant impact on IAM results and the quality of policy advice, with the possibility of simplifications in the earth system projections leading to imprecision (or even error) in projecting impacts and costs of mitigation.

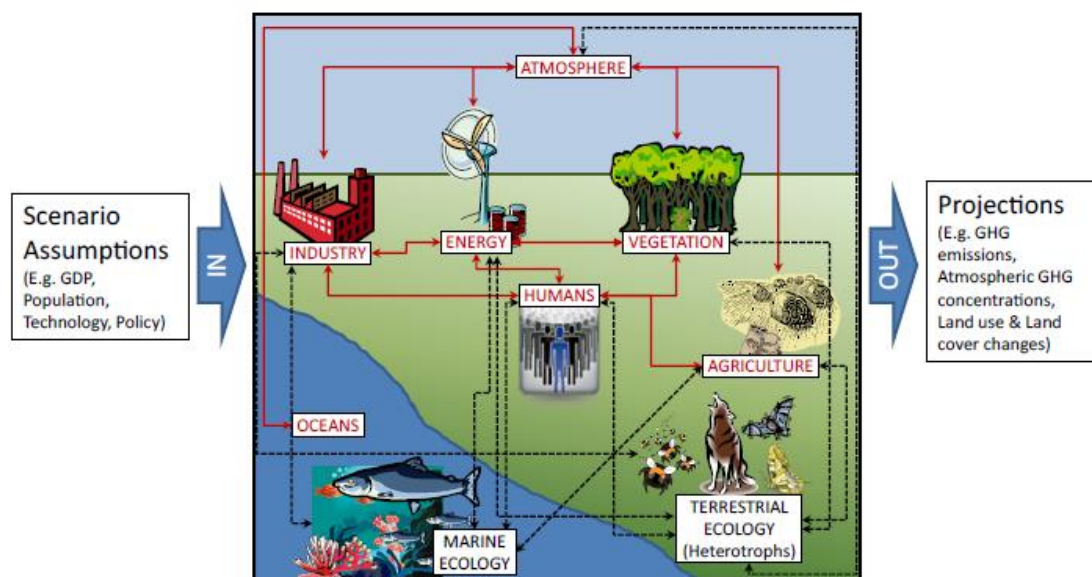

Figure 4.6: Schematic representation of a typical full-scale integrated assessment model. Red labels and arrows represent existing model components and interactions, while black labels and black dashed arrows indicate important components and interactions not currently included. (Source: Harfoot et al., 2014a).

Over the last decade, IAMs have expanded their coverage in terms of land use and terrestrial carbon cycle representation, non- CO_2 gases, and air pollutants, and by considering specific impacts of climate change. Some IAMs have a stronger focus on economics, such as multi-sectoral computable general equilibrium models that are combined with climate modules and models focused on cost–benefit analysis, others focus on physical processes in both the natural system and the economy (integrated structural models/biophysical impact models). Examples of IAMs are (IMAGE) Integrated Model to Assess the Global Environment, DICE (Dynamic Integrated model of Climate and the Economy), FUND (Climate Framework for Uncertainty, Negotiation and Distribution) and MERGE and they include key drivers of change such as population and macro-economy, which can be derived from various external and internal sources.

However, as IAMs aim to integrate different aspects of the environment, they run the risk of becoming extremely complex. Thus, the developers of such models have to make decisions about the focus of their study and how to express the impacts they estimate, whether it is through the reporting of physical changes in emissions, shifts in land-use activity or mortality rates, or through cost-benefit analysis of damages resulting from climate change (Goodess et al., 2003). The data requirements for these IAMs are also large and not always feasible.

4.3.2 Modelling options, strength and limitations

4.3.2.1 Meeting policy information needs

Models allowing the assessment of impacts of changes in drivers on biodiversity or ecosystem processes are important tools to support decision-making. To be effective, models should be able to address the policy or decision-making needs that motivate their use. A formal and accurate definition of the decision-making context is therefore essential in this process (Guisan et al., 2013). A precise definition of the policy or decision context should inform the selection of a modelling framework including model complexity, spatial and temporal scales or response variables and data requirements (Chapter 2). State variables should be sensitive to the pressures underlying alternative management scenarios or addressed by policies, and, if possible, be responsive at temporal and spatial scales that are relevant for policy strategies. For example, small farmland birds are responsive to agro-environmental schemes implemented at the field scale, while large farmland birds are more affected by larger spatial scales (Concepción and Díaz, 2011). Moreover, state variables should also be representative of the biodiversity attributes underpinning the benefits of nature that are valued in a given decision-making context.

Regarding model scope, models should be adjusted to the specific requirements of the decision-making context. Models could rely on observed data to describe the relationship between pressures and response variables, explicitly describe the processes linking those variables, or follow an intermediate approach. The explicit inclusion of

mechanisms in modelling approaches will be relevant whenever the understanding of the underlying dynamics is necessary to guide management and where changing environmental conditions call for a mechanistic approach (Gustafson, 2013; Collie et al., 2014). The use of correlative approaches, on the other hand, is suitable where there is limited knowledge about the underlying mechanisms or when model outputs are able to capture the dominant response patterns that are needed to inform policy, such as the evaluation of large scale conservation initiatives (Araújo et al., 2011; Dormann et al., 2012).

As for model complexity, input data requirements should be balanced against data availability and quality, namely the spatial and temporal resolution of available data, as the lack of adequate input data may compromise model feasibility and the quality of results (Collie et al., 2014). The ongoing development of new technologies and of remote sensing to monitor species and ecosystems, but also of the platforms for data sharing, is encouraging as it is resulting in increased data availability and accessibility (Pimm et al., 2014). The integration of local observations and remote sensing products can provide a more complete view of the responses of biodiversity to environmental change and can improve the modelling of ecosystem processes across scales (Pereira et al., 2013; Pimm et al., 2014).

Table 4.3

Summary of major biodiversity models and modelling approaches

Model	Level of organization	Model type	Level of integration	Required level of expertise	Examples	References
Evolutionary models	Organisms	Mixed (hybrid)	Integrated models	High	How demographic and evolutionary processes combine to predict whether a species will persist or not	Polechová and Barton, 2015; Barton, 2001
Dynamic Energy Budget models	Organisms	Mechanistic	Integrated models	High	To understand evolution of metabolic organisation	Kooijman, 2009
Aquatic habitat suitability	Community	Expert-based models	Single model	Basic	To link environmental conditions to the quantitative habitat suitability of aquatic species	Mouton et al., 2009
Species distribution models	Species/Populations	Mainly correlative	Single or integrated models	Basic – Moderate	Used to model the effects of environmental change on species distribution	Pearson and Dawson, 2003; Elith and Leathwick, 2009; Stockwell and Peters, 1999; Phillips et al., 2006
Dynamic Bioclimate Envelope Model	Species/Populations	Mixed (hybrid)	Integrated models	Moderate	Changes in the relative abundance of marine species induced by change in climatic variables	Cheung et al., 2008a, 2008b, 2011; Gallego-Sala, 2010; Notaro et al., 2012; Fernandes et al., 2013
Age/stage-structured models	Species/Populations	Correlative	Single model	Basic	Widely used for fisheries management	Hilborn and Walters, 1992; Getz, 1988; Barfield et al., 2011
Food web models	Ecosystems	Process-based	Integrated models	Moderate	Widely used for ecosystem-based management	Christensen and Walters, 2011
Size-based models	Community	Correlative	Single model	Basic	Impact of size in marine and freshwater ecosystems management	Duplisea et al., 2002; Rochet et al., 2011

Species-area relationship models	Community	Correlative	Single model	Moderate	Used to predict the impacts of changes in habitat availability, driven by land use change or climate change	van Vuuren et al., 2006; Desrochers and Kerr, 2011; Pereira et al., 2013; Huth and Possingham, 2011
Biodiversity metric models	Community	Correlative	Integrated models	Moderate	A quantitative and integrated approach to assess the biodiversity with multiple indicators	Janse et al., 2015
Lotka-Volterra	Community	Process-based	Integrated models	High	For interspecific competition and prey-predator interactions	Sinclair and Gosline, 1997
Dynamic Global Vegetation Models	Ecosystem	Process-based	Integrated models	High	To estimate the impact of climate change on vegetation dynamics at global scale and its carbon and water cycles	Botkin, 1993; Bellard et al., 2012; Cramer et al., 2001
General ecosystem model	Global	Process-based	Integrated models	High	Uses a unified set of fundamental ecological concepts and processes for any ecosystem to which it is applied, either terrestrial or marine, at any spatial resolution	Harfoot et al., 2014b
IAM	Global and regional	Integrated	Multiple models	High	Interdisciplinary assessment	Harremoes and Turner, 2001; Tilman et al., 2001

4.3.2.2 Predictability

No model can capture the full complexity of ecosystems and perfectly predict biodiversity patterns and ecosystem function as impacted by a suite of drivers, such as through climate change or habitat modification (Bellard et al., 2015). Yet, models are useful to synthesize data, evaluate alternative hypotheses, and to provide projections about potential future states.

This is illustrated by the study of Bellard et al. (2012), who reviewed the approaches that are most commonly used for estimating future biodiversity at global and regional scales. They found that projections from the different approaches vary considerably, depending on method, taxonomic group, biodiversity loss metrics, spatial scales and time periods. Still the overall projections from the majority of the models indicated that the future trends for biodiversity were alarming. This reiterates a general finding from the IPCC that projections from individual models should not be taken at face value. Instead an ensemble approach accommodating uncertainty in multi-model prediction is required for interpreting trends and for comparisons between models. Comparisons that involve applying numerous models to evaluate a given policy question (e.g., related to efficiency of alternative measures for minimizing impact of climate change) provide a means not just for evaluating uncertainty, but as importantly for studying why the models give different answers. This may indeed lead to feedback that impact not just the individual models, but also the underlying theory that is used for the model developments (see Figure 4.7).

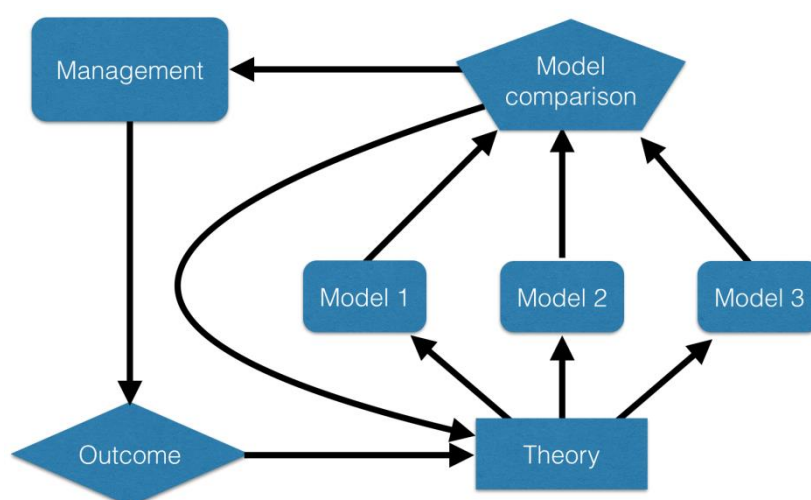

Figure 4.7: An overview over relationships between ecological theory, models, comparison and management. There may be numerous models to represent a given theory, and both the model comparisons and the management outcome may provide feedback to theory (Modified from Cuddington et al., 2013).

In many research fields it is becoming standard practice for model fitting and statistical procedures to test model predictions on a known, typically simulated, data set in order to assess model behaviour and characteristics (e.g., in fisheries assessment, Hilborn and Walters, 1992). For models of complex natural systems it is often not possible to test model predictions against simulated data, but a minimum requirement for such is that the models are ‘validated’ by demonstration of each model’s capability to at least exhibit the same behaviour as what has been observed historically (Rykiel, 1996). Validation here means consistency with observation (for instance as tested through time series fitting with formal information criteria evaluation).

As an example of a comprehensive model validation exercise, Elith and Graham (2009) constructed the distribution of an artificial plant species based on its affinity along three axes, related to preference for wetness, aspect (‘southness’) and geology, to obtain a ‘true’ spatial distribution for the plant. They constructed a spatial subsample of parameters (along the three axes), and used this to parameterize five different, commonly applied Species Distribution Models. By next predicting the full distribution for each method, they could validate model performance using true-false positive and negative patterns as well as evaluation of predictions versus true values. The study, in addition to the direct evaluation of model performance, also demonstrated that model comparisons can be used to evaluate why different models give different predictions – which can be used for further developments of models as well as refinement of ecological theory (see Figure 4.7).

While model comparisons are both needed and feasible, as demonstrated by the study of Elith and Graham (2009), they are difficult to conduct by any one research group as soon as the models involved are complex and in practice require both specific capacity and experience to be run optimally. For this reason, it is extremely important to build capabilities for inter-model comparisons, following in the footsteps of the Coupled Model Inter-comparison Projects (CMIP) of the IPCC. Similar activities are now underway for biodiversity research as part of the Inter-Sectoral Impact

Model Inter-comparison Project (ISI-MIP), which is a community-driven modelling effort that brings together impact models across sectors and scales to create consistent and comprehensive projections of climate change impacts.

4.4 Modelling feedbacks and interactions

Both human and non-living environmental drivers influence biodiversity and ecosystem functions through a number of processes. In turn, biodiversity exerts feedbacks on both systems (Figure 4.8). Consideration of the feedbacks is important as they may cause non-linearity in interaction dynamics, which potentially can move a system beyond thresholds and tipping points, (e.g., regime shift: Lenton, 2011).

Changes in biodiversity interact with different drivers of biodiversity change (e.g., climate change, disturbance regimes such as forest fires, invasive and pests, and ecosystem processes) over different temporal and spatial scales. Changes in biodiversity and shifts in the distribution of plant traits can influence climate at global and regional scales. For instance, General Circulation Models based on simulations indicate that widespread replacement of deep-rooted tropical trees by shallow-rooted pasture grasses would reduce evapotranspiration and lead to a warmer, drier climate (Shukla et al., 1990). Similarly the replacement of snow-covered tundra by a dark conifer canopy at high latitudes may increase energy absorption sufficiently to act as a powerful positive feedback to regional warming (Foley et al., 2000).

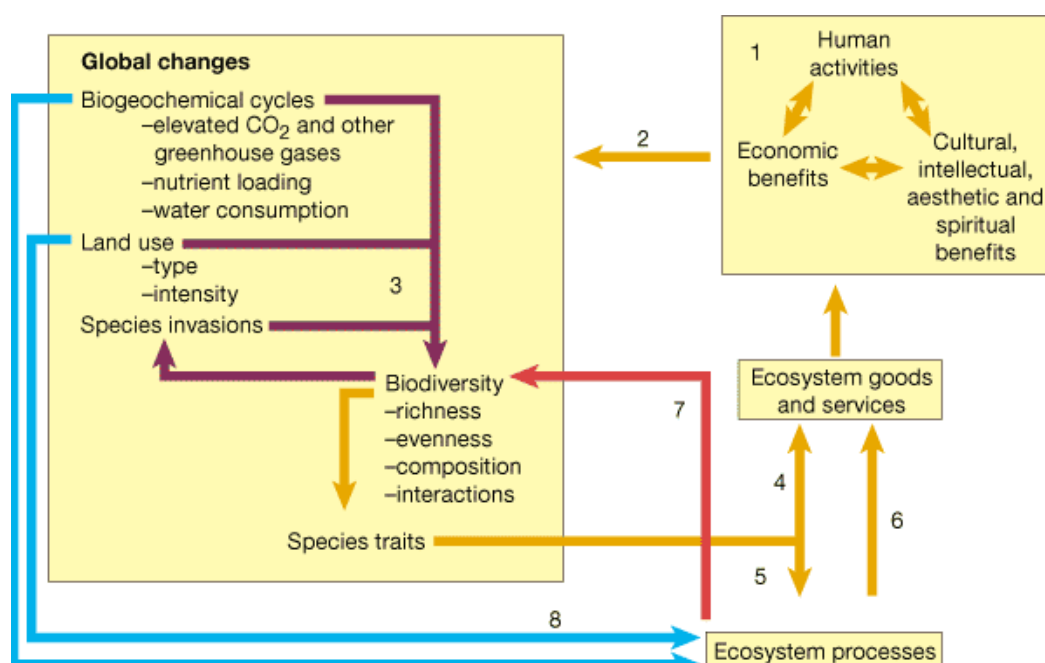

Figure 4.8: Schematic diagram of interactions between biodiversity, the human system and the non-living environment used for evaluating feedbacks related to species invasions. The figure represents feedbacks between biodiversity, drivers of biodiversity change and the interactions between these drivers. (Source: Chapin et al., 2000).

Feedbacks between drivers and biodiversity or ecosystem levels usually involve high level of complexity in the models because changes in state variables at different levels (either biological or others) should be able to interact and cause emergent dynamics. Changes in biodiversity for instance can impact disturbance regimes such as fire, which in turn is strongly determined by climate (Pausas and Keeley, 2009) and fire-suppression efforts (Brotons et al., 2013).

Biodiversity and ecosystem models as discussed in Section 4.3, describe the impact of abiotic drivers such as climate, nutrient cycling, atmospheric concentration of greenhouse gasses (GHGs) including CO₂, water resources, fires, and land-use on the biotic systems including its biodiversity and the ecosystem services. Many of the modelling approaches are capable of simulating the feedback of the biotic system on abiotic and human drivers as well. For example, many of the process-based models including the Species Distribution Models simulate the carbon sequestration in the vegetation and soils and thus impact the atmospheric greenhouse gases. Process-based models can also simulate feedbacks from vegetation change to forest fires (LANDIS). Further many of the Dynamic Global Vegetation Models (ex-IBIS Foley et al., 1996; Kucharik et al., 2000; Sitch et al., 2003) are able to simulate the feedback of the biotic system to water resources. However only a few Dynamic Global Vegetation Models include detailed feedback to nutrient cycling. Dynamic Global Vegetation Models have been also used to study feedback between vegetation and past climate. General Circulation Models/ Atmosphere-Ocean General Circulation Models too include vegetation feedbacks to climate. Neither the process based models including Dynamic Global Vegetation Models nor the General Circulation Models/ Atmosphere-Ocean General Circulation Models include the feedback of biodiversity and ecosystems to human societies. However, IAMs are capable of simulating impacts of changes in biodiversity and ecosystems on human systems including its economic activities.

4.5 Model complexity

Matching model complexity to policy and decision-making needs while keeping the model as simple as possible is a major challenge in future development of biodiversity and ecosystem models (Merow et al., 2014). We here describe three general strategies that should help limit model complexity: model what matters, adopt hierarchical modular modelling approaches, and standardize protocols for model communication.

The first general strategy is the formulation of critical biological processes directly relevant to the question addressed or the problem to be dealt with. Avoiding unnecessary increases in model complexity requires a careful assessment of the biological processes that most directly affect species distributions at the spatial and temporal scales of interest for each particular study (Guisan and Thuiller, 2005). Although there is no general recipe to select the relevant biological processes, those related to species auto-ecology will always have a central role. Habitat selection and population dynamics in species-level models may be formulated with more or less detail, but are fundamentally important to predict species distribution dynamics (Willis et al., 2009; Kunstler et al., 2011).

Biological processes should be modelled explicitly and internally (i.e. using process-based models) only when they are critical for the questions at hand. The remaining processes can be modelled externally and formulated into the model by means of input spatial layers or parameters modified by additional modelling frameworks (Smith et al., 2001). Such an approach may facilitate the flexible structuring of models by allowing sub-models to be plugged into one another (e.g., McRae et al., 2008). In this modular structure, the upper levels provide external contextual information (and hence external dynamics) to the lower ones. Hierarchical modular structures have the advantage of: (1) more easily integrate across different spatial and temporal scales (e.g., to downscale the results of processes formulated at higher levels; del Barrio et al., 2006); and (2) assess the levels of uncertainty added at each stage (Larson et al., 2004; Chisholm and Wintle, 2007). However, modularity may be limited for those target species that modify their environment or interact with other biotic entities (Midgley et al., 2010). Research is needed to compare the outputs of models with different degrees of complexity in light of validation data appropriate for the process or driver under study (Roura Pascual et al., 2010). Only in this case will it be possible to build a body of reference regarding the minimum acceptable levels of complexity to analyse a given problem.

4.6 Accounting for uncertainty

Policy making related to biodiversity and ecosystem functioning must take place based on the currently available knowledge. This must be done recognizing that uncertainty is associated with all science, including modelling, due to limitations of data, representation of processes, and resolution of the ecosystem scale. Environmental complexity is an emergent property of the environment – it's not just that our models have limitations.

The fact remains that the environment is incredibly complex and interconnected. However, policy makers have to make decisions even in the face of uncertainty, to act on drivers in order to conserve ecosystems and biodiversity. To support decision-making, models aim at synthesizing this complexity into a reasonable number of dimensions.

In biodiversity and ecosystems modelling the uncertainty arises from two primary sources i.e., model uncertainty and the uncertainty in the input parameters (or scenario uncertainty). Different models represent different physical processes differently and to varying extent and details. This leads to model uncertainty. Input parameters for example, climate projections add to the modelling uncertainty. An example of model uncertainty is that models generally do not take into account tipping points and non-linearity (Whiteman et al., 2013). Additionally, many of the models generally leave out the natural processes and feedbacks that are difficult to model with the current state of knowledge, even though these processes may cause large impacts. An example of the uncertainty from input parameters is the uncertainty inherent in climate or land-use change projections. Besides, existing impact assessment studies including the biophysical and integrated assessment models (IAM) generally tend to work with the mean of the probability distribution of projected impacts, neglecting the low-probability, high impact tails of the distribution (Weitzman, 2009; Ackerman et al., 2010; Marten et al., 2012). Impact studies generally focus on single-sector or single region-based assessments. The potential interactions, among sectors and regions, which can adversely impact biodiversity and ecosystems, are not adequately included in the quantitative estimates (Warren, 2011).

Similarly the ambient policy and management practices and socio-economic stresses leading to degradation of natural resources are also not included in most of the sectoral impact assessment models. Key human related issues such as armed conflicts, migrations and loss of cultural heritage have a lot of potential to impact natural ecosystems, however impact assessment models do not include these stresses related to the human systems (Hope, 2013). IAM based economic analyses of impacts are generally conservative as these studies make optimistic assumptions about the scale and effectiveness of adaptation (Marten et al., 2012; Hope, 2013). In this section we present the sources of uncertainty in models of biodiversity and ecosystems, some options to address uncertainty and approaches to communicating uncertainty.

4.6.1 Sources of uncertainty

Link et al. (2012) and Leung et al. (2012) highlighted six major sources of uncertainty confronting ecosystem modellers (Figure 4.9).

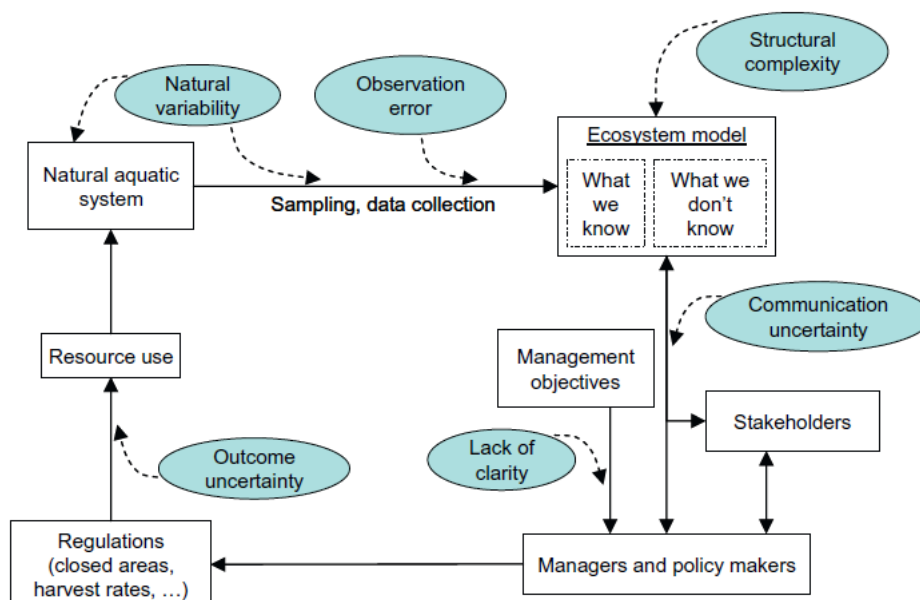

Figure 4.9: A conceptual diagram of the flow of information and actions in a typical LMR management system. Rectangles represent components of the system, solid arrows indicate flows of information and actions between components, and ellipses represent major sources of uncertainty. (Source: Link et al., 2012).

4.6.1.1 Natural variability

Natural variability or stochasticity includes biological differences among individuals, either within the same environment (genetic differences) or between environments (plasticity), differences among populations within a community, changes in spatial distributions through time, density-dependent or independent variation in a vital rate, seasonal or inter-annual variability in realized environmental conditions, or shifts in productivity regimes. Natural variability increases ecosystem model uncertainty by reducing the precision of parameter estimates.

4.6.1.2 Observation error

Observation error is inevitable when studying organisms in either a single species or an ecosystem context (e.g., Morris and Doak, 2002; Ives et al., 2003, as cited in: Link et al. (2012)). The environmental characteristics of a particular area (even those that we can measure fairly accurately) are difficult to relate directly to the full experience of mobile organisms that move into and out of that area. Thus, natural variability can actually exacerbate observation error. Observation error adds uncertainty to ecosystem models through reduced precision, mis-specified parameter distributions, and biased parameter estimates.

4.6.1.3 Structural complexity

The structural complexity of a model arises from many factors, such as the number of parameters it includes; the number of ecosystem components and processes it simulates; the temporal scale; the nonlinearities, log effects, thresholds, and cumulative effects incorporated in those processes; and whether or not it includes features such as spatial dynamics or stochasticity (Fulton et al., 2003). Structurally complex ecosystem models are gaining in use, in part due to improved computing capabilities and also to the intricate, multi-sector, cross-disciplinary questions commonly being addressed in ecosystem-based management.

Ecosystem models are diverse in terms of scope and approach, but share the general feature of a large number of parameters with complex interactions. These models are necessarily built with imperfect information. Given these inevitable uncertainties, large and complex ecosystem models must be evaluated through sensitivity analyses, with independent data before their output can be effectively applied to conservation problems (McElhany et al., 2010). Uncertainty in climate change scenarios arises from different greenhouse gas emission storylines and from differences between climate models even if driven with the same storylines (McElhany et al., 2010). This can be partly addressed by using climate change scenario data from several emission storylines but also by using results from multi-model studies (i.e. an ensemble of climate models). Process-based models are widely used to assess the impacts of climate change on forest ecosystems (McElhany et al., 2010). Climate change impact studies that do not integrate parameter uncertainty may over- or underestimate climate change impacts on forest ecosystems.

4.6.2 Options for reducing uncertainty

All model types carry multiple uncertainties, but there are potential options for reducing uncertainty as discussed by Beale and Lennon (2011). It is important to establish the full range of model behaviours by carrying out a sensitivity analysis by considering different combinations of models and parameters. Sensitivity analysis is useful to determine

the importance of each source of uncertainty. Apart from the sensitivity analysis of the model parameters, it is also important to consider the interaction between models and the data. Further, running each model multiple times can assess the full range of model behaviour, parameter uncertainty and natural variability. One of the ways to assess uncertainty is to apply a mixed approach to uncertainty assessment comprising both the model and scenario uncertainty (Dunford et al., 2014). Further, there is a need to identify bifurcation points and decision nodes in models and scenarios, and it should be supplemented by monitoring the system as it approaches these nodes to verify system behaviour. Monitoring can lead to reduction in the model and scenario uncertainty by making adjustment to the model/(s), in the light of the observations through the process of ‘data assimilation’.

One of the ways to reduce uncertainty is to use multi-model ensembles (averages/weighted average), where it is suggested to avoid averaging model results unless the distribution of results suggested by all models is unimodal. Multi-model ensemble is not the only way multiple model types can be combined. Different model types can be joined statistically as well. For example, niche-based models and demographic- or process-based models could be integrated across spatial scales in a hierarchical framework, or more simply, Dynamic Global Vegetation Model output could feed into species distribution models to better predict species reliant on particular biomes.

4.6.3 Communicating uncertainty

An important consideration is the effective communication of these uncertainties in the presentation of assessment and modelling results. The purpose of the study strongly determines what uncertainty information is relevant and when to communicate uncertainty to policy and decision makers, and it is important to convey at least the robust main messages from a modelling assessment (Kloprogge et al., 2007).

The main challenge in developing a generic guideline for communicating uncertainty is that each assessment or decision-support context is unique. For example, for species distribution modelling Gould et al. (2014) report that the spatial distribution of uncertainty is not homogeneous and can vary substantially across a species’ predicted habitat, and the way uncertainty is spatially distributed depends on how the uncertainty impacts the model specification. Further, modellers often encounter situations where a number of potential sources of uncertainties cannot be quantified. In these situations Gould et al. (2014) recommend that all potential sources of uncertainty should at least be systematically reported along with model outputs.

Communicating uncertainty not only involves reporting on the uncertain aspects of the models themselves, but also provides insight into these aspects by elaborating on questions such as: Where do the uncertainties originate? What significance or implications do they have in a given policy or decision context? For instance, how might a reduction in uncertainty affect the decisions to be made? Can uncertainty be reduced? And how is uncertainty dealt with in the assessment or decision-support activity?

Communicating uncertainty to policymakers is different from communicating with scientists as far as the content and the form of presentation is concerned. Knowing the target audience and what matters to them is therefore important. Further, the policy relevance of information about specific types of uncertainty depends on the phase of the policy cycle. Early on, the focus would likely be on the nature and causes of a problem, while, later the focus may shift to the effects and costs of intervention options (Kloprogge et al., 2007).

It is important to adopt a systematic approach of providing information, e.g., through ‘Progressive Disclosure of Information’ (PDI; Kloprogge et al., 2007). Under this approach a report and associated publications are subdivided into several ‘layers’. The ‘Outer’ layer forms the press releases, executive summaries, etc. Here, it is advisable that non-technical information be presented with uncertainties integrated into the main messages with the context emphasised. An example is how the significance and the consequences of the assessment findings were emphasized by IPCC in summaries for policy makers. Further, the ‘Inner’ layers comprising of appendices, background reports, etc. can provide detailed technical information, elaborate uncertainties separately emphasising on the types, sources and extent of uncertainty. With regard to any of these layers, when writing, bear in mind: the purpose of the layer, the purpose of uncertainty communication within it, the information needs of the target group, the target group’s expected attention for the layer. It is desirable that the target community’s views are canvassed while designing the scenarios and recommendation: as to what level of uncertainty is acceptable, both to the target community and scientifically.

4.7 Ways forward in biodiversity and ecosystem modelling

Modelling allows policy makers to assess the implications of scenarios of drivers and policy options on the future of biodiversity and ecosystems (Pereira et al., 2010). A diverse range of modelling approaches from local to global scales, from individual to ecosystem levels, have been developed to assess the impacts of direct drivers on biodiversity and ecosystem functioning and to investigate the feedback effects of biodiversity on these drivers. However, there still remain important challenges in the link between biodiversity modelling and policy making due to model complexity, uncertainty, and the lack of available data and knowledge (Mouquet et al., 2015).

Despite the availability of modelling approaches and applications developed in recent years, the biodiversity community needs to develop a common roadmap to better integrate predictive modelling into the challenges and needs derived from the current biodiversity crisis. A good example is from climate change research, where Global

Circulation Models and Earth System Models have helped significantly in advancing understanding of the role of greenhouse gas emission in driving the future climate.

Petchey et al. (2015) have introduced a road map for ecological predictability research. The roadmap describes the feedbacks and interactions among fundamental research in which the models are based, the data feeding such models, and the use of model outputs that operate in the process of making models that can make accurate and useful predictions. These feedbacks and interactions point to the need for an integrated approach to making models that meet the predictive requirements of stakeholders and policy (Figure 4.10).

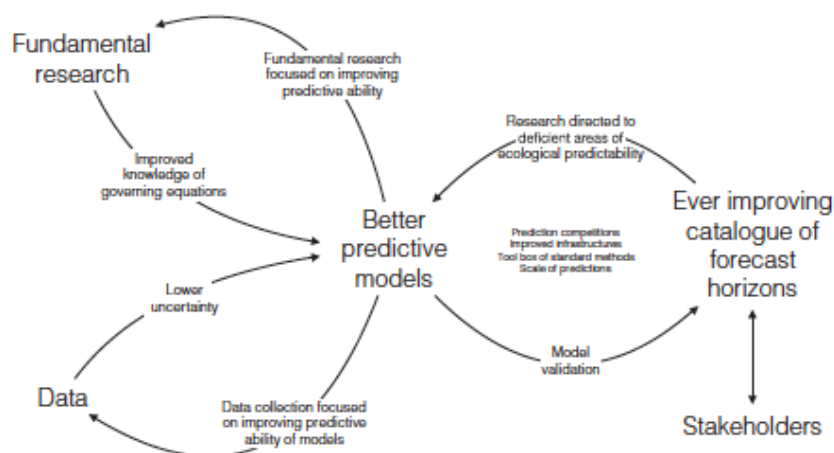

Figure 4.10: Schematic outline for improving model predictability in ecological research. The indirect interactions and feedbacks (e.g., between fundamental research and data, predictive models) are left implicit, yet are extremely important. (Source: Petchey et al., 2015).

IPBES needs to recognise the complexities linking drivers of environmental change to biodiversity and ecosystem dynamics, and acknowledge the value of modelling as a method to produce formal abstraction of such complexity and as a scientific tool for supporting decision-making. When adequately framed, modelling approaches can be used for robust policy support (Guisan et al., 2013). However, IPBES needs also to keep in mind significant capacity constraints and important gaps in the formalisation of the links between ecosystem models and policy making. Therefore, future efforts should strongly encourage stakeholder participation as early as possible. This should be done to maximise the correspondence between the assessment objectives and the outputs and limitations of the modelling approaches (Guillera Arroita et al., 2015). Further, the contextual interpretation of the modelling results and model uncertainty needs to be a joint activity of modellers and decision makers.

Finally, biodiversity and ecosystem modelling urgently requires adequate guidance regarding the typology of models used in isolation or combined in each of the assessments. Model inter-comparison programmes should lead to increased collaboration among modelling groups and also with field ecologists to develop suitable protocols for modelling impacts of drivers on biodiversity and ecosystem functions such as scale, timeframe, data collection and validation protocols, agreed processes, uncertainty analysis, and standardized outputs of the modelling studies. Promotion of model inter comparison groups will be vital for developing consistent protocols, standardized data, parameters, and scenarios, incorporating long-term observation data and for addressing and communicating uncertainty.

References

- Ackerman, F., Stanton, E.A. and Bueno, R., 2010: Fat tails, exponents, extreme uncertainty: Simulating catastrophe in DICE. *Ecological Economics*, **69**(8): 1657-1665.
- Aguirre-Gutiérrez, J., Carvalheiro, L.G., Polce, C., van Loon, E.E., Raes, N., Reemer, M. and Biesmeijer, J.C., 2013: Fit-for-Purpose: Species Distribution Model Performance Depends on Evaluation Criteria – Dutch Hoverflies as a Case Study. *PLoS ONE*, **8**(5): e63708.
- Ahrens, R.N.M., Walters, C.J. and Christensen, V., 2012: Foraging arena theory. *Fish and Fisheries*, **13**: 41-59.
- Aizpurua, O., Cantú Salazar, L., San Martín, G., Biver, G., Brotons, L. and Titeux, N., 2015: Reconciling expert judgement and habitat suitability models as tools for guiding sampling of threatened species. *Journal of Applied Ecology*: in press-n/a.
- Akçakaya, H.R. and Sjögren-Gulve, P., 2000: Population viability analyses in conservation planning: an overview. *Ecological Bulletins*.
- Akçakaya, H.R., Radeloff, V.C., Mladenoff, D.J. and He, H.S., 2004: Integrating landscape and metapopulation modeling approaches: Viability of the sharp-tailed grouse in a dynamic landscape. *Conservation Biology*, **18**(2): 526-537.
- Albouy, C., Velez, L., Coll, M., Colloca, F., Le Loc'h, F., Mouillot, D. and Gravel, D., 2014: From projected species distribution to food-web structure under climate change. *Global Change Biology*, **20**(3): 730-741.
- Allouche, O., Kalyuzhny, M., Moreno-Rueda, G., Pizarro, M. and Kadmon, R., 2012: Area-heterogeneity tradeoff and the diversity of ecological communities. *PNAS*, **109**(43): 17495-17500.
- Araújo, M.B. and Pearson, R.G., 2005: Equilibrium of species' distributions with climate. *Ecography*, **28**(5): 693-695.
- Araújo, M.B. and Peterson, A.T., 2012: Uses and misuses of bioclimatic envelope modeling. *Ecology*, **93**(7): 1527-1539.
- Araújo, M.B., Alagador, D., Cabeza, M., Nogués Bravo, D. and Thuiller, W., 2011: Climate change threatens European conservation areas. *Ecology Letters*, **14**(5): 484-492.
- Arrhenius, O., 1921: Species and Area. *The Journal of Ecology*, **9**(1): 95-99.
- Baird, D.J., Rubach, M.N. and Van den Brink, P.J., 2008: Trait-based ecological risk assessment (TERA): the new frontier? *Integrated Environmental Assessment and Management*, **4**(1): 2-3.
- Barfield, M., Holt, R.D. and Gomulkiewicz, R., 2011: Evolution in stage-structured populations. *The American Naturalist*.
- Barton, N.H., 2001: The role of hybridization in evolution. *Molecular Ecology*, **10**(3): 551-568.
- Barton, N.H. and Turelli, M., 1989: Evolutionary Quantitative Genetics: How Little Do We Know? *Annual Review of Genetics*, **23**(1): 337-370.
- Bascompte, J., Melián, C.J. and Sala, E., 2005: Interaction strength combinations and the overfishing of a marine food web. *Proceedings of The National Academy of Sciences of the United States of America*, **102**(15): 5443-5447.
- Beale, C.M. and Lennon, J.J., 2011: Incorporating uncertainty in predictive species distribution modelling. *Philosophical Transactions of the Royal Society of London. B, Biological Sciences*, **367**(1586): 247-258.
- Beissinger, S.R. and McCullough, D.R., 2002: *Population Viability Analysis*. Chicago, University of Chicago Press.
- Bell, G., 2013: Evolutionary rescue and the limits of adaptation. *Philosophical Transactions of the Royal Society of London. B, Biological Sciences*, **368**(1610): 20120080.
- Bell, G. and Collins, S., 2008: Adaptation, extinction and global change. *Evolutionary Applications*, **1**(1): 3-16.
- Bellard, C., Leclerc, C. and Courchamp, F., 2015: Combined impacts of global changes on biodiversity across the USA. *Scientific Reports*, **5**: 11828.
- Bellard, C., Bertelsmeier, C., Leadley, P., Thuiller, W. and Courchamp, F., 2012: Impacts of climate change on the future of biodiversity. *Ecology Letters*, **15**(4): 365-377.
- Berkeley, S.A., Hixon, M.A., Larson, R.J. and Love, M.S., 2004: Fisheries sustainability via protection of age structure and spatial distribution of fish populations. *Fisheries*, **29**(8): 23-32.
- Berkes, F., Folke, C. and Gadgil, M., 1995: Traditional Ecological Knowledge, Biodiversity, Resilience and Sustainability. In *Biodiversity Conservation*, Perrings, C.A., Mäler, K.G., Folke, C., Holling, C.S. and Jansson, B.O., eds., Dordrecht, Springer Netherlands, 281-299.

- Blanchard, J.L., Andersen, K.H., Scott, F., Hintzen, N.T., Piet, G. and Jennings, S., 2014: Evaluating targets and trade-offs among fisheries and conservation objectives using a multispecies size spectrum model. *Journal of Applied Ecology*, **51**(3): 612-622.
- Botkin, D.B., 1993: *Forest dynamics: An Ecological Model*. Oxford, Oxford University Press.
- Brooks, T.M., Pimm, S.L. and Collar, N.J., 1997: Deforestation Predicts the Number of Threatened Birds in Insular Southeast Asia. *Conservation Biology*, **11**(2): 382-394.
- Brooks, T.M., Mittermeier, R.A., Mittermeier, C.G., da Fonseca, G.A.B., Rylands, A.B., Konstant, W.R., Flick, P., Pilgrim, J., Oldfield, S., Magin, G. and Hilton-Taylor, C., 2002: Habitat loss and extinction in the hotspots of biodiversity. *Conservation Biology*, **16**(4): 909-923.
- Brotons, L., 2014: Species Distribution Models and Impact Factor Growth in Environmental Journals: Methodological Fashion or the Attraction of Global Change Science. *PLoS ONE*, **9**(11): e111996.
- Brotons, L., Aquilué, N., de Cáceres, M., Fortin, M.-J. and Fall, A., 2013: How Fire History, Fire Suppression Practices and Climate Change Affect Wildfire Regimes in Mediterranean Landscapes. *PLoS ONE*, **8**(5): e62392.
- Bürger, R., 2000: *The mathematical theory of selection, recombination, and mutation*. Chichester, England, Wiley.
- Bürger, R. and Lynch, M., 1995: Evolution and Extinction in a Changing Environment: A Quantitative-Genetic Analysis. *Evolution*, **49**(1): 151.
- Burgman, M., 2005: *Risks and Decisions for Conservation and Environmental Management*. Cambridge, Cambridge University Press.
- Cabral, J.S. and Schurr, F.M., 2010: Estimating demographic models for the range dynamics of plant species. *Global Ecology and Biogeography*, **19**(1): 85-97.
- Cardinale, B.J., Wright, J.P., Cadotte, M.W., Carroll, I.T., Hector, A., Srivastava, D.S., Loreau, M. and Weis, J.J., 2007: Impacts of plant diversity on biomass production increase through time because of species complementarity. *Proceedings of The National Academy of Sciences*, **104**(46): 18123-18128.
- Cardinale, B.J., Duffy, J.E., Gonzalez, A., Hooper, D.U., Perrings, C., Venail, P., Narwani, A., Mace, G.M., Tilman, D., Wardle, D.A., Kinzig, A.P., Daily, G.C., Loreau, M., Grace, J.B., Larigauderie, A., Srivastava, D.S. and Naeem, S., 2012: Biodiversity loss and its impact on humanity. *Nature*, **486**(7401): 59-67.
- Carlson, S.M., Cunningham, C.J. and Westley, P.A.H., 2014: Evolutionary rescue in a changing world. *Trends in Ecology and Evolution*, **29**(9): 521-530.
- Chapin, F.S., Zavaleta, E.S., Eviner, V.T., Naylor, R.L., Vitousek, P.M., Reynolds, H.L., Hooper, D.U., Lavorel, S., Sala, O.E., Hobbie, S.E., Mack, M.C. and Díaz, S., 2000: Consequences of changing biodiversity. *Nature*, **405**(6783): 234-242.
- Cheung, W.W.L., Lam, V.W.Y. and Pauly, D., 2008a: Modelling Present and Climate-shifted Distributions of Marine Fishes and Invertebrates. Fisheries Centre. University of British Columbia, Fisheries Centre Research Report 16(3),
- Cheung, W.W.L., Lam, V. and Pauly, D., 2008b: Dynamic bioclimate envelope model to predict climate-induced changes in distributions of marine fishes and invertebrates. Fisheries Centre, University of British Columbia, Modelling present and climate-shifted distributions of marine fishes and invertebrates., Vancouver.
- Cheung, W.W.L., Dunne, J., Sarmiento, J.L. and Pauly, D., 2011: Integrating ecophysiology and plankton dynamics into projected maximum fisheries catch potential under climate change in the Northeast Atlantic. *ICES Journal of Marine Science*, **68**(6): 1008-1018.
- Chisholm, R.A. and Wintle, B.A., 2007: Incorporating landscape stochasticity into population viability analysis. *Ecological Applications*, **17**(2): 317-322.
- Christensen, V. and Walters, C.J., 2011: Progress in the use of ecosystem modeling for fisheries management. In *Ecosystem Approaches to Fisheries: A Global Perspective*, Christensen, V. and Maclean, J.L., eds., Cambridge, Cambridge University Press, 189-205.
- Christensen, V., Coll, M., Steenbeek, J., Buszowski, J., Chagaris, D. and Walters, C.J., 2014: Representing Variable Habitat Quality in a Spatial Food Web Model. *Ecosystems*, **17**(8): 1397-1412.
- Collie, J.S., Botsford, L.W., Hastings, A., Kaplan, I.C., Largier, J.L., Livingston, P.A., Plagányi, É., Rose, K.A., Wells, B.K. and Werner, F.E., 2014: Ecosystem models for fisheries management: finding the sweet spot. *Fish and Fisheries*.

- Concepción, E.D. and Díaz, M., 2011: Field, landscape and regional effects of farmland management on specialist open-land birds: Does body size matter? *Agriculture, Ecosystems & Environment*, **142**(3-4): 303-310.
- Cramer, W., Bondeau, A., Woodward, F.I., Prentice, I.C., Betts, R.A., Brovkin, V., Cox, P.M., Fisher, V., Foley, J.A., Friend, A.D., Kucharik, C., Lomas, M.R., Ramankutty, N., Sitch, S., Smith, B., White, A. and Young Molling, C., 2001: Global response of terrestrial ecosystem structure and function to CO₂ and climate change: results from six dynamic global vegetation models. *Global Change Biology*, **7**(4): 357-373.
- Cuddington, K., Fortin, M.J., Gerber, L.R., Hastings, A., Liebhold, A., O'Connor, M.I. and Ray, C., 2013: Process-based models are required to manage ecological systems in a changing world. *Ecosphere*, **4**(2): 20.
- D'Amen, M., Rahbek, C., Zimmermann, N.E. and Guisan, A., 2015: Spatial predictions at the community level: from current approaches to future frameworks. *Biological Reviews*, **Early view**.
- Dale, V.H. and Beyeler, S.C., 2001: Challenges in the development and use of ecological indicators. *Ecological Indicators*, **1**(1): 3-10.
- Davis, A.J., Jenkinson, L.S., Lawton, J.H., Shorrocks, B. and Wood, S., 1998: Making mistakes when predicting shifts in species range in response to global warming. *Nature*, **391**(6669): 783-786.
- de Souza Muñoz, M.E., De Giovanni, R., de Siqueira, M.F., Sutton, T., Brewer, P., Pereira, R.S., Canhos, D.A.L. and Canhos, V.P., 2011: openModeller: a generic approach to species' potential distribution modelling. *GeoInformatica*, **15**(1): 111-135.
- de Vladar, H.P. and Barton, N., 2014: Stability and response of polygenic traits to stabilizing selection and mutation. *Genetics*, **197**(2): 749-767.
- del Barrio, G., Harrison, P.A., Berry, P.M., Butt, N., Sanjuan, M.E., Pearson, R.G. and Dawson, T., 2006: Integrating multiple modelling approaches to predict the potential impacts of climate change on species' distributions in contrasting regions: comparison and implications for policy. *Environmental Science & Policy*, **9**(2): 129-147.
- Desrochers, R.E. and Kerr, J.T., 2011: How, and how much, natural cover loss increases species richness. *Global Ecology and Biogeography*, **20**(6): 857-867.
- Dormann, C.F., Schymanski, S.J., Cabral, J., Chuine, I., Graham, C., Hartig, F., Kearney, M., Morin, X., Römermann, C., Schröder, B. and Singer, A., 2012: Correlation and process in species distribution models: bridging a dichotomy. *Journal of Biogeography*, **39**(12): 2119-2131.
- Drakare, S., Lennon, J.J. and Hillebrand, H., 2006: The imprint of the geographical, evolutionary and ecological context on species-area relationships. *Ecology Letters*, **9**(2): 215-227.
- Drechsler, M. and Burgman, M.A., 2004: Combining population viability analysis with decision analysis. *Biodiversity and Conservation*, **13**: 115-139.
- Dunford, R., Harrison, P.A. and Rounsevell, M.D.A., 2014: Exploring scenario and model uncertainty in cross-sectoral integrated assessment approaches to climate change impacts. *Climatic Change*, **132**(3): 417-432.
- Duplisea, D.E., Jennings, S., Warr, K.J. and Dinmore, T.A., 2002: A size-based model of the impacts of bottom trawling on benthic community structure. *Canadian Journal of Fisheries and Aquatic Sciences*, **59**(11): 1785-1795.
- Duputié, A., Massol, F., Chuine, I., Kirkpatrick, M. and Ronce, O., 2012: How do genetic correlations affect species range shifts in a changing environment? *Ecology Letters*, **15**(3): 251-259.
- Ehrlén, J. and Morris, W.F., 2015: Predicting changes in the distribution and abundance of species under environmental change. *Ecology Letters*, **18**(3): 303-314.
- Eldridge, D.J. and Freudenberger, D., 2005: Ecosystem wicks: woodland trees enhance water infiltration in a fragmented agricultural landscape in eastern Australia. *Austral Ecology*, **30**(3): 336-347.
- Elith, J. and Graham, C.H., 2009: Do they? How do they? WHY do they differ? On finding reasons for differing performances of species distribution models. *Ecography*, **32**(1): 66-77.
- Elith, J. and Leathwick, J.R., 2009: Species distribution models: ecological explanation and prediction across space and time. *Annual Review of Ecology Evolution and Systematics* **40**: 677-697.
- Elith, J., Kearney, M. and Phillips, S., 2010: The art of modelling range-shifting species. *Methods in Ecology and Evolution*, **1**(4): 330-342.
- FAO, 2008: Fisheries management. 2. The ecosystem approach to fisheries. 2.1 Best practices in ecosystem modelling for informing an ecosystem approach to fisheries. FAO Fisheries, Technical Guidelines for Responsible Fisheries, Rome.

- Fernandes, P.G. and Cook, R.M., 2013: Reversal of fish stock decline in the Northeast Atlantic. *Current Biology*, **23**(15): 1432-1437.
- Ferrier, S. and Guisan, A., 2006: Spatial modelling of biodiversity at the community level. *Journal of Applied Ecology*, **43**: 393-404.
- Ferrier, S., Drielsma, M., Manion, G. and Watson, G., 2002a: Extended statistical approaches to modelling spatial pattern in biodiversity in northeast New South Wales. II. Community-level modelling. *Biodiversity and Conservation*, **11**: 2309-2338.
- Ferrier, S., Watson, G., Pearce, J. and Drielsma, M., 2002b: Extended statistical approaches to modelling spatial pattern in biodiversity in northeast New South Wales. I. Species-level modelling. *Biodiversity and Conservation*, **11**(12): 2275-2307.
- Foley, J.A., Levis, S., Costa, M.H., Cramer, W. and Pollard, D., 2000: Incorporating dynamic vegetation cover within global climate models. *Ecological Applications*, **10**(6): 1620-1632.
- Foley, J.A., Prentice, I.C., Ramankutty, N., Levis, S., Pollard, D., Sitch, S. and Haxeltine, A., 1996: An integrated biosphere model of land surface processes, terrestrial carbon balance, and vegetation dynamics. *Global Biogeochemical Cycles*, **10**(4): 603-628.
- Fulton, E., Smith, A. and Johnson, C., 2003: Effect of complexity on marine ecosystem models. *Marine Ecology Progress Series*, **253**(1): 16.
- Fung, T., Farnsworth, K.D., Reid, D.G. and Rossberg, A.G., 2015: Impact of biodiversity loss on production in complex marine food webs mitigated by prey-release. *Nature Communications*, **6**: 6657.
- Gadgil, M., Berkes, F. and Folke, C., 1993: Indigenous Knowledge for Biodiversity Conservation. *AMBIO: A journal of the human environment*, **22**(2-3): 151-156.
- Gaikwad, J., Wilson, P.D. and Ranganathan, S., 2011: Ecological niche modeling of customary medicinal plant species used by Australian Aborigines to identify species-rich and culturally valuable areas for conservation. *Ecological Modelling*, **222**(18): 3437-3443.
- Gallego-Sala, A.V., Clark, J.M., House, J.I., Orr, H.G., Prentice, I.C., Smith, P., Farewell, T. and Chapman, S.J., 2010: Bioclimatic envelope model of climate change impacts on blanket peatland distribution in Great Britain. *Climate Research*, **45**(1): 151-162.
- Gallien, L., Münkemüller, T., Albert, C.H., Boulangeat, I., Boulangeat, I. and Thuiller, W., 2010: Predicting potential distributions of invasive species: where to go from here? *Diversity and Distributions*, **16**: 331-342.
- Getz, W.M., 1988: Harvesting discrete nonlinear age and stage structured populations. *Journal of Optimization Theory and Applications*, **57**(1): 69-83.
- Giordano, F.R., Weir, M.D. and Fox, W.P., 2003: *A First Course in Mathematical Modeling*. California, Brooks Cole.
- Gomulkiewicz, R. and Houle, D., 2009: Demographic and Genetic Constraints on Evolution. *American Naturalist*, **174**(6): E218-E229.
- Gomulkiewicz, R., Holt, R.D. and Barfield, M., 1999: The effects of density dependence and immigration on local adaptation and niche evolution in a black-hole sink environment. *Theoretical Population Biology*, **55**: 285-296.
- Goodess, C.M., Hanson, C., Hulme, M. and Osborn, T.J., 2003: Representing climate and extreme weather events in integrated assessment models: a review of existing methods and options for development. *Integrated Assessment*, **4**(3): 145-171.
- Gotelli, N.J., 2008: *A Primer of Ecology*. Sunderland, MA, USA, Sinauer Associates.
- Gould, S.F., Beeton, N.J., Harris, R.M.B., Hutchinson, M.F., Lechner, A.M., Porfirio, L.L. and Mackey, B.G., 2014: A tool for simulating and communicating uncertainty when modelling species distributions under future climates. *Ecology and Evolution*, **4**(24): 4798-4811.
- Grimm, V., Revilla, E., Berger, U., Jeltsch, F., Mooij, W.M., Railsback, S.F., Thulke, H.H., Weiner, J., Wiegand, T. and DeAngelis, D.L., 2005: Pattern-oriented modeling of agent-based complex systems: Lessons from ecology. *Science*, **310**(5750): 987-991.
- Guilhaumon, F., Gimenez, O., Gaston, K.J. and Mouillot, D., 2008: Taxonomic and regional uncertainty in species-area relationships and the identification of richness hotspots. *Proceedings of The National Academy of Sciences*, **105**(40): 15458-15463.

- Guillera Arroita, G., Lahoz Monfort, J.J., Elith, J., Gordon, A., Kujala, H., Lentini, P.E., McCarthy, M.A., Tingley, R. and Wintle, B.A., 2015: Is my species distribution model fit for purpose? Matching data and models to applications. *Global Ecology and Biogeography*, **24**(3): 276-292.
- Guisan, A. and Thuiller, W., 2005: Predicting species distribution: offering more than simple habitat models. *Ecology Letters*, **8**(9): 993-1009.
- Guisan, A., Tingley, R., Baumgartner, J.B., Naujokaitis Lewis, I., Sutcliffe, P.R., Tulloch, A.I.T., Regan, T.J., Brotons, L., McDonald Madden, E., Mantyka Pringle, C., Martin, T.G., Rhodes, J.R., Maggini, R., Setterfield, S.A., Elith, J., Schwartz, M.W., Wintle, B.A., Broennimann, O., Austin, M., Ferrier, S., Kearney, M.R., Possingham, H.P. and Buckley, Y.M., 2013: Predicting species distributions for conservation decisions. *Ecology Letters*, **16**(12): 1424-1435.
- Gustafson, E.J., 2013: When relationships estimated in the past cannot be used to predict the future: using mechanistic models to predict landscape ecological dynamics in a changing world. *Landscape Ecology*, **28**(8): 1429-1437.
- Handa, I.T., Aerts, R., Berendse, F., Berg, M.P., Bruder, A., Butenschoten, O., Chauvet, E., Gessner, M.O., Jabiol, J., Makkonen, M., McKie, B.G., Malmqvist, B., Peeters, E.T.H.M., Scheu, S., Schmid, B., van Ruijven, J., Vos, V.C.A. and Hättenschwiler, S., 2014: Consequences of biodiversity loss for litter decomposition across biomes. *Nature*, **509**(7499): 218-221.
- Hanski, I., Zurita, G.A., Bellocq, M.I. and Rybicki, J., 2013: Species-fragmented area relationship. *Proceedings of The National Academy of Sciences*, **110**(31): 12715-12720.
- Harfoot, M., Tittensor, D.P., Newbold, T., McInerney, G., Smith, M.J. and Scharlemann, J.P.W., 2014a: Integrated assessment models for ecologists: the present and the future. *Global Ecology and Biogeography*, **23**(2): 124-143.
- Harfoot, M.B.J., Newbold, T., Tittensor, D.P., Emmott, S., Hutton, J., Lyutsarev, V., Smith, M.J., Scharlemann, J.P.W. and Purves, D.W., 2014b: Emergent Global Patterns of Ecosystem Structure and Function from a Mechanistic General Ecosystem Model. *PLoS Biology*, **12**(4): e1001841.
- Harremoes, P. and Turner, R.K., 2001: Methods for integrated assessment. *Regional Environmental Change*, **2**(2): 57-65.
- Harrison, P.A., Holman, I.P. and Berry, P.M., 2015: Assessing cross-sectoral climate change impacts, vulnerability and adaptation: an introduction to the CLIMSAVE project. *Climatic Change*, **128**(3-4): 153-167.
- Harrison, P.A., Berry, P.M., Simpson, G. and Haslett, J.R., 2014: Linkages between biodiversity attributes and ecosystem services: A systematic review. *Ecosystem Services*, **9**: 191-203.
- Hilbert, D.W. and Ostendorf, B., 2001: The utility of artificial neural networks for modelling the distribution of vegetation in past, present and future climates. *Ecological Modelling*, **146**: 311-327.
- Hilborn, R. and Walters, C.J., 1992: *Quantitative Fisheries Stock Assessment: Choice, Dynamics, and Uncertainty*. Dordrecht, Chapman and Hall.
- Hoffmann, A.A. and Sgrò, C.M., 2011: Climate change and evolutionary adaptation. *Nature*, **470**: 479-485.
- Holling, C.S., 1959: Some characteristics of simple types of predation and parasitism. *Canadian Entomologist*, **91**: 385-398.
- Hooper, D.U., Iii, F.S.C., Ewel, J.J. and Hector, A., 2005: Effects of biodiversity on ecosystem functioning: a consensus of current knowledge. *Ecological Monographs*, **75**(1): 3-35.
- Hope, C., 2013: Critical issues for the calculation of the social cost of CO2: why the estimates from PAGE09 are higher than those from PAGE2002. *Climatic Change*, **117**(3): 531-543.
- Hui, C., Krug, R.M. and Richardson, D.M., 2010: Modelling Spread in Invasion Ecology: A Synthesis. In *Fifty Years of Invasion Ecology*, Wiley-Blackwell, 329-343.
- Huth, N. and Possingham, H.P., 2011: Basic ecological theory can inform habitat restoration for woodland birds. *Journal of Applied Ecology*, **48**(2): 293-300.
- Iglecia, M.N., Collazo, J.A. and McKerrow, A.J., 2012: Use of occupancy models to evaluate expert knowledge-based species-habitat. *Avian Conservation and Ecology*, **7**(2): 5.
- Ings, T.C., Montoya, J.M., Bascompte, J., Blüthgen, N., Brown, L., Dormann, C.F., Edwards, F., Figueroa, D., Jacob, U., Jones, J.I., Lauridsen, R.B., Ledger, M.E., Lewis, H.M., Olesen, J.M., Van Veen, F.J.F., Warren, P.H. and Woodward, G., 2009: Review: Ecological networks – beyond food webs. *Journal of Animal Ecology*, **78**(1): 253-269.

- IPCC, 2001: IPCC Third Assessment Report. IPCC,
- Isbell, F., Calcagno, V., Hector, A., Connolly, J., Harpole, W.S., Reich, P.B., Scherer-Lorenzen, M., Schmid, B., Tilman, D., van Ruijven, J., Weigelt, A., Wilsey, B.J., Zavaleta, E.S. and Loreau, M., 2011: High plant diversity is needed to maintain ecosystem services. *Nature*, **477**(7363): 199-202.
- Iverson, L.R. and Prasad, A.M., 2001: Potential changes in tree species richness and forest community types following climate change. *Ecosystems*, **4**(3): 186-199.
- Ives, A.R., Dennis, B., Cottingham, K.L. and Carpenter, S.R., 2003: Estimating community stability and ecological interactions from time-series data. *Ecological Monographs*, **73**(2): 301-330.
- Janse, J.H., Kuiper, J.J., Weijters, M.J., Westerbeek, E.P., Jeuken, M.H.J.L., Bakkenes, M., Alkemade, R., Mooij, W.M. and Verhoeven, J.T.A., 2015: GLOBIO-Aquatic, a global model of human impact on the biodiversity of inland aquatic ecosystems. *Environmental Science & Policy*, **48**: 99-114.
- Janssen, J.A.E.B., Krol, M.S., Schielen, R.M.J., Hoekstra, A.Y. and de Kok, J.L., 2010: Assessment of uncertainties in expert knowledge, illustrated in fuzzy rule-based models. *Ecological Modelling*, **221**(9): 1245-1251.
- Jennings, S., Pinnegar, J.K., Polunin, N.V.C. and Boon, T.W., 2001: Weak cross-species relationships between body size and trophic level belie powerful size-based trophic structuring in fish communities. *Journal of Animal Ecology*, **70**(6): 934-944.
- Jørgensen, S.E. and Bendoricchio, G., 2001: *Fundamentals of Ecological Modelling*. Amsterdam, Elsevier.
- Kearney, M.R., Wintle, B.A. and Porter, W.P., 2010: Correlative and mechanistic models of species distribution provide congruent forecasts under climate change. *Conservation Letters*, **3**(3): 203-213.
- Klopprogge, P., van der Sluijs, J. and Wardekker, A., 2007: Uncertainty Communication Issues and good practice. Copernicus Institute for Sustainable Development and Innovation Department of Science Technology and Society (STS), Utrecht, The Netherlands.
- Kooijman, S.A.L.M., 2009: *Dynamic energy budget theory for metabolic organization*. Cambridge, U.K., Cambridge University Press.
- Kritzer, J.P. and Sale, P.F., 2010: *Marine metapopulations*. Elsevier Academic Press.
- Kucharik, C.J., Foley, J.A., Delire, C., Fisher, V.A., Coe, M.T., Lenters, J.D., Young Molling, C., Ramankutty, N., Norman, J.M. and Gower, S.T., 2000: Testing the performance of a dynamic global ecosystem model: Water balance, carbon balance, and vegetation structure. *Global Biogeochemical Cycles*, **14**(3): 795-825.
- Kuhnert, P.M., Martin, T.G. and Griffiths, S.P., 2010: A guide to eliciting and using expert knowledge in Bayesian ecological models. *Ecology Letters*, **13**(7): 900-914.
- Kunstler, G., Albert, C.H., Courbaud, B., Lavergne, S., Thuiller, W., Vieilledent, G., Zimmermann, N.E. and Coomes, D.A., 2011: Effects of competition on tree radial-growth vary in importance but not in intensity along climatic gradients. *Journal of Ecology*, **99**(1): 300-312.
- Lande, R. and Arnold, S.J., 1983: The measurement of selection on correlated characters. *Evolution*, **37**(6): 1210-1226.
- Lande, R. and Shannon, S., 1996: The Role of Genetic Variation in Adaptation and Population Persistence in a Changing Environment. *Evolution*, **50**(1): 434-437.
- Larson, M.A., Thompson Iii, F.R., Millspaugh, J.J., Dijak, W.D. and Shifley, S.R., 2004: Linking population viability, habitat suitability, and landscape simulation models for conservation planning. *Ecological Modelling*, **180**(1): 103-118.
- Lavergne, S., Mouquet, N., Thuiller, W. and Ronce, O., 2010: Biodiversity and Climate Change: Integrating Evolutionary and Ecological Responses of Species and Communities. *Annual Review of Ecology, Evolution, and Systematics*, **41**(1): 321-350.
- Lavorel, S. and Garnier, E., 2002: Predicting changes in community composition and ecosystem functioning from plant traits: revisiting the Holy Grail. *Functional Ecology*, **16**(5): 545-556.
- Lenton, T.M., 2011: Early warning of climate tipping points. *Nature Climate Change*, **1**(4): 201-209.
- Leung, B., Roura Pascual, N., Bacher, S., Heikkilä, J., Brotons, L., Burgman, M.A., Dehnen Schmutz, K., Essl, F., Hulme, P.E., Richardson, D.M., Sol, D. and Vilà, M., 2012: TEASing apart alien species risk assessments: a framework for best practices. *Ecology Letters*, **15**(12): 1475-1493.

- Link, J.S., Ihde, T.F., Harvey, C.J., Gaichas, S.K., Field, J.C., Brodziak, J.K.T., Townsend, H.M. and Peterman, R.M., 2012: Dealing with uncertainty in ecosystem models: The paradox of use for living marine resource management. *Progress in Oceanography*, **102**: 102-114.
- Loreau, M., 2010: *From Populations to Ecosystems*. Princeton University Press.
- Loreau, M., Mouquet, N. and Gonzalez, A., 2003: Biodiversity as spatial insurance in heterogeneous landscapes. *Proceedings of The National Academy of Sciences of the United States of America*, **100**(22): 12765-12770.
- Loreau, M., Naeem, S., Inchausti, P., Bengtsson, J., Grime, J.P., Hector, A., Hooper, D.U., Huston, M.A., Raffaelli, D., Schmid, B., Tilman, D. and Wardle, D.A., 2001: Biodiversity and ecosystem functioning: current knowledge and future challenges. *Science*, **294**(5543): 804-808.
- Lurgi, M., Brook, B.W., Saltré, F. and Fordham, D.A., 2015: Modelling range dynamics under global change: which framework and why? *Methods in Ecology and Evolution*, **6**(3): 247-256.
- MA, 2005a: *Ecosystems and human well-being: Biodiversity synthesis*. Washington, D.C., World Resources Institute.
- MA, 2005b: *Ecosystems and Human Well-being: Synthesis*. Washington, DC, Island Press.
- Mace, G.M., Norris, K. and Fitter, A.H., 2012: Biodiversity and ecosystem services: a multilayered relationship. *Trends in Ecology & Evolution*, **27**(1): 19-26.
- MacMillan, D.C. and Marshall, K., 2006: The Delphi process—an expert-based approach to ecological modelling in data-poor environments. *Animal Conservation*, **9**(1): 11-19.
- Magga, O.H., Mathiesen, S.D., Corell, R.W. and Oskal, A., 2011: Reindeer Herding, Traditional Knowledge and Adaptation to Climate Change and Loss of Grazing Land. Association of World Reindeer Herders, Kautokeino.
- Malcolm, J.R., Liu, C., Neilson, R.P., Hansen, L. and Hannah, L., 2006: Global Warming and Extinctions of Endemic Species from Biodiversity Hotspots. *Conservation Biology*, **20**(2): 538-548.
- Marten, A.L., Kopp, R.E., Shouse, K.C., Griffiths, C.W., Hodson, E.L., Kopits, E., Mignone, B.K., Moore, C., Newbold, S.C., Waldhoff, S. and Wolverton, A., 2012: Improving the assessment and valuation of climate change impacts for policy and regulatory analysis. *Climatic Change*, **117**(3): 433-438.
- Martin, T.G., Burgman, M.A., Fidler, F., Kuhnert, P.M., Low Choy, S., McBride, M. and Mengersen, K., 2012: Eliciting Expert Knowledge in Conservation Science. *Conservation Biology*, **26**(1): 29-38.
- McElhany, P., Steel, E.A., Avery, K. and Yoder, N., 2010: Dealing with uncertainty in ecosystem models: lessons from a complex salmon model. *Ecological Monographs*, **20**(2): 465-482.
- McInerney, G.J. and Etienne, R.S., 2012: Ditch the niche – is the niche a useful concept in ecology or species distribution modelling? *Journal of Biogeography*, **39**(12): 2096-2102.
- McRae, B.H., Dickson, B.G., Keitt, T.H. and Shah, V.B., 2008: Using circuit theory to model connectivity in ecology, evolution, and conservation. *Ecology*, **89**(10): 2712-2724.
- Mellard, J.P., de Mazancourt, C. and Loreau, M., 2015: Evolutionary responses to environmental change: trophic interactions affect adaptation and persistence. *Proceedings of the Royal Society of London. Series B: Biological Sciences*, **282**(1805): 20141351.
- Merow, C., Smith, M.J., Edwards, T.C., Guisan, A., McMahon, S.M., Normand, S., Thuiller, W., Wüest, R.O., Zimmermann, N.E. and Elith, J., 2014: What do we gain from simplicity versus complexity in species distribution models? *Ecography*, **37**(12): 1267-1281.
- Midgley, G.F., Davies, I.D., Albert, C.H., Altwegg, R., Hannah, L., Hughes, G.O., O'Halloran, L.R., Seo, C., Thorne, J.H. and Thuiller, W., 2010: BioMove – an integrated platform simulating the dynamic response of species to environmental change. *Ecography*, **33**(3): 612-616.
- Mokany, K. and Ferrier, S., 2011: Predicting impacts of climate change on biodiversity: A role for semi-mechanistic community-level modelling. *Diversity and Distributions*, **17**(2): 374-380.
- Mokany, K., Ferrier, S., Connolly, S.R., Dunstan, P.K., Fulton, E.A., Harfoot, M.B., Harwood, T.D., Richardson, A.J., Roxburgh, S.H., Scharlemann, J.P.W., Tittensor, D.P., Westcott, D.A. and Wintle, B.A., 2015: Integrating modelling of biodiversity composition and ecosystem function. *Oikos*: In Press.
- Moller, H., Berkes, F., Lyver, P.O.B. and Kislalioglu, M., 2004: Combining science and traditional ecological knowledge: monitoring populations for co-management. *Ecology and Society*, **9**(3): 2.
- Morin, X. and Lechowicz, M.J., 2008: Contemporary perspectives on the niche that can improve models of species range shifts under climate change. *Biology Letters*, **4**(5): 573-576.

- Morris, W.F. and Doak, D.F., 2002: *Quantitative Conservation Biology: Theory and Practice of Population Viability Analysis*. Sunderland, Massachusetts, USA, Sinauer Associates.
- Mouquet, N., Lagadeuc, Y., Devictor, V., Doyen, L., Duputié, A., Eveillard, D., Faure, D., Garnier, E., Gimenez, O., Huneman, P., Jabot, F., Jarne, P., Joly, D., Julliard, R., Kéfi, S., Kergoat, G.J., Lavorel, S., Le Gall, L., Meslin, L., Morand, S., Morin, X., Morlon, H., Pinay, G., Pradel, R., Schurr, F.M., Thuiller, W. and Loreau, M., 2015: REVIEW: Predictive ecology in a changing world. *Journal of Applied Ecology*, **52**(5): 1293-1310.
- Mouton, A.M., De Baets, B. and Goethals, P.L.M., 2009: Knowledge-based versus data-driven fuzzy habitat suitability models for river management. *Environmental Modelling & Software*, **24**(8): 982-993.
- Murray, J.V., Goldizen, A.W., O'Leary, R.A., McAlpine, C.A., Possingham, H.P. and Choy, S.L., 2009: How useful is expert opinion for predicting the distribution of a species within and beyond the region of expertise? A case study using brush-tailed rock-wallabies *Petrogale penicillata*. *Journal of Applied Ecology*, **46**(4): 842-851.
- Newbold, T., Hudson, L.N., Hill, S.L.L., Contu, S., Lysenko, I., Senior, R.A., Börger, L., Bennett, D.J., Choimes, A., Collen, B., Day, J., De Palma, A., Díaz, S., Echeverria-Londoño, S., Edgar, M.J., Feldman, A., Garon, M., Harrison, M.L.K., Alhusseini, T., Ingram, D.J., Itescu, Y., Kattge, J., Kemp, V., Kirkpatrick, L., Kleyer, M., Correia, D.L.P., Martin, C.D., Meiri, S., Novosolov, M., Pan, Y., Phillips, H.R.P., Purves, D.W., Robinson, A., Simpson, J., Tuck, S.L., Weiher, E., White, H.J., Ewers, R.M., Mace, G.M., Scharlemann, J.P.W. and Purvis, A., 2015: Global effects of land use on local terrestrial biodiversity. *Nature*, **520**(7545): 45-50.
- Niamir, A., Skidmore, A.K., Toxopeus, A.G., Muñoz, A.R. and Real, R., 2011: Finessing atlas data for species distribution models. *Diversity and Distributions*, **17**(6): 1173-1185.
- Noss, R.F., 1990: Indicators for Monitoring Biodiversity - a Hierarchical Approach. *Conservation Biology*, **4**(4): 355-364.
- Notaro, M., Mauss, A. and Williams, J.W., 2012: Projected vegetation changes for the American Southwest: combined dynamic modeling and bioclimatic-envelope approach. *Ecological Applications*, **22**(4): 1365-1388.
- Oliver, T.H., Heard, M.S., Isaac, N.J.B., Roy, D.B., Procter, D., Eigenbrod, F., Freckleton, R., Hector, A., Orme, C.D.L., Petchey, O.L., Proença, V., Raffaelli, D., Suttle, K.B., Mace, G.M., Martín-López, B., Woodcock, B.A. and Bullock, J.M., 2015: Biodiversity and Resilience of Ecosystem Functions. *Trends in Ecology & Evolution*, **30**(11): 673-684.
- Osmond, M.M. and de Mazancourt, C., 2013: How competition affects evolutionary rescue. *Philosophical Transactions of the Royal Society of London. B, Biological Sciences*, **368**(1610): 20120085.
- Ostberg, S., Schaphoff, S., Lucht, W. and Gerten, D., 2015: Three centuries of dual pressure from land use and climate change on the biosphere. *Environmental Research Letters*, **10**(4): 044011.
- Otto, S.P. and Day, T., 2007: *A biologist's guide to mathematical modeling in ecology and evolution*. Princeton, NJ, Princeton University Press.
- Pagel, J. and Schurr, F.M., 2012: Forecasting species ranges by statistical estimation of ecological niches and spatial population dynamics. *Global Ecology and Biogeography*, **21**(2): 293-304.
- Parrott, L., 2011: Hybrid modelling of complex ecological systems for decision support: Recent successes and future perspectives. *Ecological Informatics*, **6**(1): 44-49.
- Pausas, J.G. and Keeley, J.E., 2009: A Burning Story: The Role of Fire in the History of Life. *Bioscience*, **59**(7): 593-601.
- Pearson, R.G. and Dawson, T.P., 2003: Predicting the impacts of climate change on the distribution of species: are bioclimate envelope models useful? *Global Ecology and Biogeography*, **12**(5): 361-371.
- Pease, C.M., Lande, R. and Bull, J.J., 2008: A model of population growth, dispersal and evolution in a changing environment. *Ecology*, **70**(6): 1657-1664.
- Peppler-Lisbach, C. and Schröder, B., 2004: Predicting the species composition of *Nardus stricta* communities by logistic regression modelling. *Journal of Vegetation Science*, **15**(5): 623-634.
- Pereira, H.M. and Daily, G.C., 2006: Modeling biodiversity dynamics in countryside landscapes. *Ecology*, **25**(2): 348-360.
- Pereira, H.M., Navarro, L.M. and Martins, I.S., 2012: Global biodiversity change: the bad, the good, and the unknown. *Annual Review of Environment and Resources*, **37**(1): 25-50.
- Pereira, H.M., Leadley, P.W., Proença, V., Alkemade, R., Scharlemann, J.P.W., Fernandez-Manjarres, J.F., Araujo, M.B., Balvanera, P., Biggs, R., Cheung, W.W.L., Chini, L., Cooper, H.D., Gilman, E.L., Guénette, S., Hurtt,

- G.C., Huntington, H.P., Mace, G.M., Oberdorff, T., Revenga, C., Rodrigues, P., Scholes, R.J., Sumaila, U.R. and Walpole, M., 2010: Scenarios for Global Biodiversity in the 21st Century. *Science*, **330**(6010): 1496-1501.
- Pereira, H.M., Ferrier, S., Walters, M., Geller, G.N., Jongman, R.H.G., Scholes, R.J., Bruford, M.W., Brummitt, N., Butchart, S.H.M., Cardoso, A.C., Coops, N.C., Dulloo, E., Faith, D.P., Freyhof, J., Gregory, R.D., Heip, C., Höft, R., Hurtt, G., Jetz, W., Karp, D.S., McGeoch, M.A., Obura, D., Onoda, Y., Pettorelli, N., Reyers, B., Sayre, R., Scharlemann, J.P.W., Stuart, S.N., Turak, E., Walpole, M. and Wegmann, M., 2013: Essential Biodiversity Variables. *Science*, **339**(6117): 277-278.
- Petchey, O.L., McPhearson, P.T., Casey, T.M. and Morin, P.J., 1999: Environmental warming alters food-web structure and ecosystem function. *Nature*, **402**(6757): 69-72.
- Petchey, O.L., Pontarp, M., Massie, T.M., Kéfi, S., Ozgul, A., Weilenmann, M., Palamara, G.M., Altermatt, F., Matthews, B., Levine, J.M., Childs, D.Z., McGill, B.J., Schaepman, M.E., Schmid, B., Spaak, P., Beckerman, A.P., Pennekamp, F. and Pearse, I.S., 2015: The ecological forecast horizon, and examples of its uses and determinants. *Ecology Letters*, **18**(7): 597-611.
- Peterson, A.T., 2006: Uses and requirements of ecological niche models and related distributional models. *Biodiversity Informatics*, **3**(0): 59-72.
- Phillips, S.J., Anderson, R.P. and Schapire, R.E., 2006: Maximum entropy modeling of species geographic distributions. *Ecological Modelling*, **190**(3-4): 231-259.
- Pimm, S.L., Jenkins, C.N., Abell, R., Brooks, T.M., Gittleman, J.L., Joppa, L.N., Raven, P.H., Roberts, C.M. and Sexton, J.O., 2014: The biodiversity of species and their rates of extinction, distribution, and protection. *Science*, **344**(6187): 1246752.
- Polechová, J. and Barton, N.H., 2015: Limits to adaptation along environmental gradients. *Proceedings of The National Academy of Sciences*: 6401-6406.
- Polechová, J., Barton, N. and Marion, G., 2009: Species' Range: Adaptation in Space and Time. *American Naturalist*, **174**(5): E186-E204.
- Proença, V. and Pereira, H.M., 2013: Species–area models to assess biodiversity change in multi-habitat landscapes: The importance of species habitat affinity. *Basic And Applied Ecology*, **14**(2): 102-114.
- Pulliam, H.R., 2000: On the relationship between niche and distribution. *Ecology Letters*, **3**(4): 349-361.
- Rahbek, C., Gotelli, N.J., Colwell, R.K., Entsminger, G.L., Rangel, T.F.L.V.B. and Graves, G.R., 2007: Predicting continental-scale patterns of bird species richness with spatially explicit models. *Proceedings of the Royal Society of London. Series B: Biological Sciences*, **274**(1607): 165-174.
- Raygorodetsky, G., Why Traditional Knowledge Holds the Key to Climate Change, <http://unu.edu/publications/articles/why-traditional-knowledge-holds-the-key-to-climate-change.html>
- Rochet, M.J., Collie, J.S., Simon, J. and Hall, S.J., 2011: Does selective fishing conserve community biodiversity? Predictions from a length-based multispecies model. *Canadian Journal of Fisheries and Aquatic Sciences*, **68**(3): 469-486.
- Rondinini, C., Wilson, K.A., Boitani, L., Grantham, H. and Possingham, H.P., 2006: Tradeoffs of different types of species occurrence data for use in systematic conservation planning. *Ecology Letters*, **9**(10): 1136-1145.
- Rosenzweig, M.L., 2010: *Species Diversity in Space and Time*. Cambridge, Cambridge University Press.
- Roura Pascual, N., Krug, R.M., Richardson, D.M. and Hui, C., 2010: Spatially-explicit sensitivity analysis for conservation management: exploring the influence of decisions in invasive alien plant management. *Diversity and Distributions*, **16**(3): 426-438.
- Royle, J.A. and Dorazio, R.M., 2008: *Hierarchical modeling and inference in ecology: the analysis of data from populations, metapopulations and communities*. Academic Press.
- Rykiel, E.J., 1996: Testing ecological models: the meaning of validation. *Ecological Modelling*, **90**: 229-244.
- Sarmiento, J.L. and Gruber, N., 2006: *Ocean Biogeochemical Dynamics*. Princeton, Princeton University Press.
- Scheffer, M., Hosper, S.H., Meijer, M.L., Moss, B. and Jeppesen, E., 1993: Alternative equilibria in shallow lakes. *Trends in Ecology & Evolution*, **8**(8): 275-279.
- Schurr, F.M., Pagel, J., Cabral, J.S., Groeneveld, J., Bykova, O., O'Hara, R.B., Hartig, F., Kissling, W.D., Linder, H.P., Midgley, G.F., Schröder, B., Singer, A. and Zimmermann, N.E., 2012: How to understand species' niches and range dynamics: a demographic research agenda for biogeography. *Journal of Biogeography*, **39**(12): 2146-2162.

- Shaw, R.G. and Etterson, J.R., 2012: Rapid climate change and the rate of adaptation: insight from experimental quantitative genetics. *New Phytologist*, **195**(4): 752-765.
- Shin, Y.-J. and Cury, P.M., 2001: Exploring fish community dynamics through size-dependent trophic interactions using a spatialized individual-based model. *Aquatic Living Resources*, **14**(02): 65-80.
- Shugart, H.H., 1984: *A theory of forest dynamics: The Ecological Implication of Forest Succession Models*. New York, Springer Verlag.
- Shukla, J., Nobre, C. and Sellers, P., 1990: Amazon deforestation and climate change. *Science*, **247**(4948): 1322-1325.
- Simberloff, D., 1976: Species turnover and equilibrium island biogeography. *Science*, **194**(4265): 572-578.
- Sinclair, A.R.E. and Gosline, J.M., 1997: Solar Activity and Mammal Cycles in the Northern Hemisphere. *American Naturalist*, **149**(4): 776.
- Sitch, S., Smith, B., Prentice, I.C., Arneeth, A., Bondeau, A., Cramer, W., Kaplan, J.O., Levis, S., Lucht, W., Sykes, M.T., Thonicke, K. and Venevsky, S., 2003: Evaluation of ecosystem dynamics, plant geography and terrestrial carbon cycling in the LPJ dynamic global vegetation model. *Global Change Biology*, **9**(2): 161-185.
- Slobodkin, L.B., 1961: *Growth and Regulation of Animal Populations*. New York, Holt, Rinehart and Winston.
- Smith, B., Prentice, I.C. and Sykes, M.T., 2001: Representation of vegetation dynamics in the modelling of terrestrial ecosystems: comparing two contrasting approaches within European climate space. *Global Ecology and Biogeography*, **10**(6): 621-637.
- Smith, J. and Smith, P., 2007: *Introduction to environmental modelling*. Oxford, Oxford University Press.
- Sousa, T., Domingos, T. and Kooijman, S.A.L.M., 2008: From empirical patterns to theory: a formal metabolic theory of life. *Philosophical Transactions of the Royal Society of London. B, Biological Sciences*, **363**(1502): 2453-2464.
- Stock, C.A., Alexander, M.A., Bond, N.A., Brander, K.M., Cheung, W.W.L., Curchitser, E.N., Delworth, T.L., Dunne, J.P., Griffies, S.M., Haltuch, M.A., Hare, J.A., Hollowed, A.B., Lehodey, P., Levin, S.A., Link, J.S., Rose, K.A., Rykaczewski, R.R., Sarmiento, J.L., Stouffer, R.J., Schwing, F.B., Vecchi, G.A. and Werner, F.E., 2011: On the use of IPCC-class models to assess the impact of climate on Living Marine Resources. *Progress in Oceanography*, **88**(1-4): 1-27.
- Stockwell, D. and Peters, D., 1999: The GARP modelling system: problems and solutions to automated spatial prediction. *International journal of geographical information science*, **13**(2): 143-158.
- Suding, K.N., Lavorel, S. and Chapin, F.S., 2008: Scaling environmental change through the community-level: a trait-based response-and-effect framework for plants. *Global Change Biology*, **14**: 1125-1140.
- Sutherland, W.J., 2006: Predicting the ecological consequences of environmental change: a review of the methods. *Journal of Applied Ecology*, **43**(4): 599-616.
- Tengö, M., Malmer, P., Brondizio, E., Elmqvist, T. and Spierenburg, M., 2013: The Multiple Evidence Base as a framework for connecting diverse knowledge systems in the IPBES. Discussion Paper. Stockholm Resilience Centre (SRC), Stockholm University, Stockholm.
- Thaman, R., Lyver, P., Mpande, R., Perez, E., Cariño, J. and Takeuchi, K., 2013: The contribution of indigenous and local knowledge systems to IPBES: Building Synergies with Science. IPBES Expert Meeting Report. UNESCO/UNU, Paris.
- Thuiller, W., Münkemüller, T., Lavergne, S., Mouillot, D., Mouquet, N., Schiffrers, K. and Gravel, D., 2013: A road map for integrating eco-evolutionary processes into biodiversity models. *Ecology Letters*, **16**: 94-105.
- Tilman, D., Fargione, J., Wolff, B., D'Antonio, C., Dobson, A., Howarth, R., Schindler, D., Schlesinger, W.H., Simberloff, D. and Swackhamer, D., 2001: Forecasting agriculturally driven global environmental change. *Science*, **292**(5515): 281-284.
- Tittensor, D.P., Micheli, F., Nyström, M. and Worm, B., 2007: Human impacts on the species–area relationship in reef fish assemblages. *Ecology Letters*, **10**(9): 760-772.
- Triantis, K.A., Guilhaumon, F. and Whittaker, R.J., 2012: The island species-area relationship: biology and statistics. *Journal of Biogeography*, **39**(2): 215-231.
- Uecker, H., Otto, S.P. and Hermisson, J., 2014: Evolutionary Rescue in Structured Populations. *The American Naturalist*, **183**(1): E17-E35.

- van Vuuren, D.P., Sala, O.E. and Pereira, H.M., 2006: The future of vascular plant diversity under four global scenarios. *Ecology and Society*, **11**(2): 25.
- van Vuuren, D.P., Feddema, J., Frohling, S., Hibbard, K., Hurtt, G., Lamarque, J.F., Chini, L.P., Riahi, K., Rose, S., Smith, S. and Stehfest, E., 2009: Running policy-relevant Integrated Assessment Models scenarios in Earth System Models. *IOP Conference Series: Earth and Environmental Science*, **6**(44): 442008.
- Vandermeer, J.H. and Goldberg, D.E., 2004: *Population Ecology: First Principles*. Princeton, NJ, Princeton University Press.
- Verhoef, H.A. and Olf, H., 2010: Trophic dynamics of communities. In *Community ecology: processes, models, and applications*, 25-36.
- Walters, C., Christensen, V., Walters, W. and Rose, K., 2010: Representation of multi-stanza life histories in Ecospace models for spatial organization of ecosystem trophic interaction patterns. *Bulletin of Marine Science*, **86**: 439-459.
- Walters, C.J., Christensen, V., Martell, S.J. and Kitchell, J.F., 2005: Possible ecosystem impacts of applying MSY policies from single-species assessment. *ICES Journal of Marine Science*, **62**(3): 558-568.
- Warren, R., 2011: The role of interactions in a world implementing adaptation and mitigation solutions to climate change. *Philosophical Transactions of the Royal Society a-Mathematical Physical and Engineering Sciences*, **369**(1934): 217-241.
- Weitzman, M.L., 2009: On Modeling and Interpreting the Economics of Catastrophic Climate Change. *Review of Economics and Statistics*, **91**(1): 1-19.
- Whiteman, G., Hope, C. and Wadhams, P., 2013: Climate science: Vast costs of Arctic change. *Nature*, **499**(7459): 401-403.
- Wikle, C.K., 2003: Hierarchical Bayesian models for predicting the spread of ecological processes. *Ecology*, **84**(6): 1382-1394.
- Willis, S.G., Thomas, C.D., Hill, J.K., Collingham, Y.C., Telfer, M.G., Fox, R. and Huntley, B., 2009: Dynamic distribution modelling: predicting the present from the past. *Ecography*, **32**(1): 5-12.
- Wilson, R.J., Davies, Z.G. and Thomas, C.D., 2009: Modelling the effect of habitat fragmentation on range expansion in a butterfly. *Proceedings of the Royal Society of London B: Biological Sciences*, **276**(1661): 1421-1427.
- Woodward, F.I. and Cramer, W., 1996: Plant functional types and climatic changes: Introduction. *Journal of Vegetation Science*, **7**(3): 306-308.
- Woodward, G. and Hildrew, A.G., 2001: Invasion of a stream food web by a new top predator. *Journal of Animal Ecology*, **70**(2): 273-288.
- Woodward, G., Ebenman, B., Emmerson, M., Montoya, J., Olesen, J., Valido, A. and Warren, P., 2005: Body size in ecological networks. *Trends in Ecology & Evolution*, **20**(7): 402-409.
- WWF, 2013: Working with Indigenous and Local Knowledge Systems for the conservation and sustainable use of biodiversity and ecosystem services. World Wildlife Fund, WWF.

Chapter 5 Modelling consequences of change in biodiversity and ecosystems for nature's benefits to people

Coordinating Lead Authors:

Garry Peterson (Sweden), Jane Kabubo-Mariara (Kenya)

Lead Authors:

Neville Crossman (Australia), Brenda Rashleigh (USA), Pablo Munoz (Chile), Jonathan Anticamara (Philippines), Makarius Victor Mdemu (Tanzania), Ainars Aunins (Latvia)

Contributing Authors:

William Cheung (China), Adrian Vogl (USA)

Review Editors:

David Vačkář (Czech Republic), Anders Skonhoft (Norway)

Purpose of this chapter: Describes the current state of ecosystem system service models and modelling approaches for IPBES assessments and other users of ecosystem service models. Highlights the strengths and weaknesses of different approaches to modelling ecosystem services and critically reviews major types of ecosystem-service models for generating outputs of relevance to different policy and decision-making contexts (as covered in Chapter 2).

Target audience: Aimed mostly at a more technical audience – i.e., scientists and practitioners wanting to identify appropriate approaches to modelling ecosystem services for particular applications.

Key Findings

The main contribution of an ecosystem service approach to decision making comes from considering bundles and trade-offs among multiple ecosystem services (5.2, 5.5). Assessments of an ecosystem service in isolation can be useful for specific contexts, but assessing ecosystem services individually risks hiding trade-offs and synergies between ecosystem services that are often crucial in many decision-making contexts.

Models of ecosystem service are undergoing rapid development (5.4). The number, diversity and application of ecosystem service models has greatly increased over the past decade. A variety of ecosystem service models exist, however most models have limited ability to represent dynamic processes or social-ecological feedbacks, consequently the ability of ecosystem service models to project or analyse alternatives is weak, and most current models do not adequately represent the Intergovernmental Platform on Biodiversity and Ecosystem Services (IPBES) conceptual framework. There is a lack of models that bridge multiple knowledge systems or connect to indigenous or local knowledge. Many new types of ecosystem service models are in development, and research aims to address many of the limitations of ecosystem service models over the next decade.

Modelling the impact of ecological changes on human well-being is still in preliminary stages, as is modelling impact of changes in institutions and anthropogenic assets on ecosystem services (5.2, 5.5, 5.7). Developing such tools will require investment and trans-disciplinary collaboration of policy makers, with natural and social scientists to develop new frameworks, methods, and tools. The development of models that integrate different ways of assessing human well-being is particularly needed as there are a diversity of ways in which human well-being can be assessed, and the study of human well-being is also rapidly developing.

Modelling methods, tools, and participatory processes each have particular strengths and weaknesses that make them appropriate to different decision contexts (5.4, 5.5). Ecosystem service models can be useful as part of a process of developing, choosing, implementing and evaluating alternative ecosystem service strategies. This chapter provides guidance on how to match tools and decision contexts. Complex models are useful for integration and large-scale analysis, but in many contexts relatively simple models can be more useful than complex models, because they are easier to understand, use, and assess. Simplicity is especially important in assessing multiple ecosystem services where the reliable models of multiple services have not been well developed.

Applying multiple models to the same case produces more robust decisions because different types of analyses and models are needed at different stages of the policy cycle (5.5). Most real world applications of ecosystem service models combine multiple modelling approaches and tools because no one modelling approach or tool is able to do everything well. Different phases in the policy cycle have different types of decisions contexts and require different types of modelling tools. Furthermore, even within a phase of the policy cycle, multiple models are needed to analyse how changes in biological diversity, anthropogenic assets alter the benefits different people receive from nature.

Models of biodiversity and models of ecosystem services are not well connected. Ecologists increasingly understand how biodiversity produces ecological functions (Chapter 4), however many ecosystem services models utilise aspects of land use and land cover to predict ecosystem services (5.4, 5.5.3, Chapter 4). Including biodiversity in ecosystem service models is challenging due to a lack of spatially explicit biodiversity data. Land use and land cover are related to biodiversity, but spatial configuration, history and management also shape local and regional biodiversity. Making progress on the connections between biodiversity and ecosystem service models would improve models, as would improving the understanding of the role of social and abiotic factors in mediating ecosystem services. Ecosystem services are produced by social and ecological factors in addition to biodiversity, so including all these aspects would likely increase the predictive quality of ecosystem service models. Which approaches yield the biggest improvements in model quality will likely depend upon social-ecological context, data availability and the ecosystem services being considered.

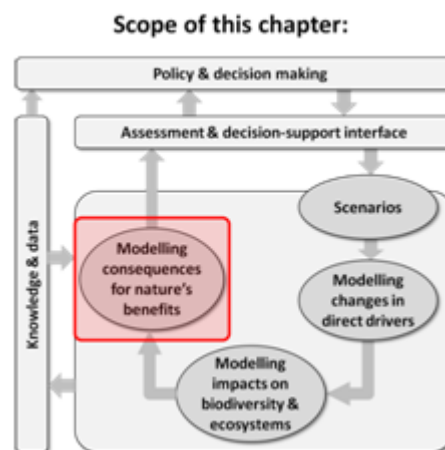

Key recommendations

IPBES can help foster the development of a community of practice for ecosystem service modelling, data and scenario building and use (5.6, Chapter 7). Currently ecosystem service research is fragmented and models and scenarios would benefit from more integration. Some modelling groups have developed a community of practice, but wider communities of practice need to be developed to support the use of models and scenarios in multiple regional assessments and develop new models, scenarios and methods to better bridge multiple knowledge systems. IPBES could use its Knowledge, Information and Data task force (Deliverable 1d) to facilitate access to scenarios, models and data by encouraging governments and scientists to make their models and data freely available using open access or creative commons licensing. Already available is the Ecosystem Services Partnership (ESP) spatial data mapping and sharing tool jointly developed by the European Commission Joint Research Centre and the CSIRO (Commonwealth Scientific and Industrial Research Organisation) (see <http://esp-mapping.net/Home/>). This ESP tool allows users to upload and download spatial data on mapped ecosystem services, and query the database on what data is available for different ecosystem services and locations. IPBES could also use its Capacity Building task force (Deliverables 1a/b) to promote, maintain, and enhance communities of practice.

IPBES can play an important role in promoting new ways to include multiple values and indigenous and local knowledge systems in models and scenarios (5.2, 5.5, 5.7). Alternative values, multiple knowledge systems, and indigenous and local knowledge are rarely addressed in current modelling work, yet have been highlighted as a priority area for IPBES. If these issues are to be explored in regional and global assessments there will have to be investment in including multiple values and knowledge systems in models and scenarios. It is important that IPBES ensures that the task forces on Capacity Building (Deliverables 1a/b), Indigenous and Local Knowledge (Deliverable 1c) and Knowledge, Information and Data (Deliverable 1d) and the expert group on Values (Deliverable 3d) facilitate communication among these communities as well as the development of new model and scenario approaches.

Thematic, global and regional assessments of ecosystem services (IPBES Deliverables 2b, 2c, 3b) would benefit from the analysis of outputs from models of ecosystem services at multiple scales (5.3.1, 5.5). In particular, global and regional models that evaluate multiple ecosystem services are recent developments. They have not yet been sufficiently tested and often do not correspond to ecosystem services observed in many places. Local scale models of multiple ecosystem services have been much more widely tested and applied, but methods for scaling up to regions and or the globe pose many challenges. Global and regional assessments should consider linking and analysing connections among multiple cross-scale ecosystem service assessments that include models of local ecosystem service dynamics.

Regional assessments of ecosystem services (IPBES Deliverable 2b) could link and analyse connections among multiple cross-scale ecosystem services based on models of local ecosystem service dynamics (5.4.3). Local models of ecosystem services are better developed than regional or large scale models of ecosystem services. Therefore, regional assessments should strongly consider integrating and comparing multiple local models of ecosystem services as opposed to relying primarily on regional scale models of ecosystem services.

5.1 Introduction

Research on modelling the benefits that nature supplies to people, or ecosystem services, has rapidly expanded and diversified over the past decade. This chapter assesses the current state of these models from the perspective of IPBES, and identifies the substantial gaps within this research. The first part of this chapter provides critical reviews of the key conceptual components in modelling connections between ecosystem services and human well-being, as well as how these connections are shaped by changes in biodiversity, anthropogenic assets, institutions, and other drivers (Figure 5.1). The second part of the chapter then reviews the main modelling approaches for assessing ecosystem services, and relates these approaches to the different decision contexts in which these models can be used. The chapter concludes with an assessment of gaps, recommendations for actions, and future research that would develop the capacity to better use of ecosystem services and human well-being models in IPBES.

5.2 Conceptual framework and knowledge for modelling ecosystem services and human well-being linkages

This chapter focuses on how people have used models and scenarios to understand how ecosystems contribute to human well-being. The contribution of ecosystems to human well-being is strongly shaped by social institutions and anthropogenic assets. Most of Earth's ecosystems have been reshaped, restructured, and reorganized by people. This shaping has occurred through intentional ecological engineering (such as terraced rice paddy agriculture, to enhance the availability of desired benefits), as well as unintentionally from unintended by-products of other actions (such as the impact of climate change on ecosystems). Social activities or conditions as well as biophysical dynamics directly impact ecosystems and human well-being (Butler and Oluoch-Kosura, 2006; Fremier et al., 2013). The IPBES conceptual framework integrates these pathways of interaction among people and nature (Figure 5.1). This chapter builds on chapters 2 to 6 in this assessment that address related parts of the IPBES conceptual framework. Chapter 2 focuses on the decision contexts in which models of biodiversity and ecosystem services are used, Chapter 3 on

drivers of changes in nature, Chapter 4 on modelling impacts of these drivers on biodiversity and ecosystems, and Chapter 6 on how to integrate multiple models. The following section explains how models and scenarios of nature's benefits to people relate to the IPBES conceptual framework.

5.2.1 Ecosystem services, human well-being and the IPBES framework

To develop and implement policies and practices that ensure and enhance the flow of ecosystem services to people requires including ecosystem services in decision-making. There are a wide variety of contexts in which decision are made concerning ecosystem services, and effectively including ecosystem services in these decisions requires different types of models and scenarios that can identify how social and ecological change alter the dynamics of ecosystem services and human well-being. In the context of IPBES, models and scenarios are essential components of IPBES regional and thematic assessments, and can enable dialogue and communication among the broader IPBES community. Furthermore, the IPBES conceptual framework recognizes that different knowledge systems will conceive of nature's benefits in different ways that go beyond the use of different ecosystem services, but include different conceptualisations of access, decision-making, knowledge generation, and knowledge itself (Díaz et al., 2015; Houde, 2007). This plurality is a challenge to modelling approaches that utilize a fixed model, but can be well incorporated by modelling and scenario approaches that enable dialogue among different people through participatory processes (Davies et al., 2015).

Nature provides multiple benefits to human societies. Throughout this chapter these benefits are referred to as ecosystem services (MA, 2005a). These benefits are not produced in isolation from one another, because the ecological and social processes that produce ecosystem services interact with one another so that actions to increase the supply of one ecosystem service often impact other ecosystem services (Bennett et al., 2009).

Furthermore, ecosystem services are produced at different scales, which means that no single scale is well suited to manage all ecosystem services, making it difficult to avoid conflicts and interactions between ecosystem service providers and beneficiaries. The benefits from ecosystem services are diverse and unevenly studied and conceptualised. Best understood are the flows of food and materials people receive from nature. Much more poorly understood are the ways nature stabilizes and regulates environmental variation; how nature contributes to people's cultural, psychological and spiritual well-being; as well as how biodiversity provides options and opportunities for people in the future.

Demand for ecosystem services is increasing even as intensified human modification of Earth's ecosystems is reducing the capacity of these ecosystems to continuously provide these benefits (Cardinale et al., 2012). Paradoxically, despite the simplification, conversion, and degradation of many ecosystems, the past century has seen consistent and global increases in health, life-expectancy, education, and income (UNDP, 2014). Much of the global simplification of ecosystems has been to replace diverse ecosystems with those producing high levels of agricultural ecosystem services, and to date this conversion has been viewed to enhance rather than decrease human well-being (Raudsepp-Hearne et al., 2010b). In addition, even simplified ecosystems can provide diverse ecosystem services, for example research has shown that while the conversion of diverse tropical forest into monoculture oil palm plantations eradicated a multitude of biodiversity and reduced ecosystem services, it did not eliminate many preferred services and it enhanced others (Abram et al., 2014). Furthermore, during the past century social innovation and technical advancement have increased the productivity of ecosystem services, allowing more benefits to be obtained with less impact.

Scientists have identified many aspects of how ecosystem services contribute to human well-being, but how biodiversity, anthropogenic assets, institutions, and culture shape these links is only beginning to be understood.

Nature's benefits to people are strongly shaped by the dynamic interaction of anthropogenic assets, biodiversity and ecosystems, and institutions (Figure 5.1). Nature's benefits are typically unequally distributed among different sectors of the society or beneficiaries. The relationships between people and ecosystem services have been conceptualised in a variety of ways prior to the IPBES conceptual framework (Figure 5.2). Different conceptual frameworks have highlighted either a linear flow of nature's benefits to people, or a cyclical interaction between people and nature. While the IPBES conceptual framework is cyclical, often the practice of ecosystem service assessment and modelling has been linear. Circular conceptualisations better capture the reality of interactive feedbacks between people and nature, but linear conceptualisations are much easier to analyse and operationalize.

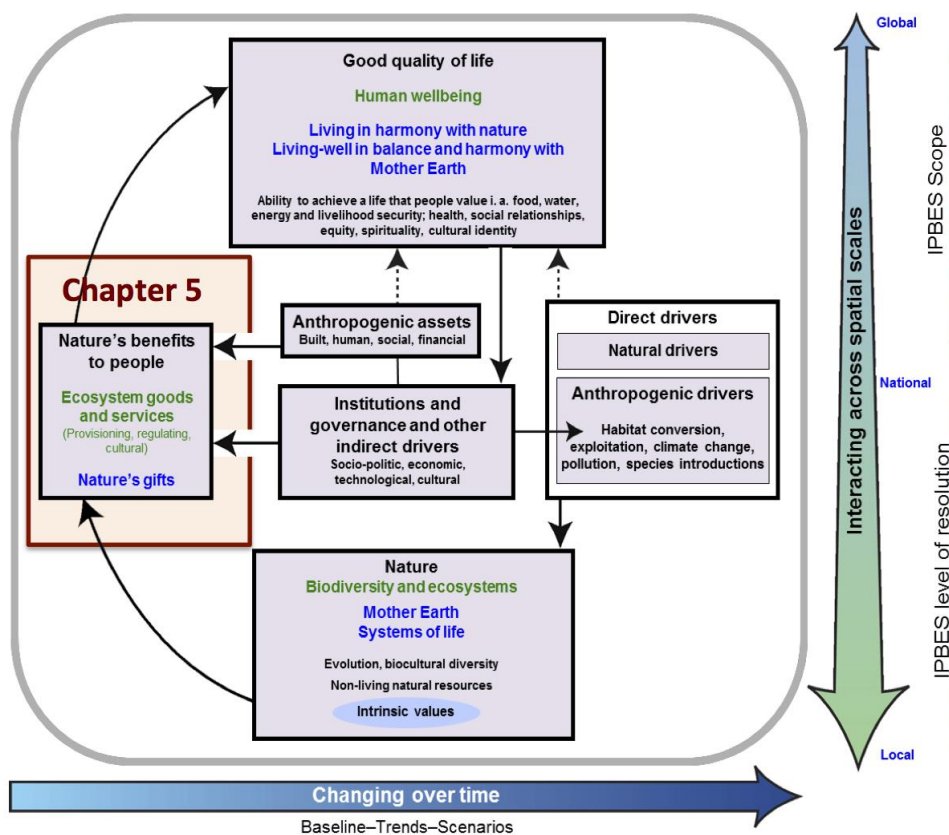

Figure 5.1: This chapter focuses on approaches to modelling how nature provides benefits to people, and how these benefits are influenced by nature, institutions, anthropogenic assets, and natural and anthropogenic direct drivers.

Ecosystem service modelling approaches need to be able to represent the key features of these conceptual frameworks in ways that are useful across a variety of decision contexts. The IPBES framework and others emphasise the importance of the following three considerations in ecosystem services and human well-being modelling: (1) scales (e.g., local, national, regional, global, and scale transferability), (2) interactions (e.g., how institutions shape access to ecosystem services), and (3) feedbacks (e.g., mutual reinforcing interactions between ecosystem services and human well-being). Additionally, landscape spatial pattern and temporal dynamics usually need to be considered to model ecosystem services in any real world processes. While models need to be able to represent the temporal and spatial complexity of ecosystem services, it is also important they can be used as tools for learning and bridging between different knowledge systems. These goals of learning and bridging are both important to IPBES and are essential to the practical use of ecosystem service models in decision contexts involving diverse stakeholders or contested issues.

However, no existing ecosystem services and human well-being modelling tools or approaches capture all these dynamics (scales, interactions and feedbacks), and combining different models and tools to better incorporate these dynamics remains an area that requires further research and development (Carpenter et al., 2009).

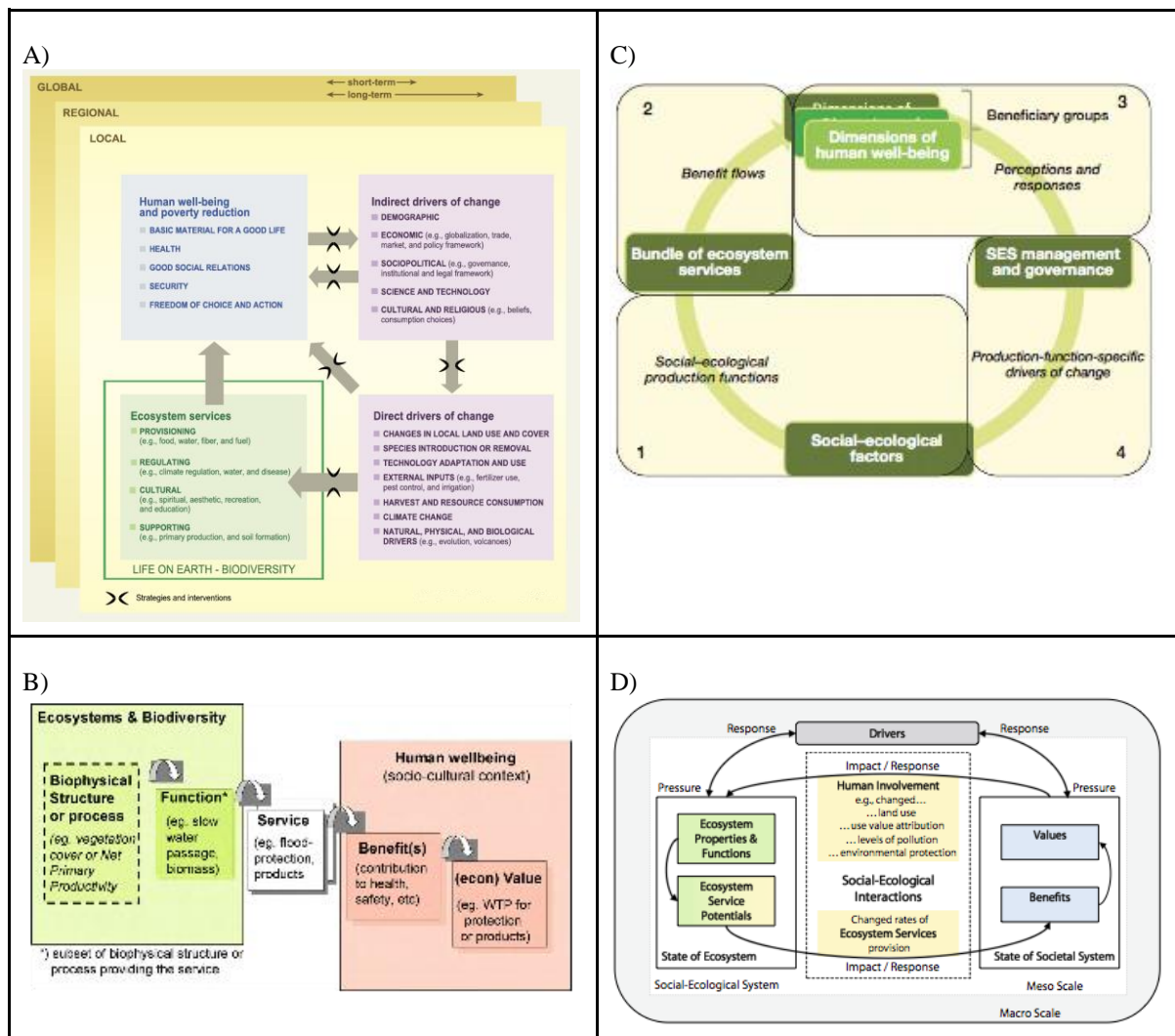

Figure 5.2: There are many ways that natural and anthropogenic assets have been conceptualised as producing ecosystem services. Many of these conceptualisations have a flow of benefits from nature to society, while others emphasize the co-creation of benefits by nature and society. (A) The Millennium Ecosystem Assessment conceptual framework (MA, 2005a); (B) The cascade model of ecosystem services (Haines-Young, 2011); (C) An SES approach to identifying social-ecological factors and interactions highlights the importance of dynamic feedbacks between society and ecosystems (Reyers et al., 2013); and (D) An integration of the ecosystem service cascade (B) and social-ecological perspective (C) (Nassl and Löffler, 2015).

5.3 The type of assessment of ecosystem services varies with decision context

Scenarios and models can improve decision making by transparently representing assumptions underpinning decisions, compressing and synthesising complex information in an understandable way, identifying unexpected outcomes, and exploring alternative policies.

The value and utility of a model has to be judged against the context in which it is being used. We describe these situations as decision contexts (Chapter 2).

The attributes of the decision context will determine the scope of ecosystem service modelling and scenario analysis required. For example, the approaches useful to resolve disputed forest governance, decision making processes, management, and logging between an indigenous people and a national government, will be different from approaches that are useful for helping a city plan highway development in an urban wetland, or government marine planners attempting to craft policies that benefit conservation as well as sport and commercial fisheries.

A decision context can be defined by numerous variables describing biophysical, social, economic, spatial and temporal dimensions (Chapter 2, Table 5.1). Important attributes of decisions contexts relevant to ecosystem service modelling include the following: temporal and spatial extent and resolution, ecological complexity, political (jurisdictions and administrative) scale, socio-cultural characteristics of stakeholders (knowledge systems, value pluralities), governance and institutional settings, and the decision objectives and scope. A decision context determines what types of modelling approaches are appropriate for a given situation. For example, modelling

approaches that are transparent and enable participation, exploration, interaction and negotiation may be more applicable when there is disagreement and divided governance. The best types of models in these situations will be the simpler expert opinion and correlative models which are typically participatory. Alternatively, more technical and data intensive approaches such as process-based and integrative models may be more appropriate for decision contexts which have clear objectives, sound system understanding and non-contested governance (Table 5.1).

Table 5.1: Decision contexts (from Chapter 2) and how they relate to modelling strategies. For each aspect of a decision contexts different types of modelling approach are needed for easier to decide or more difficult to decide modelling contexts. The modelling strategies columns show focuses or approaches recommended for easier or more difficult decisions relevant for each row.

	Decision context attributes	Easier to decide	More difficult to decide	Modelling strategies for easier decisions	Modelling strategies for more difficult decisions
Governance	<i>actors</i>	single/executive	multiple/negotiated	optimization	multi-criteria
	<i>history</i>	history of governance	novel governance	predictive	explorative
	<i>legitimacy</i>	accepted	contested	implementation	conflict resolution
	<i>sectors</i>	single	multiple	single model	integrated models
	<i>participation</i>	consultation	decision	visualization	group interaction
Decision	<i>decision time horizon</i>	short term (months)	longer term (decades)	extrapolate	feedbacks
	<i>decision frequency</i>	one-off	repeated	adaptive	robust
	<i>objectives</i>	single	multiple	securing benefits	managing trade-offs
Stakeholders	<i>values</i>	homogenous	diverse	assumed	negotiated
	<i>knowledge system</i>	homogenous	diverse	single	multiple models
Ecology	<i>heterogeneity</i>	single ecosystem	multiple ecosystems	single model	multiple models
	<i>diversity</i>	single species	multi species	populations	food webs
	<i>flows across landscape</i>	weak connections	strong connections	independent	feedbacks
	<i>stochasticity</i>	low and predictable	high and unpredictable	deterministic	stochastic
Scale	<i>cross-scale dynamics</i>	weak external influence	strong external influence	focus system	driver/system
	<i>temporal extent</i>	short-term	long-term	correlative	processes
	<i>temporal grain</i>	seconds	millennia	data	drivers
	<i>spatial extent</i>	local	global	data availability	data accuracy
	<i>spatial grain</i>	metres/seconds	kilometres/degrees	detailed data	aggregated data
Information	<i>scientific knowledge</i>	high	low	predictive models	exploratory models
	<i>data availability</i>	high	low	precise models	general models
	<i>scientific capacity</i>	high	low	new models	model adapted

The policy cycle (Chapter 2) can be used to define four stylized types of decision making context: agenda-setting, policy design, implementation, and review (see Chapter 2). Agenda setting involves identifying and defining the features of a problem. Policy design involves the formulation of rules and regulations to guide actions to address that problem. Policy implementation is a process of organising, prioritising, and scheduling activities in order to achieve articulated goals. Review involves navigating the inevitable tensions, trade-offs, and opportunities that emerge from implementing plans and policies. Scenarios and models can improve decision making by (1) transparently representing key processes and assumptions that underpin decisions; (2) compressing and synthesising complex information in an understandable way; (3) helping identify unexpected outcomes, and (4) testing and exploring new policies and assumptions.

Decision contexts are also shaped by social, ecological and biophysical factors. Social factors include why a decision is being made, who is making the decision, and whether that decision maker or decision making body is considered to be legitimate by other people impacted by the decision. The ecological factors include what aspects of nature are considered in a decision (e.g., water, a population of a species, or an interacting ecosystem), what ecosystem services are considered, and how ecological variables are being considered in the landscape or seascape.

Many decisions involving biodiversity, ecosystem services, and human well-being are complex and morally fraught. Decisions may rely on poorly understood ecological processes, and involve conflicts of interests and values among different groups in society who may have different worldviews, wealth, and power. Structured decision making can help improve such processes, but there is likely to be disagreement about what decision process is legitimate as well as what decisions should be made (see Chapter 2). For example, in the management of a coastal fishery, commercial fishers, indigenous groups, environmental groups and government bodies are likely to disagree over who makes decisions, how they are made, and the boundaries of decision making (Peterson, 2000).

In this chapter we relate different approaches to modelling ecosystem services to different phases in the policy cycle and different types of decision contexts. We also specifically address the needs of ongoing IPBES regional and sub-regional assessments. Below, we briefly outline the major aspects and aims of IPBES regional and sub-regional assessments as well as the likely decisions contexts for the major aspects of assessments.

5.3.1 IPBES regional and subregional assessments

The IPBES regional and subregional assessments (IPBES/3/6, <http://ipbes.net>) are assessing five major aspects of biodiversity and ecosystem services as follows:

1. Trajectories of nature's values: possible changes in the values of nature's benefits to people, including interrelationships between biodiversity, ecosystem functions and benefits to society, as well as the status, trends, and future dynamics of ecosystem goods and services.
2. Trajectories of ecosystems: the status and trends of biodiversity and ecosystem services including the structural and functional diversity of ecosystems and genetic diversity.
3. Trajectories of drivers: the status and trends of indirect and direct drivers and the interrelations of such drivers.
4. Risks: future risks to drivers, biodiversity and ecosystems, ecosystem services, and human-well-being under plausible socio-economic futures.
5. Policy responses: the effectiveness of existing responses and alternative policy and management interventions, including the Strategic Plan for Biodiversity 2011-2020 and its Aichi biodiversity targets, and the national biodiversity strategies and action plans developed under the Convention on Biological Diversity (CBD).

The assessments are currently being undertaken for four regions (Africa, Americas, Asia-Pacific, Europe and Central Asia), with each regional assessment following a common structure but tailored to regional-specific contexts. The regional assessments are aiming to answer policy relevant questions such as the following: (1) the contribution of biodiversity and ecosystem services to economies, livelihoods and well-being; (2) the status and trends of that biodiversity and ecosystem services; (3) the pressures driving change in that biodiversity and ecosystem services; and (4) possible interventions to ensure sustainability of the biodiversity and ecosystem services (IPBES/3/6/Add.1, <http://ipbes.net>). The IPBES global assessment will then build on the regional and subregional assessments with processes established to ensure coherence between the two scales of assessment.

5.3.2 IPBES decision contexts

The decision contexts of IPBES are many and varied; however, these assessments will require many different approaches to modelling and scenario analyses. For example, the decision contexts for influencing trajectories of nature's economic values to humans are grounded in the social, geographical, and economic sciences, and will be defined primarily by the importance of ecosystem service flows to beneficiaries. These analyses typically focus on geopolitical boundaries at scales relevant to people and are shaped by available demographic data. Decisions impacting substantially on beneficiaries will likely be made at coarse scale within socio-political contexts. This will require understanding, quantifying, and mapping the flows of services to beneficiaries, an area of research only recently emerging (Bagstad et al., 2014; Reyers et al., 2013; Syrbe and Walz, 2012). Recent concepts for linking beneficiaries to ecosystem services include quantifying service provisioning and benefitting areas, and service connecting regions. For example, Renaud et al. (2013) clearly demonstrate the value of ecosystems to people by showing how ecosystems can reduce risks associated with natural disasters. The questions asked within IPBES may include identifying natural ecosystems of high scenic beauty and recreational value, and the users of these areas (Palomo et al., 2013; Palomo et al., 2014). Also important is the location of communities most vulnerable to climate change, who could be beneficiaries of carbon sequestration as well as climate regulation services, and the location of communities most vulnerable to natural disasters such as flooding, landslides, and cyclones, who could be beneficiaries of flood regulation, erosion control and extreme event moderation ecosystem services. Another emerging area of research is the impact of increasing urbanisation on the demand, supply, and flow of ecosystem services from agro-ecosystems, and the subsequent risks with the increased disconnect between ecosystems and people (Cumming et al., 2014).

While many social, cultural, and political dynamics shape access to ecosystem services and exposure to hazards, much of recent progress in ecosystem science focuses on developing biophysical models that aim to represent the processes that underlay the supply of ecosystem services, and the changes to supply from changes in ecosystems and biodiversity. Decisions will often be location-specific and will involve identifying trade-offs in biodiversity, ecosystem, and ecosystem service supply outcomes between alternative approaches to managing the land, water, and biota. It is important to establish the relationships between elements of biota and physical systems and the supply of ecosystem services to provide evidence that management interventions will lead to beneficial outcomes, and important to identify new methods for incorporating social-ecological feedbacks and how social dynamics shape exposure to hazards and access to ecosystem services.

The questions asked related to the trajectories of ecosystems may include understanding the efficacy of land or water management interventions for improving the condition of ecosystems and the subsequent improvements in the supply of ecosystem services. The scale of these types of decisions will generally be small (e.g., plot, paddock, river reach, and vegetation community), although may extend to landscapes if ecological connectivity is of interest, and will require the collective involvement of a highly diverse group consisting of many decision makers.

Another decision context of assessments aims to understand the drivers and risks to biodiversity, ecosystem services, and human well-being, and the effectiveness of policy responses that mitigate risk. Decisions here will be improved by scenario analyses. A scenario is a plausible and often simplified description of how the future may develop, based on a coherent and internally consistent set of assumptions about key driving forces and their relationships (MA, 2005b). The development of scenarios has often been used to bridge knowledge, information and data derived from multiple knowledge systems.

IPBES could both use existing scenario analyses and develop their own scenarios. There are many different types of scenario analysis that vary in terms of being exploratory or normative, expert-led or participatory, as well as in the scale at which they are conducted. For example Bryan and Crossman 2013, used high resolution spatial data, to simulate nearly 2,000 economic and biophysical scenarios to evaluate the land use changes, and subsequent impacts on the supply of ecosystem services, that may occur to the year 2050 in southern Australia following policy that creates markets for food, water, carbon and biodiversity. Using comparable methods, but for the United Kingdom, Bateman et al. (2013) explore the potential land use changes and subsequent impacts on ecosystem service supply of selected services under six plausible future socio-economic scenarios that drive land use change. There are others who have done similar work for other parts of the world, such as in the USA (Nelson et al., 2009), South Africa (Egoh et al., 2010) and Europe (Willemen et al., 2010, Willemen et al., 2012). Analyses typically forecast the impact on and trade-offs to biodiversity and ecosystem service supply and demand from external influences, such as new policy and/or climate change (Bryan et al., 2014; Nelson et al., 2013). Other scenario analyses have adopted a narrative based approach to include processes that are not modelled or well understood, such as shifts in diet or immigration policy, to be integrated with quantitative models of ecological or climate dynamics (Oteros-Rozas et al., 2015). These approaches have also been used to incorporate indigenous and local knowledge systems into scenarios. Additionally, the archetypes or families of global scenarios identified in Table 6.3 could be used to structure or focus IPBES's global assessments.

Overall, IPBES can use scenarios to bridge knowledge systems, integrate disparate models and data, evaluate policy, and focus scientific investigation and synthesis.

5.4 Types of models

There are a variety of approaches and tools that have been used to assess and model ecosystem services. This section review different approaches and tools for modelling ecosystem services. It starts by describing correlative (5.4.2), process-based (5.4.3), and expert-based (5.4.4) approaches to modelling ecosystem services, and then compares these general approaches (5.4.5). We include the creation of scenarios as part of expert-based modelling. More generally used ecosystem service modelling tools, such as the Integrated Model to Assess the Global Environment (IMAGE), Integrated Valuation of Ecosystem Services and Trade-offs (InVEST) and Ecopath with Ecosim (EwE) are discussed and compared (5.4.6), and the section concludes with a brief discussion of economic approaches to ecosystem services (5.4.7). The following section (5.5) assesses how well these different approaches match different decision contexts.

5.4.1 What types of attributes differentiate ecosystem services models

Modelling the impacts on beneficiaries resulting from change in biodiversity and ecosystems takes many different forms for many different purposes (Crossman et al., 2013b).

Models can be classified as correlative, process-based, and expert-based (Chapter 4).

Each of these different modelling approaches have strengths and weaknesses that make them a better fit to different types of decision contexts (Cuddington et al., 2013). In real world problems, different types of models are often used in combination or integrated together (Chapter 6).

While ecosystem services models are available in all of these categories, most general models of ecosystem services tend to be either correlative models of ecosystem services that use land cover and land use to predict ecosystem services, or process-based models that simulate biophysical processes and typically arrive at production functions and detailed system understanding (Crossman et al., 2013a; Kareiva et al., 2011; Maes et al., 2016). Many local or regional ecosystem service assessments have used expert-based models (Davies et al., 2015), while ecosystem services have been included in the global integrated assessment model IMAGE (Stehfest et al., 2014), which combines expert, correlative, and process-based models. Most models of ecosystem services do not explicitly model changes in biodiversity (Chapter 4), but use correlative or expert-based approaches to estimate how changes in ecosystem services correspond to changes in land cover and use that implicitly cause and result from changes in biodiversity.

Different models focus on different parts of the IPBES conceptual framework. Most often modelled is the supply side of ecosystem services, i.e., the dynamics of the flow of services from nature to people. Much less common is modelling changes in beneficiaries' demands for ecosystem services: for example how changes in human populations' income or preferences translate to changes in demand for the flow of services (for discussion of drivers of biodiversity and ecosystem change see Chapter 3). While biophysical processes and some economic processes can be modelled by process models, changes in anthropogenic assets and institutions are typically modelled using correlative or rule-based models.

The following section summarises the potential benefits of the correlative, process-based and expert-based ecosystem service modelling approaches (Table 5.2) and briefly describes the attributes, dynamics, scales, levels of complexity, and handling of uncertainty typically found in these models.

Table 5.2

Potential benefits of alternative modelling approaches. The benefits range from low (*) to high (***).

<i>Potential benefit</i>	<i>Correlative</i>	<i>Process-based</i>	<i>Expert-based</i>
Model availability	***	***	***
Evaluate alternative management strategies	*	***	*
Transparent assumptions	***	***	*
Integrates and distributes uncertainty	***	***	*
Appropriate for projection	*	**	*
Allows rapid response	**	*	***
Lower data requirements	*	*	***
Ease of development	**	**	***
Can incorporate social and cultural factors	*	**	***
Ease of bridging knowledge systems	*	*	**

Adapted from Cuddington et al. (2013).

5.4.2 Correlative models

At the simplest level, these models are approximations of ecosystem service flows at a single point in time. Biodiversity (e.g., species distributions), land use, land cover and/or discrete elements of natural capital are usually used as proxies for ecosystem services. For example, spatial data on perennial vegetation extent has been used to estimate the flow of ecosystem services such as moderation of extreme events (in combination with soil information, e.g., Chan et al. (2006), Schulp et al. (2012) and carbon sequestration for climate regulation (in combination with carbon stocks, e.g., Nelson et al., 2009). Soil and/or broader land cover data has also been used as correlative models for other regulating services such as erosion prevention (Maes et al., 2012b).

Ecological production functions have been suggested as a robust way to forecast the effect of human impacts on ecosystems and the supply of ecosystem services (Olander and Maltby, 2014; Wong et al., 2014). According to Wong et al., 2014, ecological production functions can be specified as regression models that measure the statistical influence of marginal changes in ecosystem characteristics on final ecosystem services at a given location and time. A marginal change is the amount of change produced in an output from an additional unit of input, all else held constant. However, such production functions will often fail when change is non-marginal, or when they are used in contexts in which key social-ecological factors are different from those in which they have been parameterised.

Simpler correlative models have improved with the addition of complexity by disaggregating land use/cover data and combining with additional information (e.g., expert knowledge and higher spatial or temporal resolution data). Although still correlative-based, these types of models better account for spatial heterogeneity and may more accurately represent ecological structures and processes. A notable study where land cover data is complemented by a number of additional datasets is the study by Schulp et al. (2014a) who modelled the production and consumption of wild foods in Europe. As a proxy for production, Schulp et al. (2014a) used species distribution models to downscale coarse resolution species distribution data of important wild food species to high resolution land cover data. To model consumption, Schulp et al. (2014a) used a mix of internet and literature searches, ingredient lists from cookbooks, and hunting statistics. A related approach seeks to identify types of social-ecological systems producing different types of bundles of ecosystem services (Raudsepp-Hearne et al., 2010a). This approach uses covariance among multiple ecosystem services across a landscape to identify characteristic patterns of ecosystem service production.

5.4.2.1 Strengths and weaknesses

The strength of correlative models' is that they are simple and easy to apply, but the weakness is that because they are not based on process understanding they can dramatically fail in novel or data poor situations.

The relative simplicity of correlative models means that they require fewer resources and technical expertise. This simplicity makes correlative models useful where ecosystem service data and understanding are lacking, but their extrapolations should be treated as initial assessments. Their simplicity makes them very amenable to participatory processes. Correlative models are transferable, as done in the highly influential Costanza *et al.* (1997) study, and their recent follow up (Costanza *et al.*, 2014), which estimated the supply and value of the world's ecosystem services across a handful of broad global biomes. But the credibility of correlative models has been questioned because of their generalisation across non-similar contexts (Eigenbrod *et al.*, 2010). Typically absent in correlative methods are system dynamics such as socio-ecological feedbacks, complex interactions, temporal changes, and inclusion of external drivers of change. When these dynamics are important, or expected to play a strong role, correlative models may produce inaccurate results.

5.4.3 Process-based models

Process-based models aim to describe the ecosystem functions and biophysical processes that underlie the supply of services of benefit to people. These models can estimate the flow of ecosystem services from natural capital with more realism than correlative models. Process models can include socio-ecological feedbacks and interactions at fine scales, and therefore are very applicable to assessing the changes to ecosystem services from changes to external drivers under a management, policy or climate scenario. Examples include the use of tree growth models, combined with stand management and spatially explicit soil and climate parameters, to simulate carbon sequestration for measuring the climate regulation ecosystem service (Bryan *et al.*, 2014; Paul *et al.*, 2013). Hydrological process models have been used to link changes in land cover and land management to changes in the quantity of freshwater supply (Le Maitre *et al.*, 2007) and the quality of freshwater (Keeler *et al.*, 2012). Norton *et al.* (2012) integrated three complex process models to estimate the impact of alternative land management scenarios on freshwater quality.

Many of the process-based models of ecosystem service supply have been developed over a long time within specific scientific disciplines, such as hydrology and agronomy, that has often not been well integrated or reported in the ecosystem services literature. For example, hydrologists have for decades been modelling complex hydrological processes using detailed time-series climate and stream gauge data, often at daily time-steps over 100+ years, to simulate catchment scale rainfall-runoff dynamics and the outcome of interventions such as land use change or dam construction (e.g., CSIRO, 2008). Similarly, agronomists have built a number of crop yield simulation models using time-series climate data, soil parameters and crop management regimes, which can be used to estimate the food production ecosystem service in agro-ecosystems. A prominent example is the Agricultural Production and Simulation Model (APSIM) (Keating *et al.*, 2003).

5.4.3.1 System Dynamics Models

Integrated system dynamics models have also been used to translate biodiversity and ecosystem properties to ecosystem services and benefits, within the context of large-scale feedbacks between natural capital and human made capital. One of the earliest of these models was the Global Unified Metamodel of the Biosphere (GUMBO) (Boumans *et al.*, 2002). The GUMBO model was used by Arbault *et al.* 2014) to consider life cycle analysis. The Multiscale Integrated Earth Systems Model (MIMES) builds on the GUMBO model using a spatially explicit approach and valuation methods for most ecosystem services (Boumans *et al.*, 2015). Documentation for these models is only partially available, and they have been developed using Simile software, a commercial software package, and the code is not publically available. This current lack of documentation and code makes the models difficult to adapt, reuse, or verify, however, models developed in Simile can be exported for use in open-source software, and MIMES developers envision that the models will be available for online collaboration development in the future (Boumans *et al.*, 2015).

A wide variety of other system dynamics models have and are being constructed to address particular types of ecosystem service trade-offs, or the complex dynamics of particular places.

For example, the Land-Use Trade-Offs (LUTO) model is a complex model (Bryan *et al.*, 2014) that integrates results of other models of Australian land use change to explore economic trade-offs among agricultural provisioning services, carbon sequestration, and biodiversity conservation. The model is available, but not particularly accessible (e.g., there is no documentation available on the internet). Others have used systems approaches to model linkages among economy, society, and environment, where flows of ecosystem services provide value to both the economy and society. For example, Fiksel *et al.* (2014) have developed a Triple Value Model to represent dynamic linkages and resource flows among these three systems, as a way to characterize sustainability, however, this model was implemented in the Vensim, which is a commercial modelling toolkit, and the model is not available for download. System dynamics models are a powerful way to represent complex systems, with their feedback and interdependencies, and to examine trade-offs. The development and accessibility of these models in open-source software is an important area for future research.

5.4.3.2 Strengths and weaknesses

Process-based models' strength is that they represent scientific understanding of key dynamics, which can enable learning and rich decision assessment, while their chief weakness is that they require substantial knowledge and time to develop.

Process-based models are designed to mechanistically represent key system dynamics, which enables them to include key ecological and social feedback processes, and to evaluate alternative future management scenarios in complex situations. They can be calibrated and validated with observed data, and assessed through sensitivity and uncertainty analysis. However, they typically require substantial time to create and use. The complexity of system dynamics models and frequent lack of clear or publically available documentation often limits their use, modification and verification by others. Even when such models are freely available, the difficulty of understanding how the models function restricts their use to the modellers who initially created the model. Therefore they are often not easily transferable to other locations, except by their creators. They require detailed technical expertise to create, and cannot easily be used, analysed or modified by non-experts.

5.4.4 Expert-based models

Social ecological dynamics are often complex, integrated and poorly understood. Models of social ecological dynamics often must integrate disparate types of data and expert knowledge in the absence of mechanistic theory or quantitative data. A variety of 'soft systems' approaches have been used to model ecosystem services, including Bayesian belief networks, fuzzy cognitive maps, social-ecological scenarios and matrix models. Eliciting and using expert knowledge can be challenging, especially when multiple knowledge domains or systems of knowledge are used, and all these types of models require that expert knowledge be used in a fair, rigorous, and efficient way (Drescher et al., 2013).

5.4.4.1 Bayesian Belief Networks

Bayesian probabilistic models can be used integrate expert knowledge with multiple data sources to model flow of ecosystem services (Haines-Young, 2011; Landuyt et al., 2013). Although not themselves models that simulate biophysical processes, Bayesian models call or take outputs from biophysical models (correlative and/or process-based), and then integrate with probabilistic qualitative data often derived from expert knowledge about social systems. Integrating expert and stakeholder knowledge with quantitative data and models makes Bayesian models very useful for evaluating scenario impacts (Keshtkar et al., 2013; Fletcher et al., 2014) in situations of limited data availability and/or where there are participatory and/or co-design requirements. Landuyt et al. (2013) provide a review of 47 uses of Bayesian belief network to assess ecosystem services. This approach provides advantages of the ability to update and include additional data - which makes them useful for applications with limited data - and explicit treatment of stochastic uncertainty, but may be limited by the need for proprietary software, discretisation of the data, and the absence of feedback loops. Bayesian models are therefore proposed as a robust way to bridge the gap between the more accurate but less transferable and participatory process models, and the simple and transferable but heavily generalised correlative models (Landuyt et al., 2013).

5.4.4.2 Fuzzy Cognitive Maps

Fuzzy cognitive maps are similar to Bayesian belief networks because they combine an identification of causal links with probabilistic estimations of their impact. These models aim to capture the interactions among variables in the absence of detailed data. Typically these models are developed from discussion with experts, then iteratively revised into a model structure and function which corresponds to shared expert knowledge. For example, Daw et al. (2015) used a fuzzy cognitive map to link detailed simulation models and qualitative scenarios in a participatory workshop on coastal ecosystem services. These models can be used to make qualitative scenarios more rigorous and elicit models from diverse groups of people (Kok, 2009).

5.4.4.3 Social-Ecological Scenario Analysis

Scenario analysis is a type of soft systems modelling that has been increasingly used to analyse the dynamics of social-ecological systems, with a strong focus on ecosystems services and human well-being (Peterson et al., 2003, Oteros-Rozas et al., 2015). Scenario analysis differs from traditional quantitative models in that they are flexible, accessible, and can integrate non-quantitative, partially quantitative, or fully quantitative information (Amer et al., 2013). Social-ecological scenarios have usually analysed how decisions or policies perform across alternative futures in a way that addresses uncertainties both by improving social capacity to consider and shape the future and identify robust policies (Bennett et al., 2003; Carpenter et al., 2006a). As frameworks for integration, scenarios provide a platform for addressing and bridging different approaches to knowledge, views of how the world works, and values (Thompson et al., 2012).

Participatory scenario planning has frequently been used to address social-ecological dynamics, due to the ability of scenario planning to incorporate and engage with diverse knowledges scenarios. Prior to, but particularly since the Millennium Ecosystem Assessment (MA), a diversity of participatory social-ecological scenarios have been run in many different places around the world (Oteros-Rozas et al., 2015). These projects ranged from participatory planning

around protected areas in Spain (Palomo et al., 2011) and agricultural futures in central USA, to evaluating investments in dryland agriculture in Tanzania (Enfors et al., 2008). These projects have been used to engage diverse communities, often including indigenous people, in discussions around the management and governance of landscapes for multiple benefits. A scenario approach was used in these situations because scenarios can easily be understood as stories, and can also be used for communication and outreach, thus enriching understanding of social-ecological dynamics, uncertainties, and options (Peterson et al., 2003)

Compared to technical models, scenarios are often more accessible, integrative, and engaging; they are also better able to explicitly address trade-offs among different groups and multiple pathways between ecological change and human well-being (Carpenter et al., 2006b). However, scenarios are less rigorous, less comparable, and less generalizable than technical models. Non-participatory scenarios can often be created and analysed quickly, similar to simple expert-based models. However participatory scenario processes take longer amounts of time, and require effort similar to participatory modelling exercises (Oteros-Rozas et al., 2015). Many global assessments, as well as some smaller scenario exercises have used an iterative approach to quantitative models and qualitative storylines. In large assessments, this story and simulation approach (Alcamo et al., 2005), allows multiple complex integrated assessment models to be combined, but requires substantial amounts of coordination and expertise. It often runs into problems of consistency and an emphasis on quantitative results, even when non-modelled aspects of the scenarios may actually be more important, such as the dynamics of diet change or shifts in agricultural practices.

A number of guidebooks to conducting social-ecological scenario planning projects have been developed, but further improving the accessibility, diversity, and guidance on tools and techniques for scenario process management and scenario development is needed. Recent research has focused on combining forecasting and backcasting in scenarios (Kok et al., 2011), evaluating scenario methods, expanding scenarios from narratives, to using different media in scenario planning (Vervoort et al., 2012), and better use of softer quantitative modelling approaches such as fuzzy cognitive maps (Jetter and Kok, 2014). However, a wider use of scenario methods requires making scenario practice more accessible, which requires building a community of practice among scenario practitioners, evaluating scenario processes, and assessing the utility of different tools for different contexts and objectives (Oteros-Rozas et al., 2015).

5.4.4.4 Matrix Models

Matrix models are a common way to integrate expert opinion, land cover data, and other empirical data. Combining maps of land cover and land covers contribution to ecosystem services using Geographic Information System (GIS) and matrices allows simple and rapid exploratory ecosystem service assessment that does not require access to or training in other ecosystem service assessment models (Burkhard et al., 2009; Jacobs et al., 2015). These models estimate the capacity (i.e., ability based on ecological condition and integrity) of a landscape to supply ecosystem services, pioneered by Burkhard et al. (2009). These models have gained popularity as a pragmatic way to quantify spatiotemporal changes in supply of multiple ecosystem services under scenarios and drivers of environmental change, especially in data-sparse locations (Kaiser et al., 2013), and to meet co-design, participatory, and transdisciplinary needs inherent in ecosystem service assessments (Fish, 2011; Jacobs et al., 2015).

These features of matrix models are well illustrated by an example from Cape Town, South Africa. Responding to requests from urban politicians and land managers, O'Farrell et al. 2012 scored urban ecosystem services from remnant native vegetation in Cape Town, in which ecosystem services production by different land use classes was estimated based on expert opinion. They then analysed historical and potential future land cover change and diffuse spatial benefits away from remnant vegetation. This approach (1) allows relative cheap rapid identification of key areas and issues, (2) enables useful discussions between ecosystem service experts and urban managers, and (3) facilitates analysis of changes in land management or differences among particular sites (O'Farrell et al., 2012).

5.4.4.5 Strengths and Weaknesses

Expert-based models' significant strength is that they allow the relatively easy incorporation of diverse types of expert knowledge into ecosystem service models. This strength is particularly useful for work that seeks to bridge across multiple knowledge systems. However, this strength comes with the weakness that expert knowledge is often partial, biased, and can be incorrect, especially when applied to novel, complex or highly uncertain situations.

This weakness can be partially reduced by ensuring that the process of eliciting expert opinion is transparent, tracks where knowledge comes from and includes multiple, diverse sources of expertise. Furthermore expert-based models that can easily be combined with process-based or correlative models to allow the strengths of those models to be realized while including knowledge that is not available otherwise. The challenge is to develop easier, more effective, more transparent methods to combine these different types of knowledge in integrated approaches such as participatory social-ecological scenarios.

5.4.5 Comparing Modelling Approaches

Approaches to modelling ecosystem services vary in their analytical strengths and weaknesses as well as in the time required to apply them (Table 5.3). Correlative models focus on existing statistical relationships. Matrix models focus on spatial pattern. Fuzzy cognitive maps and Bayesian belief networks focus on representing expert knowledge.

Dynamic systems models focus on feedbacks and interactions among people and nature. Participatory scenarios combine beliefs, feedbacks and interactions based on integration of expert knowledge with models. Correlative and matrix models are easy to use, relatively easy to create and revise. These features make these types of models useful initial or rapid assessment tools. System dynamics models are difficult to produce and less accessible but allow interactions and slow dynamics to be explored. Participatory scenarios can combine many types of knowledge relatively effectively and can be easily revised, but are difficult to verify or translate from place to place.

In many local ecosystem assessments some of these approaches are combined to complement one another, but developing more standardized, tested and evaluated methodologies for integrating multiple methods is needed (Chapter 6).

Table 5.3

Comparing different types of modelling methods to ecosystem services. Many models mix different types of approaches. Participatory social-ecological scenarios often combines Expert-based models with other types of models.

<i>Modelling Approach</i>	<i>Temporal dynamics</i>	<i>Model Type</i>	<i>Ease of use</i>	<i>Time to Learn</i>	<i>Objectives</i>	<i>Beneficiaries</i>	<i>References</i>
Correlative models	No	Correlative	Easy	Medium	Multiple	Multiple	Schulp et al., 2014a
System dynamics models	Yes	Process	Hard	High	Multiple	Multiple	Boumans et al., 2015
Bayesian belief networks	No	Expert	Easy	Medium	Multiple	Multiple	Haines-Young, 2011
Fuzzy cognitive models	No	Expert	Easy	Medium	Multiple	Multiple	van Vliet et al., 2010
Matrix models	No	Expert	Easy	Low	Multiple	Single	Burkhard et al., 2009
Social-ecological scenario analysis	Yes	Expert +	Easy	Medium	Multiple	Multiple	Oteros-Rozas et al., 2015

5.4.6 Description of major ecosystem services modelling tools

Examples of some of the major models and modelling approaches for quantifying ecosystem services are compared in Table 5.4; widely used modelling tools are described more fully below. Ecosystem service models are rapidly developing, and therefore this cannot be complete comprehensive assessment of all available models. We have placed more emphasis on models and modelling frameworks that are open-access and well documented, with a substantial community of practice.

5.4.6.1 InVEST: Integrated Valuation of Ecosystem Services and Trade-offs

InVEST is a well-developed and widely applied suite of models for different types of ecosystem services, typically using the spatial extent and configuration of habitat or land use as predictors of ecosystem services production. It has been continually developed and expanded by the Natural Capital Project since 2006 (Kareiva et al., 2011). As of late 2014, the toolkit includes sixteen distinct InVEST models suited to terrestrial, freshwater, and marine ecosystems. InVEST models are typically rely on simplified representations of biophysical processes that define how an ecosystem's structure and function affect the flows and values of environmental services. InVEST models are spatially explicit and produce results in either biophysical terms, whether absolute quantities or relative magnitudes (e.g., tons of sediment retained or % of change in sediment retention) or economic terms, based on assumptions regarding future price and cost developments (e.g., the avoided treatment cost of the water affected by that change in sediment load).

InVEST's modular design and focus on scenario inputs provides an effective tool for exploring the likely outcomes of alternative management and climate scenarios and for evaluating trade-offs among sectors, services, and beneficiaries. These models are best suited for identifying spatial patterns in the provision and value of environmental services on the current landscape or under future scenarios, and trade-offs between management scenarios. With validation, these models can also provide useful estimates of the magnitude and value of services provided. Advantages of this

approach are that it is transparent, open-source, and freely accessible, with documentation and training available and an active online community forum. The spatial extent of analyses is flexible, allowing users to address questions at the local, regional or global scale. The appropriate application scale is driven primarily by the quality and resolution of input data. Uncertainty in ecosystem services estimates produced by the InVEST models may be explored by performing sensitivity analyses on model inputs (e.g., Hamel and Guswa, 2015). One model, carbon storage and sequestration, includes an automated uncertainty analysis in which users specify probability distributions for inputs and the model outputs include confidence intervals around carbon estimates.

Feedbacks are not explicitly built into the model structure, but are taken into account during the process of project scoping, model building, and implementation. For example, models are often applied in a context of scenario assessment, in which stakeholders explore the consequences of expected changes on natural resources using one or more of the InVEST service models. These scenarios typically include a map of future land use and land cover or, for marine contexts, a map of future coastal/marine uses and habitats, and uncertainties and feedbacks in the social-ecological system should be considered and articulated into the formulation of scenarios.

Based on 20 pilot demonstrations of InVEST in a diverse set of decision contexts, Ruckelshaus et al. (2015) have concluded that these simple production function models have been useful, with limitations appearing at the very small scale, and for specific future values. These models have been applied in multiple terrestrial, freshwater, and marine settings and in a range of decision contexts, including development and conservation planning, infrastructure permitting, climate adaptation planning, corporate sustainable sourcing, strategic environmental assessment, and designing payments for ecosystem services (PES) schemes. The application of InVEST for ecosystem services assessment is most effective when it is embedded within an iterative science-policy process that is broadly participatory (Rosenthal et al., 2014).

InVEST models run as stand-alone software tools, but users will need GIS software such as QGIS or ArcGIS to view results, and Python programming skills will facilitate more complex analyses such as uncertainty assessments or optimisation. Significant skill is needed to run the model, i.e., typically it will take 1-3 people two months to a year to compile data and run one or more InVEST models, although this depends on project scope and data availability. The parts of the process requiring the most time include data collection, scenario development, and iteration (i.e., re-running the models with better data and further stakeholder discussion to improve the usefulness of the models for decision-making).

InVEST provides a framework that can be adapted to the needs of specific applications. For example, Guerry et al. (2012) used the InVEST approach on the west coast of Vancouver Island in British Columbia, Canada to consider multiple services - shellfish aquaculture harvest, spatial extent of recreational kayaking, water quality, number of recreational homes, and habitat quality - under baseline conditions and scenarios of industry expansion and conservation zoning. They found that the conservation zoning would increase the production of all services except for the number of recreational float homes, whereas the industry expansion scenario would increase recreational float homes and shellfish aquaculture, having negative effects on habitat and water quality (Guerry et al., 2012). They used a valuation approach for shellfish harvest, but not for the other services considered, and they found that stakeholders found using different currencies for valuing different ecosystem services to be an acceptable approach.

5.4.6.2 ARIES: Artificial Intelligence for Ecosystem Services

Artificial Intelligence for Ecosystem Services (ARIES) is a modelling platform incorporating multi-scale process-based and probabilistic Bayesian models that has been applied in the USA, Latin America, and Africa (Villa et al., 2014). It is spatially explicit and any ecosystem services may be modelled - ARIES focuses on final benefits, to avoid possible double-counting related to the including intermediate services. Because ARIES is accessed through a web interface, commercial GIS or modelling software is not needed. A particular advantage of this approach is the flexibility to use alternative sets of models to assess a particular system. The online Ecosystem Services Explorer demo allows users to map and quantify eight different services (carbon storage and sequestration, flood regulation, coastal flood regulation, aesthetic views and proximity, freshwater supply, sediment regulation, subsistence fisheries, and recreation) in seven case study regions. A module for nutrient regulation is under development. Initial conditions are set with a Bayesian network that feeds into non-Bayesian dynamic flow models, which include feedback. ARIES uses separate model formulations to represent source and use of a service. ARIES explicitly includes the flow of services to groups of beneficiaries, using agent-based models ((Villa et al., 2014), which is useful for considering trade-offs, and for guiding policy (Bagstad et al., 2014).

ARIES is complex, and significant time and skill are required for independent applications of ARIES, and these likely require involvement of the ARIES development team as new users must be registered to use the platform. Bagstad et al. (2013a) compared an ARIES to an InVEST simulation for the San Pedro river, and estimated that the applications took 800 and 275 hours, respectively. The model has significant data requirements; however, the ARIES system assists users in locating appropriate datasets. The ARIES team envisions developing generalised global models available in future releases, which will make ARIES more accessible. However, substantial changes in the structure and use of ARIES have reduced its ability to develop a community of practice. ARIES does not include valuation, however Sherrouse et al. (2014) have used ARIES together with the Social Values for Ecosystem Services (SolVES)

tool, a GIS tool to map and quantify perceived social (non-monetary) values, including biodiversity (Sherrouse et al., 2011). The SolVES tool is freely available and can be used with other ecosystem system service models, but requires the use of GIS.

5.4.6.3 Ecopath with Ecosim (EwE)

Ecopath with Ecosim (EwE) was developed to dynamically represent energy flows through marine and aquatic ecosystems. Its structure means that it can easily include fishers and fish consumers in its models. It is one of the few ecosystem service models that explicitly represents both species and specific groups of beneficiaries however, it can only assess limited sets of usually fisheries related ecosystem services.

EwE consists of three interlinked components: Ecopath, Ecosim, and Ecospace (Christensen and Walters, 2004). First, Ecopath describes a static mass-balanced snapshot of the stocks and flows of energy (usually biomass) in an ecosystem. In typical Ecopath models, the modelled food-web is represented by functional groups that include one or multiple species with similar life history characteristics and trophic ecology and biomass removal by fishing is explicitly represented. Ecopath is described by two basic equations describing biomass production and consumption. Flows of biomass between functional groups are determined by data on diet composition.

Ecosim allows time dynamic simulation of ecosystems that are described by Ecopath. Ecosim is based on an Ecopath model to provide some of the initial-state Ecosim parameters. It uses a system of differential equations to describe the changes in biomass and flow of biomass within the system over time, by accounting for changes in predation, consumption and fishing rates (Christensen et al., 2005; Pauly et al., 2000; Walters et al., 1997). Spatial resource use of predators and preys are implicitly represented. It is primarily designed to explore fishing scenarios and their implications for the exploited ecosystems and fisheries catches. Ecosim also models the impact of environmental forcings, such as climate change, and non-trophic interactions between functional groups. Third, EcoSpace allows spatial and time dynamic simulation of Ecopath modelled ecosystems. It allows users to explore the effects of spatial fisheries management policies such as Marine Protected Areas.

Ecopath with Ecosim (EwE) has been widely used to generate scenarios of changes or management of fishing effort on flows of ecosystem services from marine ecosystems through fishing. For example, EwE modelling was applied to explore the implications of limitation of beach seine fisheries on the well-being of coastal communities in Mombasa, Kenya, with a particularly focus on the poor group (Daw et al., 2015). Specifically, EwE provided expected ecological and fisheries responses of the Mombasa coral reef and seagrass ecosystem under a range fishing effort scenarios. The model represented trophic interactions between 56 functional groups of fish and the effects of five different types of fishers using different gears, including beach seine, fish trap, spear, hook and line, and net. Simulations provided indicators of food production, profitability and conservation as well as catch per unit effort by gear and fish type. The outputs from the EwE models were used to explore human well-being implications by using a ‘toy’ fuzzy cognitive map model (5.4.3.2) to combine the key linkages of fish abundances, catches with well-being of individual stakeholders. The ‘toy’ model was used in a participatory workshop in which groups of stakeholders in the region was asked to explore ways to manage fishing effort of different gear groups that would maximise the well-being of specific fishing gear groups or seafood traders (Daw et al., 2015). There are other modelling approaches for estuarine/marine fisheries that represent additional complexity, for example the ATLANTIS model (Fulton et al., 2014). ATLANTIS uses a similar framework, but is time- and data-intensive to apply, and is used by a smaller community of practice.

5.4.6.4 IMAGE 3.0

IMAGE 3.0 is an integrated assessment modelling framework developed to analyse the dynamics of global, long-term environmental change, and sustainability problems (Stehfest et al., 2014). IMAGE contains an ecosystem service module that quantifies the supply of eight ecosystem services, using other components in the IMAGE 3.0 framework, and where necessary combined with relationships between environmental variables and ecosystem services supply, derived from literature reviews (Schulp et al., 2012). Ecosystem services derived directly from other IMAGE components include food provision from agricultural systems, water availability, carbon sequestration, and flood protection. Estimation of the ecosystem services of wild food provision, erosion risk reduction, pollination, pest control, and attractiveness for nature-based tourism, requires additional environmental variables and relationships (Maes et al., 2012a; Schulp et al., 2012), in particular fine-scale land use intensity data from the GLOBIO model (Alkemade et al., 2009). IMAGE compares the supply of different services to the estimates of the minimum quantity required by people to assess surpluses and deficiencies. This translates, for example, into minimum amounts of food and water for humans to stay healthy, or the minimum amount of natural elements in a landscape to potentially pollinate all crops. The fraction of people or land sufficiently supplied by ecosystem services is derived at different scale levels.

5.4.6.5 Other ecosystem service toolkits

Corporate Ecosystem Services Review (ESR), the Toolkit for Ecosystem Service Site-based Assessment (TESSA), Co\$ting Nature, and the Land Utilization and Capability Indicator (LUCI) are other tools that are used to quantify

ecosystem services that are based on expert or correlative models that relate ecosystem state to ecosystem services, but do not include valuation.

First is the Corporate Ecosystem Services Review (Hanson et al., 2012), developed by the World Resources Institute, which is a structured methodology that helps businesses that interact with ecosystems to identify business risks and opportunities. The Corporate Ecosystem Services Review uses a qualitative approach to consider the 27 ecosystem services given in the Millennium Ecosystem Assessment.

Second is TESSA, a toolkit that uses decision trees to guide users, through a process to rapidly prioritise ecosystem services for assessment, identify data needs, and communication approaches. It provides a template that users must adapt to specific cases (Birch et al., 2014; Peh et al., 2014).

Third is Co\$ting Nature (Mulligan et al., 2010), an easily accessible web-based tool that can be used to estimate the costs of maintaining four ecosystem services (carbon storage, water yield, nature-based tourism, and natural hazard mitigation) under scenarios of climate or land-use change. It includes detailed spatial data of the entire world, spatial models of social and biophysical processes, and scenarios of climate and land use change. Quick assessments can be made with included data, or deeper analysis using locally produced data.

Fourth is LUCI, a tool similar to Co\$ting Nature. As of late 2015, it is being revised into a second generation tool (lucitools.org). LUCI uses simple algorithms and outputs to identify and communicate ecosystem service trade-offs to stakeholder and decision makers. It is focussed on agricultural landscapes and ecosystem services such as production, carbon, flooding, erosion, sediment delivery, water quality, and habitat, based on GIS land and soil information (Jackson et al., 2013).

These toolkits are useful for providing an assessment of ecosystem services, either as a starting point for deeper modelling or scenario work or as a mechanism to connect to other ongoing analyses. The latter of these three approaches (ESR, Co\$ting Nature, and LUCI) are compared in Bagstad et al. (2013b), which assessed that ESR and Co\$ting Nature were well-suited for immediate application for scoping or assessment, and that LUCI had significant potential but was not at that time adequately documented or supported for widespread use.

5.4.6.6 Strengths and weaknesses

The widely used ecosystem service tools vary substantially in their focus, approach, and user community. Due to the differences in scale, approach, and ecosystem service focus all the models have the potential to complement one another.

In particular the easy to use rapid assessment tools can be used to provide preliminary assessments to guide deeper modelling or scenario work.

Most of these tools are only weakly dynamic, and do not incorporate ecological or social feedbacks. IMAGE and EwE both include feedbacks, but IMAGE's ecosystem service models are quite simple and EwE's focus is narrowly on fisheries related ecosystem services. While these tools are all useful for assessing current ecosystem services, and the impact of marginal changes on those services, they are not well suited for address transformative change or long term trends.

Table 5.4

Summary of major ecosystem services model tools. Dynamic models are in orange, while snapshot models are in blue.

Tool	Model Type	Scale in Space, Time	Ease of use	Community of practice	Flexibility	Reference
IMAGE	Process	Global, Dynamic	Difficult	Small	Low	Stehfest et al., 2014
EcoPath with EcoSim	Process	Region, Dynamic	Medium	Large	High	Christensen et al., 2005
ARIES	Expert	Region, Dynamic	Difficult	Small	High	Villa et al., 2014
InVEST	Process and Correlative	Region, Static	Medium	Large	Medium	Sharp et al., 2014
Co\$ting Nature	Correlative	Region, Static	Easy-Medium	Small	Medium	www.policysupport.org/costingnature

TESSA	Expert	Region, Static	Easy	Small	Low	Peh et al., 2014
Corporate Ecosystem Services Review	Expert	Region, Static	Easy	Small	Low	Hanson et al., 2012
LUCI	Correlative	Region, Static	Easy	Small	Medium	www.lucitools.org

5.4.7 Green accounting

There are a number of accounting frameworks that make explicit the contribution of ecosystems and their services to economic activity. The expansion of economic accounts to include the environment is typically referred to as green accounting (Smulders, 2008), but has other names such as triple bottom line accounting and green GDP (Boyd and Banzhaf, 2007). Green accounting approaches need to align with economic accounting approaches to avoid double counting of ecosystem services in national economic accounts. Green accounting approaches have moved from included natural capital into national accounts to explicit consideration of multiple ecosystem services.

Creating green national accounts has been approached in a number of different ways. Economic metrics that are ecologically adjusted by natural capital depletion can be produced by adjusting aggregated monetary measures of economic performance by impacts of changes to ecosystems; for example the Adjusted Net National Product (Barbier, 2012) Inclusive or comprehensive wealth accounting estimates changes in natural capital along with measures of produced human and social capital. The key idea behind wealth accounting is that the future consumption possibilities, which include non-market benefits such as some ecosystem services, depend upon the various capital types or asset base of a nation (Arrow et al., 2012; Dasgupta, 2009; UNU-IHDP and UNEP, 2014; World Bank, 2011). Other measures of economic welfare which incorporate changes in the environment that impact on human well-being, such as the Index of Sustainable Economic Welfare (Daly and Cobb, 1989) and the Genuine Progress Indicator (Kubiszewski et al., 2013). Composite indices of welfare have also sought to combine different constituents including environmental components in human well-being into a single value to represent advances in human development such as the Organisation for Economic Co-operation and Development (OECD)'s better life index (OECD, 2015).

Other approaches to green accounting have measured economic impact of alterations to ecosystems in space and time. The United Nations (UN) System of Environmental-Economic Accounting (SEEA), and the SEEA Experimental Ecosystem Accounting (SEEA-EEA) extend conventional economic accounts to the environment (EC, 2014; UN et al., 2014). The SEEA-EEA assesses the contribution of nature to economic and other human activity by organizing biophysical data, estimating ecosystem services, and tracking changes in ecosystem assets to nations (UN et al., 2014). The United States Environmental Protection Agency (US EPA)'s new National Ecosystem Services Classification System (NESCO, U.S. EPA, 2015) is a good example of how these approaches can represent ecosystem services (Figure 5.3). It is an approach designed to standardize the classification of ecosystem services to simplify their valuation, include anthropogenic assets, and clearly link ecosystem services to specific beneficiaries. It focuses on the final ecosystem services (e.g., Boyd and Banzhaf, 2007), which avoids double counting services, which is necessary for accurate economic valuation. NESCO is based on principles of accounting systems for economic goods and services, such as the North American Industry Classification System.

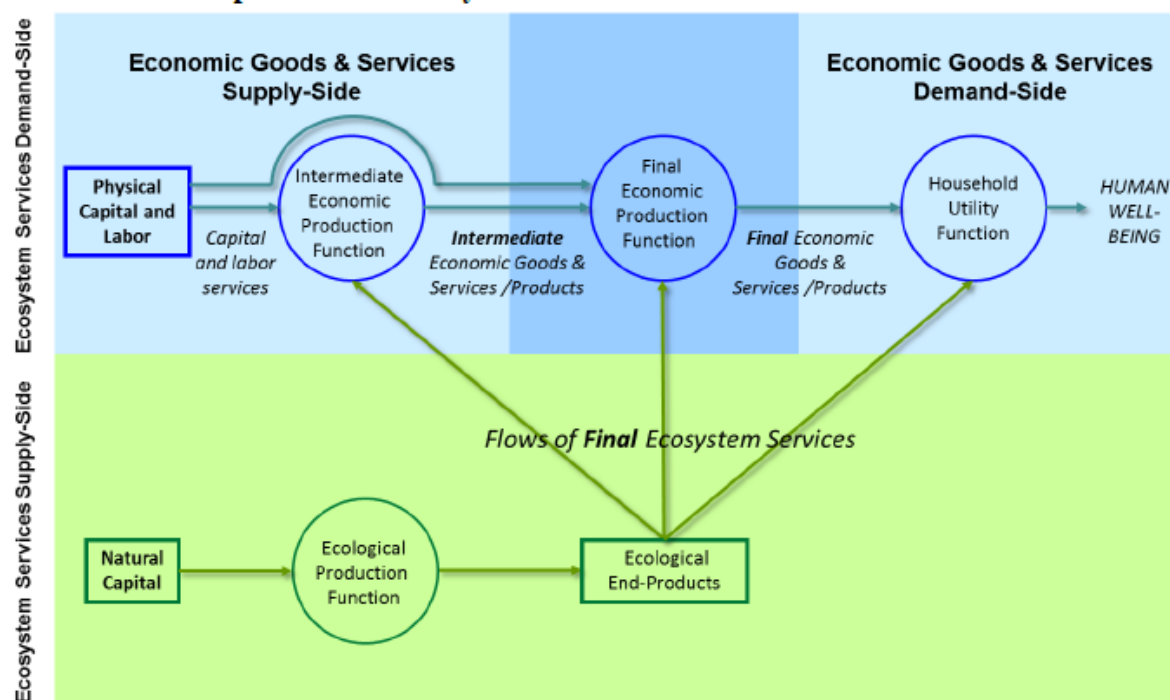

Figure 5.3: Conceptual framework for US EPA National Ecosystem Services Classification System that includes the flows of final ecosystems services as inputs into human systems (Source: U.S. EPA, 2015).

5.4.7.1 Strengths and weaknesses

Green national accounts can produce an aggregate picture of how a nation is doing, but do not disaggregate benefits and costs among different beneficiaries. Other accounting methods can link changes to individuals, but like other ecosystem service models these approaches are better at capturing immediate or marginal changes rather than longer term of systemic transformations, because they do not account for multiple social and ecological feedbacks. These accounting approaches also do not currently capture more complex aspects of human well-being, such as the influence of nature on health and well-being. Green accounting approaches rapidly developing as researchers attempt to better define practical definitions and measures of human well-being and incorporate the value of nature in national and other accounts, and they have the clear potential to complement and be combined with other ecosystem service modelling approaches.

5.5 Comparing model types across decision contexts

The variety of approaches and tools for modelling ecosystem services can be compared against how they perform in different types of decision contexts (Table 5.1). Most models of ecosystem services are focussed on making decisions, however models can also be used to as tools for dialogue, learning or evaluation. One way of simplifying the variety of decision contexts in which models can be used is the policy cycle (see Chapter 2). The policy cycle can be conceptualised as consisting of four related phases: agenda setting, policy design, implementation and review. While real world decision-making usually does not follow this idealized sequence of stages, the policy cycle helps organize discussion of different types of models. Because what decisions are being made, about what, and by who is clear in some phases of this cycle and unclear and contested in others, different approaches to modelling are required.

Modelling needs vary across the policy cycle (Figure 5.4), but most existing work on ecosystem services is focussed on the policy design stage of the cycle, while the implementation, review, and agenda setting stages are under emphasized.

Most ecosystem service models and modelling tools are designed to evaluate alternatives, but often assume clear system definition, a lack of social-ecological feedbacks, and a unified, uncontested decision-making process. While existing tools have been used as part of agenda setting, they have generally not focussed on enabling people to bridge across different knowledge systems. As Martinez-Harms et al. (2015) note, assessment of trade-offs and prioritising of management actions are key steps in decision-making for ecosystem services. However, learning and dialogue are also key aspects of decision making that have been relatively neglected by ecosystem service models. ‘Soft systems’ modelling methodologies, in particular social-ecological scenarios, have been used as learning tools. It is perhaps not surprising that ecosystem service models have not been more widely developed for learning or implementation as ecosystem services are relatively new in their application. However, there is a lot of potential to develop new modelling approaches to accelerate and improve the design of tactical models, and to develop open libraries of models

and data, as well as methods for evaluating and comparing ecosystem service models and approaches, to enable learning.

The role of models in the ecosystem service assessment process is sometimes conceptualised as a process from assessment to valuation (e.g., Bagstad et al., 2013b). However this approach solely focuses on the elaboration of the design part of the policy process, and ignores the key role of the other parts of the process that determine what is designed, as well as who gets to decide what is designed, as well as how a design is actually implemented in the real world.

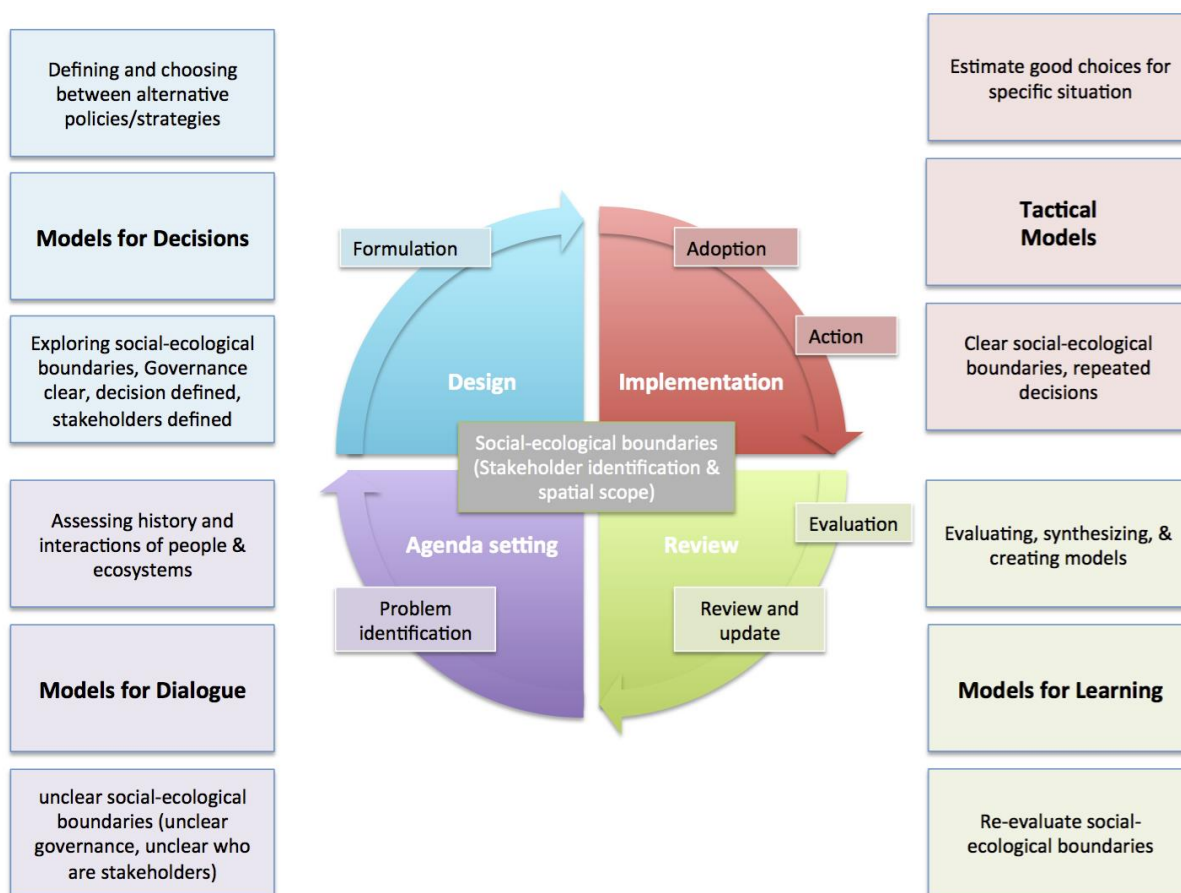

Figure 5.4: How different types of models (in bold) relate to a representation of the policy cycle (Figure 2.1). The policy cycle is conceptualised as agenda setting, policy design, implementation and review. While real world decision-making usually does not follow this idealized sequence of stages, the policy cycle helps organize discussion of different types of models. Because what decisions are being made, about what, and by who is clear in some phases of this cycle and unclear and contested in others, different approaches to modelling are required.

Participatory modelling approaches are particularly important in the agenda setting and learning parts of the policy cycle.

These parts of the policy cycle typically feature decision contexts in which a problem is unclear or contested, modelling often needs to be done in a participatory fashion. A variety of these approaches were assessed to make different useful contributions to ecosystem service assessments (Davies et al., 2015). In particular, Davies et al. (2015) found that system dynamic modelling and Bayesian belief networks, if used in isolation, have a low likelihood of generating the trust and mutual understanding necessary for people to bridge their different knowledge systems. However, more participatory modelling, including group model building, can enable people to create more integrated, shared, models of ecosystem services (Figure 5.5).

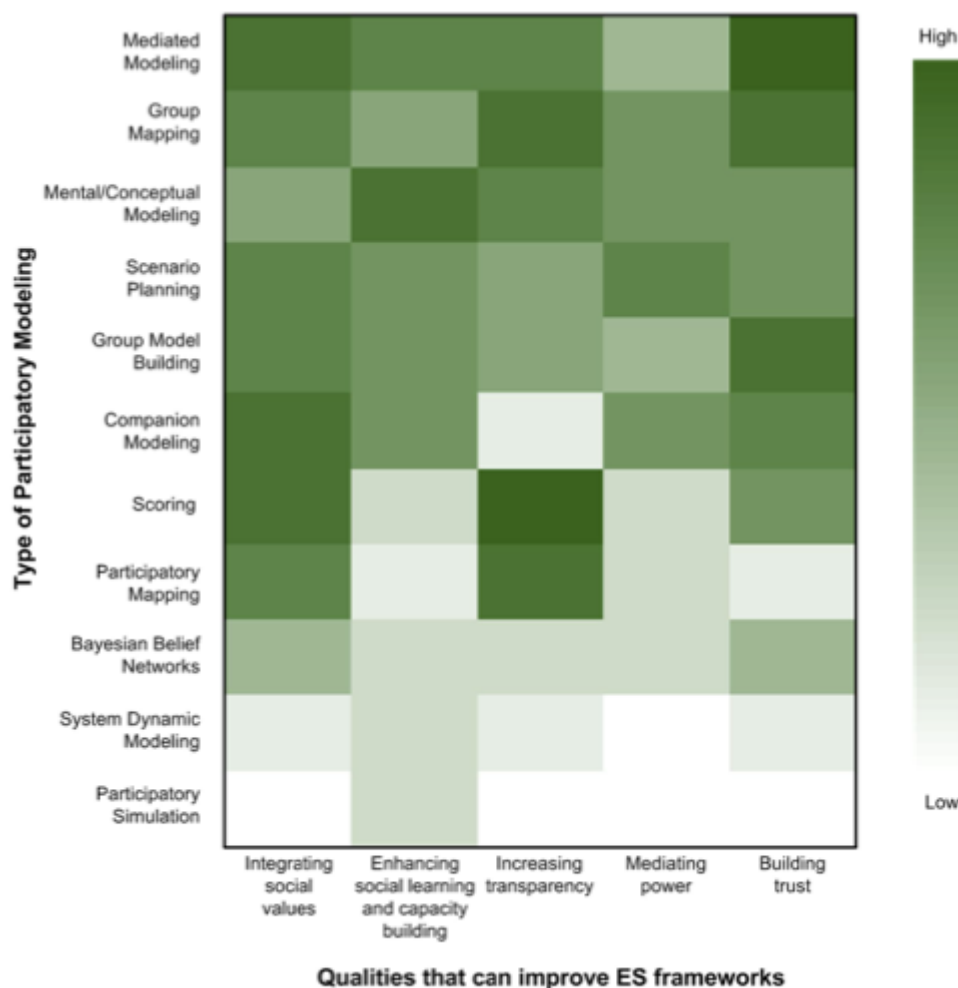

Figure 5.5: An assessment of how likely different types of participatory modelling are to contribute to the development of ecosystem service assessments in complex situations (Source: Davies et al., 2015)

There is substantial diversity among models in how they conceptualise ecosystem services in terms of whether they focus on supply (or ecosystem service potential), or the realised demand for ecosystem services, or both. Ideally, modelling approaches would consider both supply and demand, but it is difficult to define ecosystem service supply and demand in a consistent fashion due to variation in time scales, user groups, and use patterns. There is also divergence between models that quantify ecosystem services and those that attempt some type of economic valuation, and whether they link benefits to specific beneficiaries. Linking benefits to different groups of beneficiaries is possible in many models, but not frequently done in practice. It is difficult to explicitly represent these links, since sub-groups often vary in their response to changes in ecosystem services. For example, Daw et al. (2015) showed that while conservation appeared to improved fisheries ecosystem services, conservation actually reduced the ecosystem services available to some fishers if beneficiaries were disaggregated. Since links to beneficiaries can be extremely important, ecosystem service assessments need to develop this capacity.

Depending on the needs of a decision context, different modelling approaches are better suited to the task. To date there has been relatively little cross-comparison of ecosystem service models (for an exception, see Bagstad et al. (2013b)). Additionally, there have not been significant attempts to develop models to guide ecosystem service policy implementation. This gap is not surprising due to the recent rise of interest in ecosystem service policies. Finally, while existing models have been used for agenda setting, and participatory modelling has been used to assess ecosystem services, there has not been much effort to guide the development of different types of approaches to ecosystem service modelling.

Table 5.5

Development of ecosystem service models by policy phase.

Policy Cycle Phase	Agenda Setting	Design	Implementation	Learning
Model Type	Models for Dialogue	Models for Decision	Tactical Models	Models for Learning
Attributes	Articulating and bridging different perspectives	Defining and evaluating alternative policies/strategies	Identify strategies to enact policies	Evaluating, synthesizing, and creating models
Status of Models	Little developed for ES	Most developed (e.g., InVEST, ARIES, EwE)	Little developed	Little developed
Approaches	Participatory modelling; adaptive management	See Figure 5.6	Requires detailed local information, generalization difficult	Model comparison and integration (see Chapters 6 and 8)

Below we present a decision tree (Figure 5.6) that aligns the modelling approaches and tools presented here with the decision context presented in Chapter 2, using dimensions of spatial scale, and whether the model is spatially explicit; temporal scale (snapshot/single decision vs. dynamic/sequential decisions); and whether the model includes valuation. It is recognized that additional dimensions will be involved in model selection (e.g., Chapter 2, Table 2.1). Figure 5.6 shows that there are more models and approaches at the regional scale than at the global scale, and fewer of the models and approaches are dynamic in time or explicit in space.

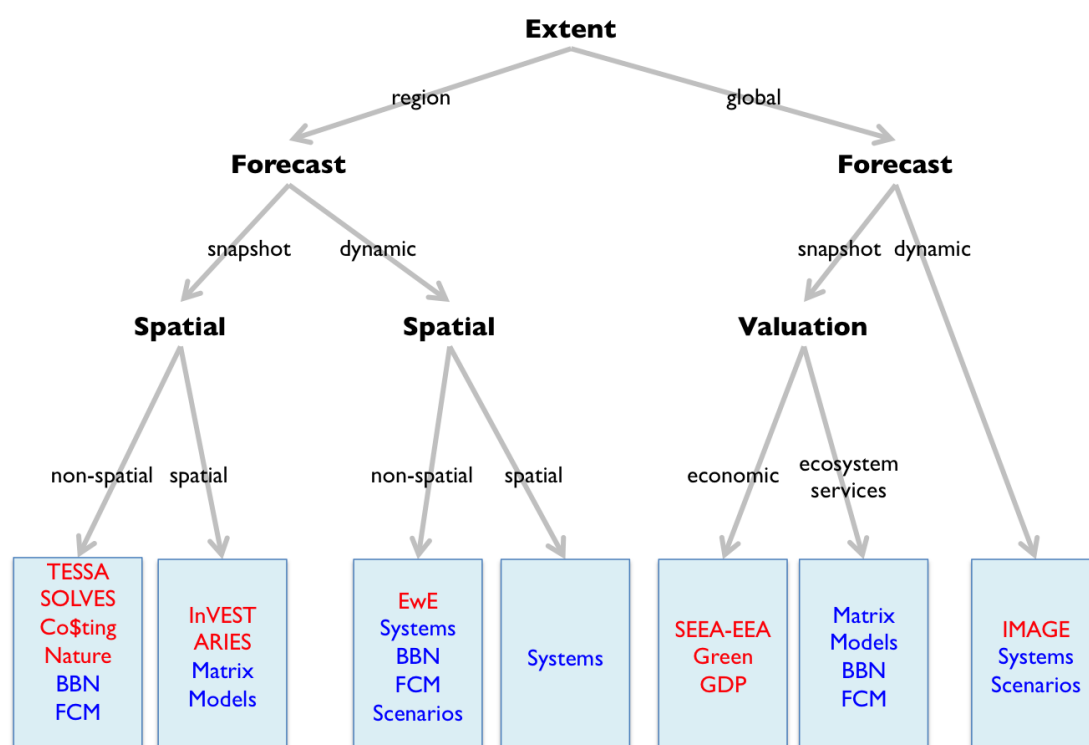

Figure 5.6: The decision tree outlines the sets of ecosystem service models that are currently available. The tree is defined by the extent of the model, type of forecast desired (snapshot or dynamic interaction among variables), and whether spatial or non-spatial analysis conducted. The boundaries between different modelling approaches are less sharp than shown in this tree, because with some effort space or time can be incorporated in snapshot or non-spatial models. Modelling approaches are shown in blue, and modelling tools are shown in red.

Currently there are no standardized modelling tools that assess how interactions among anthropogenic assets, institutions, and biodiversity produce multiple ecosystem services.

Furthermore, the tools that do exist to explore the dynamics of ecosystem services are limited in the types of ecosystem services that they can assess. While there are a variety of tools to that allow the assessment of marginal changes landscapes to ecosystem services, there is not one modelling approach that IPBES can adopt for its regional and global assessments of ecosystem services. It is unlikely that one modelling tool can be developed to forecast ecosystem services across a variety of social and ecological, but efforts to standardize, share, and cross-validate models and modelling approaches, combined with research on how to integrate models would accelerate and improve the capacity of model ecosystem services at regional scales.

5.5.1 Methods for assessing, and communicating uncertainty

Ecosystem service modelling to support decision making can be confounded by linguistic, stochastic and scientific uncertainty (defined in Chapter 1). Linguistic uncertainty in modelling arises when model parameter and variables are poorly defined or vague in their description. The development of a community of practice that clarifies and creates a shared language around key concepts and terms is essential to reduce this type of uncertainty. Specifically it can be reduced with model metadata, tutorials, and accessible published examples of model architecture and applications. Stochastic uncertainty (i.e., system variability) is the natural variation in a system, which can be quantified through probability distributions, for example produced by Monte Carlo simulations of ecosystem service models, which can then be used to derive confidence intervals and risk profiles. Understanding this type of certainty is helped by access to historical data on key variables, for example how common have extreme rainfall events been, as well as forecasts of how those drivers are likely to change in the future. Scientific uncertainty describes the lack of complete knowledge in a modelled system and its parameters - a typical feature of complex socio-ecological systems that contain non-linear relationships, unpredictable stochastic behaviour, and unknown system conditions. Although scientific uncertainty cannot be quantified, it can be reduced to statistical uncertainty by collecting more data or improving system understanding. The impact of scientific uncertainty on policy choices be reduced by using multiple models to screen and develop policies, as well as planning for surprises. Adaptive management has largely been developed to improve management in the face of all these sources of uncertainty (Walters, 1986).

Bark et al. (2013) make it clear that in ecosystem service assessments, much stochastic and scientific uncertainty exists because of the complex physical and ecological systems that underpin supply of ecosystem services, plus the large uncertainty inherent in socio-economic systems that value or demand ecosystem services. Schulp et al. (2014b) document five sources of uncertainty in ecosystem services quantified across Europe, including the following: (1) indicators, definitions and framework that classify ecosystem services; (2) level of process understanding, which leads to different quantification methods; (3) purposes of quantification that influences the selection of indicators; (4) biophysical and socio-economic input data; and (5) models used to quantify ecosystem services.

Robust communication of uncertainty has long occupied the Intergovernmental Panel on Climate Change (IPCC). For the 5th Assessment Report (Mastrandrea et al., 2010), the IPCC used an elegant system that qualitatively describes the levels of confidence in reported findings, based on expert judgement, determined through evaluation of evidence and model agreement. They also used quantitative reporting of uncertainty that stems from statistical or modelling analyses, expert opinion, or other quantitative analyses. They describe uncertainty using a likelihood scale to express a probabilistic estimate of the occurrence of a single event or outcome. A system building upon the IPCC system of describing uncertainties and confidence could be developed for modelling ecosystem services and human well-being trajectories, scenarios, and forecasts.

5.5.2 Data needs for model calibration, evaluation, and development

5.5.2.1 Data Availability

Model use and development is enhanced by the availability of data. Data availability requires both that the data exists, and that they are discoverable, accessible and usable by model developers and users. Data availability improves modelling capacity by enabling the use of more types of models, increasing the possibility of having available a model can address a problem. Data availability also decreases the difficulty of using a model, and allows models to be more easily calibrated, tested, compared and evaluated (see Chapter 8). Furthermore, data availability is essential to the creation of new types of models.

Spatial data is particularly important for both modelling ecosystem services in general and IPBES assessments in particular. In particular land use and land cover data are widely used by current ecosystem service models. Other types of data that are also used by ecosystem models include ecological, land use, political, social, infrastructure, and economic data. Ecological data include maps of species presence, vegetation communities, soil type, water, topography, and geology. Social data includes both land information such as maps of land use, land cover, and land management, as well as political data such as political boundaries at multi-scales, demographic data, such as age and gender, as well as other social data, such as health, wellbeing, and institutional membership. Useful economic data includes land values, agricultural production, tourism and recreation, wild harvest data, and estimates of

non-consumptive use values. Institutional and cultural data are likely to grow in importance for models, but are currently not widely used. However, sharing indigenous and local knowledge is often more ethically complex than sharing geophysical data, and requires different and more participatory approaches to developing databases, as such knowledge is often embedded in knowledge systems that are in political conflict, colonial monitoring, and science.

Open, free access to data greatly accelerated model calibration, evaluation, and development. Typically models require the synthesis of data from a variety of sources, and having to pay for data can block the discovery of data. Data needs are widely shared across modelling tools, consequently, free open access to data needed to define and drive ecosystem service models and scenarios has the potential to increase the ability of people to use multiple tools, better compare them, as well as create useful model analyses and scenarios. Data that is available in formats that suit particular model inputs or is easily convertible into such formats, further increases data accessibility.

Ecosystem service models also produce data that can be useful in modelling. For example, many ecosystem services have been mapped across the European Union (EU) member states; the US EPA is mapping ecosystem services in the USA with their EnviroAtlas. These and other types of model produced data are useful to test, compare, and improve with other ecosystem service models.

Open access to data allows models to build upon one another by constructing new types of synthetic data and then can be used by other modelling projects to construct need datasets. There are many examples of model synthesized open source data that are widely used in global change research, and which include data on land use and land cover as well as climate data. Developing mechanisms for sharing data among models is also vital for better linking multiple models and better linking models and qualitative narratives in scenario planning (see Chapter 6). Data availability and sharing is also essential to enable more testing and cross-validation of ecosystem service models

Open data portals that host multiple datasets make it easier for modellers to discover and use data. Several data portals are currently provided by UN and other organisations (e.g., the Food and Agriculture Organization (FAO) and the World Resources Institute (WRI)) as well as global change organizations such as the Centre for International Earth Science Information Network (CIESIN). Further improving the accessibility, interconnection, and metadata of data related to ecosystem service models and scenarios (see section on drivers) increase the ease with which models can be created. Some ecosystem service models require specific types of data, and have developed resources for sharing that data. For example, Ecopath with Ecosim requires food web data, and the community of practice using these models has developed databases of food webs that build on open databases produced by the Consultative Group for International Agricultural Research (CGIAR) fisheries researchers, as well as databases of models. Researchers are able to use these databases to develop and compare models and results. The comparison, development, and use ecosystem service models would be accelerated by making data for models, model output, and the models themselves easily accessible.

5.5.2.2 IPBES and data

The global unevenness of data and the uneven focus on ecosystem service models are two issues particularly important for IPBES.

Globally data availability is very uneven, and while some countries, such as the USA, have excellent open access to high quality social and ecological data, in many regions of the world much data is not easily available. Currently data is often most available for high income countries and the global scale. Because local and regional models use similar data but aggregated at different scales, their evaluation, use and development would be enhanced if databases of data were developed to support IPBES regional assessments, especially data that is useful for assessing ecosystem services from indigenous and local perspectives, which may not be otherwise accessible. IPBES could enhance modelling capacity in developing regions, at regional scales, by working to enhance access to data as well as developing libraries of models, and semi-automate model set-up to connect to available data. One approach is the use of web data sharing portals, such as the Ecosystem Services Partnership (ESP) spatial data mapping and sharing tool jointly developed by the European Commission Joint Research Centre and the CSIRO (see <http://esp-mapping.net/Home/>). This ESP tool allows users to upload and download spatial data on mapped ecosystem services, and query the database on what data is available for different ecosystem services and locations.

Data is primarily available for ecosystem services that are closely connected to land use. Current models focus primarily on provisioning ecosystem services and carbon and water related regulating services. There is also some focus on tourism or other recreation related cultural services. Other ecosystem services are less focussed on. For example, more locally important provisioning services, non-water or carbon related regulating services, and most cultural services are neglected. These services require different types of data, and a better understanding of how biological features and society interact to produce these services.

Developing databases to support the modelling of a broad range ecosystem services is necessary to understand the variation in ecosystem services in different locations, and enabling the creation of models that work well with indigenous and local knowledge.

5.5.3 Knowledge needs for model development, and for ongoing evaluation and calibration

5.5.3.1 Sharing knowledge for model development

A key strength of modelling tools is their ability to be adapted to new contexts. Using a modelling tool in a new context requires a flexible model, and some understanding of that context, but perhaps most importantly it requires being able to understand how to modify and use the modelling tool. Adapting a tool therefore depends on its difficulty of use and ease of learning how to use it. Even a potentially easy-to-use tool is not useful if there is no documentation or training on how to use it. Understanding how to use a tool is usually greatly facilitated by a community of practice around the tool. In general, models that are easier to use have larger communities of practice (Figure 5.7). Only two of the approaches presented in this chapter have substantial communities of practice: InVEST and EwE (Figure 5.7). Both these modelling tools are moderately complex to use, and have quite different strengths and weaknesses. EwE focuses on fishing related ecosystem services, primarily non-spatially, but with a strong focus on dynamics and different beneficiaries. InVEST is a set of interrelated models that spatially assess a broader range of individual ecosystem services, but InVEST is not dynamic and is not easily linked to multiple beneficiaries.

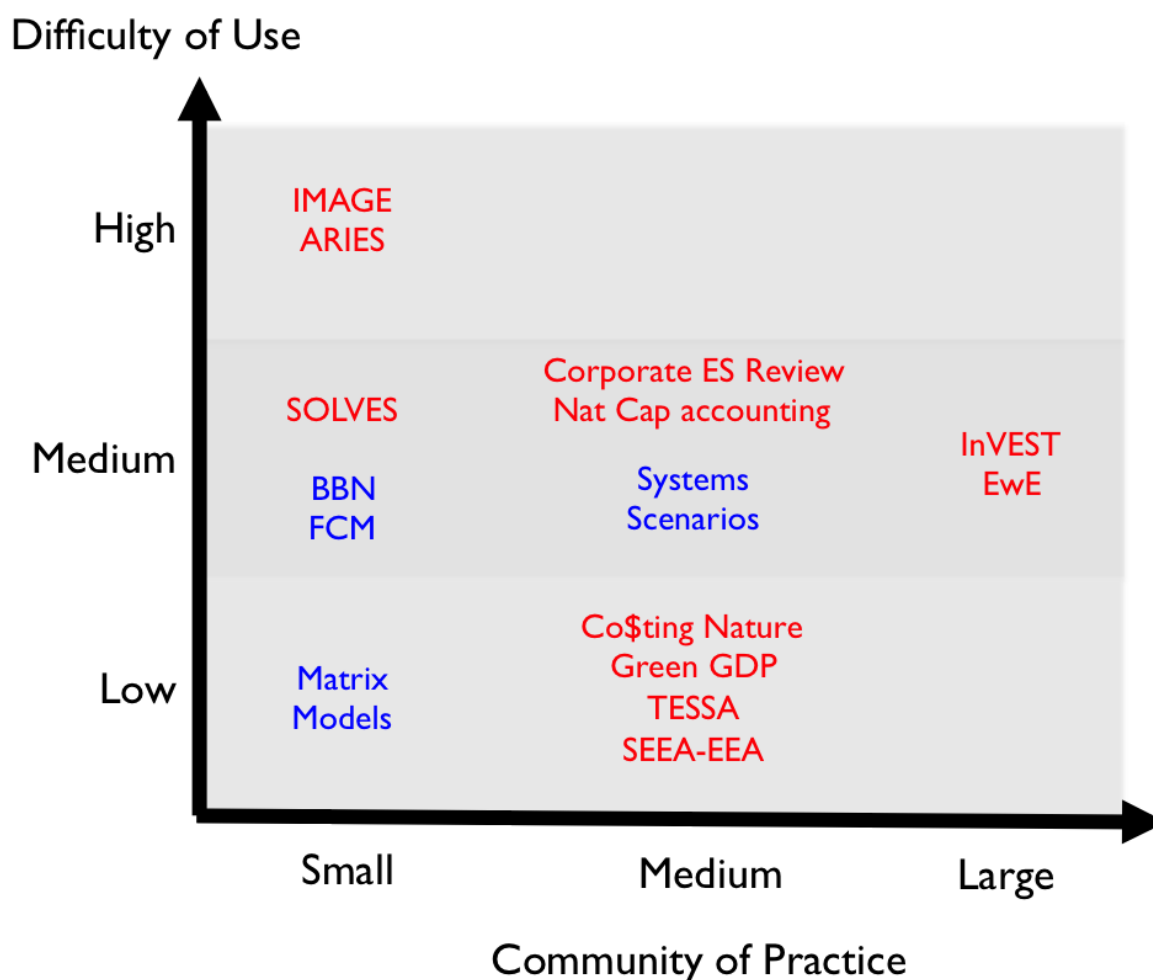

Figure 5.7: Comparison of the difficulty of use and community of practice existing for different modelling approaches (in blue) and frameworks (in red).

5.5.3.2 Developing new knowledge for model development

Following the Millennium Ecosystem Assessment, Carpenter et al. (2009) laid out a number of research challenges for ecosystem service science, which included developing models that address key social challenges, developing ability to forecast ecosystem services, modelling trade-offs among ecosystem services, being able to address non-linear and abrupt change, better modelling the diverse interactions among people and nature, and how ecosystem services interact with other factors to influence human well-being. While substantial progress has been made in developing new types of applied models and assessing trade-offs among ecosystem services, most of the other challenges remain. Two of Future Earth's research programmes, ecoServices and Programme on Ecosystem Change and Society (PECS), which are strongly related to modelling and scenarios of ecosystem services have also identified similar issues.

Future Earth's ecoService research programme aims to improve incorporation of ecosystem service research into decision-making for the sustainable use of natural resources to improve human well-being by addressing three main

research questions: (i) how are ecosystem services co-produced by social–ecological systems, (ii) who benefits from the provision of ecosystem services, and (iii) what are the best practices for the governance of ecosystem services? (Bennett et al., 2015).

Future Earth’s Programme on Ecosystem Change and Society (PECS) explores four key areas for improving ecosystem service science: (1) improving understanding and governing of social– ecological interactions between regions; (2) better understanding of long-term drivers of social-ecological change; (3) how power relations, justice, and ecosystem stewardship interact; and (4) how to better connect a diverse ecosystem service science to society (Fischer et al., 2015)

The research priorities identified by these research programmes align fairly well with the gaps we identify in this chapter. However as discussed above, there is a need to develop models for agenda setting and learning, as well as further develop models for learning that enable model testing, comparison, and verification (Table 5.5). Additionally, more strongly incorporating stakeholders, as well as indigenous and local knowledge in IPBES assessments will require using and developing models for dialogue. Addressing these research topics should significantly enhance the capacity to understand the production and dynamics of ecosystem services, and it would benefit IPBES if the issues and challenges that are identified in IPBES assessments and syntheses could be shared with these research programmes to ensure that they address these research questions in ways that enhance the capacity of IPBES. We provide more detail on four particular knowledge needs that are important to IPBES: linking biodiversity and ecosystem services, linking ecosystem services to human well-being, enhancing model transparency and accessibility, and using and integrating multiple models.

5.5.3.3 Linking biodiversity and ecosystem services

There has been rapid development in both models of biodiversity and ecosystem services over the past decade. However, these models are only weakly connected to one another, and the research communities working on biodiversity and ecosystem services are also not very connected to one another. Research on links between biodiversity and ecosystem function is one way in which connections have been strengthened between the two communities, but the accessibility of land cover, land use and other spatial data compared to functional biodiversity data has meant model development has focussed on these variables as proxies for biodiversity and biodiversity change.

There is substantial opportunity for linking, bridging and synthesizing the types of models discussed in Chapter 4 with those in Chapter 5, however because ecosystem services are co-produced by nature, institutions and anthropogenic assets these linkages require more than just using the outputs of biodiversity models as inputs into ecosystem service models.

5.5.3.4 Linking to human well-being

To date, most ecosystem model development has focused on assessing ecosystem services, with minimal attention being given to how these ecosystem services link to human well-being, especially of diverse groups of beneficiaries. Modelling the impact of ecological changes on human well-being is not well developed. This is partially because understanding of human well-being is poor, but also due the lack of involvement of human well-being researchers in ecosystem service modelling. However, some recent advances are being made. Increasing evidence demonstrates that contact with nature provides many physical and mental health benefits (Hartig et al., 2014; Bauch et al., 2015; Bratman et al., 2015; sCBD and WHO, 2015; Townsend et al., 2015; Wheeler et al., 2015; Whitmee et al., 2013). Access to parks and greenspace encourages increased physical activity and being close to parks and nature can reduce depression, anxiety and other mental health problems. Recent groundbreaking research has shown that brief nature experiences reduce neural activity in a part of the brain associated with heightened risk of mental illness (Bratman et al., 2015).

The human health benefits of experiencing nature are especially important in richer countries given the high number of people with sedentary lifestyles and associated increases in western lifestyle diseases. For example, it’s estimated that 56% of Australians have a sedentary lifestyle with very low levels of exercise. An inactive lifestyle greatly increases risk of heart attacks, strokes, type-2 diabetes, cancers and osteoporosis, which is estimated to cost the Australian economy about \$13.8 billion per year, equating to about \$1,660 per inactive person (Medibank Private 2008). A recent study estimated significant health (including 2,000 less deaths and 6,000 fewer incident cases of disease) and economic (including \$96m health sector cost savings and gain in 114,000 working days) benefits to the Australian economy of a 10% reduction in the population’s physical inactivity (Cadilhac et al., 2011).

Developing tools that better link human well-being and ecosystem services will require investment and trans-disciplinary collaboration of policy makers, with natural and social scientists to develop new frameworks, methods, and tools.

Most modelling tools have been developed to aid decision making in situations that are clearly defined and not contested (Figure 5.5), and there to develop tools that work in other types of decision contexts. Of particular relevance to IPBES are tools that allow bridging across knowledge systems and allowing indigenous and local knowledge to be

included. Particular issues that need more model development include the following: (1) assessing impact of ecological change on different groups of people, (2) incorporating different knowledge systems in modelling operation and practice, (3) considering co-production of ecosystem services as well as spatial distribution of services and beneficiaries, (4) adapting model communication for different decision contexts, (5) better incorporating social-ecological feedbacks in models, and (6) developing methods for better integrated ‘soft systems’ approaches with quantitative spatial models.

5.5.3.5 Model transparency and accessibility

For modelling approaches and tools to be widely used and trusted they should be available at no cost through open access distribution.

Even minimal cost can prevent people from assessing the utility of the tool, learning how to use it, or evaluating its performance. Some modelling tools, such as Vensim, offer version that are free for academic use or free for a period of time or with limited functionality to allow people to begin to use these tools. Other more technical tools, such as R are open access. To ensure that people not working for rich organisations have access to models, it is useful to develop models using open access or free tools, and to develop models that are themselves open access and free. Ecosystem service models should also use an open-source approach, where the model code is available. Additionally, these models should use good modelling practice, such as using standardised model description, and ensure that there is clear and accessible documentation that supports the model.

Databases of models that are available for download, especially if such models are linked to research products and clear documentation, can greatly accelerate the adaptation of modelling frameworks.

Both InVest and EwE have taken this approach for their modelling tools. An example of an open approach taken by a modelling community is the openABM project (openABM.org), which provides an excellent example of a general model database. Some journals publishing agent-based models (ABMs) require that papers must submit a version of their model with documentation to the openABM database, which makes it easier for others to learn about a model, test it, adapt it, or integrate it into a more complex model. Such practices could be an effective part of IPBES capacity building activities.

5.5.3.6 Using and integrating multiple models

A complex decision context does not necessarily require a complex model. Increase in the number of variables explicitly modelled geometrically increases the complexity of a model, thereby greatly increasing the difficulty of creating, parameterising, applying, analysing, and communicating a model.

In complex decision contexts complexity can often be addressed more simply by the application of a set of simpler models that can address complementary aspects of complexity. Alternatively, a sequential process of modelling can potentially iteratively reduce the complexity of the decision context by identifying key regions, variables, and decisions, by fostering data collection and synthesis, or by building trust, and enabling communication among different stakeholders. Figure 5.4 highlights that different phases of the policy process require models with different strengths, which suggests that IPBES assessments should consider having a toolbox of models that they use rather than attempting to identify a single model or modelling approach that is appropriate to all contexts.

5.6 Capacity building needs

The capacity of IPBES stakeholders (e.g., from local and indigenous communities, scientific communities, civil society, industries, and governments) to develop, use, or analyse models or scenarios of ecosystems services is greatly limited by the geographically uneven (1) development of ecosystem services models and scenarios science, (2) access to relevant and quality databases, (3) methods for integrating multiple knowledge systems, (4) availability of funding of such activities as well as access to (5) training on use and implementation of available tools and methodologies, and (6) communities of practice that can provide support and access to modelling tools and techniques. See Chapter 7 for a more detailed discussion of these issues.

To address the current limitations, there is a great need to (1) build communities of practice and forums (i.e., partnerships and networks) that build upon the success and lessons learned for existing communities of practice around ecosystem service tools such as InVEST and EwE, as well as other tools such as Marxan and organizations such as the Ecosystem Service Partnership and The Economics of Ecosystems and Biodiversity (TEEB), (2) develop accessible standards and documentation for models and scenario-building tools, (3) standardize and organize useful datasets models and scenario-building across various scales, such as EcoBase, which has been developed to share EwE models (Colléter et al., 2013), (4) create a dynamically updated catalogue of models and scenario building tools, that includes an evaluation of how they can fit with different decision contexts and phases of the policy cycle, (5) develop practical transdisciplinary methods for bridging multiple knowledge systems (Tengö et al., 2014) in modelling and scenario-building to enable the production of more legitimate, robust and inclusive policy recommendations and outcomes, and (6) improve accessibility to development, training, and use or applications of model and scenario tools for policy making, in particular by developing strategies to improve the ability to develop,

use and analyse these tools among indigenous and local knowledge holders, as well as among researchers in countries that lack ecosystem system service assessments.

In particular IPBES assessments have the potential to help catalyse the development of global communities of practice for ecosystem service modelling and scenario analysis (see Chapter 7 for detailed discussion), but achieving this goal will require new approaches to the design and operation of these assessments.

5.7 Summary and synthesis

This chapter offers an assessment of the rapidly changing landscape of methods assessing and forecasting the benefits that people receive from nature, and how these benefits are shaped by institutions and various anthropogenic assets. There has been an explosion of activity in understanding and modelling the benefits that people receive from nature, and this explosion has produced a diversity of approaches that are both complementary and contradictory. However, there remain major gaps in what current models can do. They are not well suited to estimate most types of benefits at national, regional, or global scales. They are focused on decision analysis, but have not focussed on implementation, learning, or dialogue. This gap in particular means that current models are not well suited to bridging among multiple knowledge systems, however, there are initial efforts made towards this there appears to be a clear demand for this type of activity. Furthermore, while participatory social-ecological scenarios are able to bridge multiple knowledge systems in their assessment and analysis of multiple ecosystem services, the social-ecological scenarios community is fragmented and not well connected. Consequently, IPBES has an excellent knowledge base to build upon, but a real investment in building a more integrated modelling and scenarios community of practice is needed to produce a more complete and useful toolbox of approaches to meet the needs of IPBES assessments and other assessments of nature's benefits.

References

- Abram, N.K., Meijaard, E., Ancrenaz, M., Runting, R.K., Wells, J.A., Gaveau, D., Pellier, A.S. and Mengersen, K., 2014: Spatially explicit perceptions of ecosystem services and land cover change in forested regions of Borneo. *Ecosystem Services*, **7**: 116-127.
- Alcamo, J., Van Vuuren, D., Cramer, W., Alder, J., Bennett, E., Carpenter, S., Christensen, V., Foley, J., Maerker, M., Masui, T. and others, 2005: Changes in ecosystem services and their drivers across the scenarios. *Ecosystems and human well-being*, **2**: 297-373.
- Alkemade, R., Van Oorschot, M., Miles, L., Nellemann, C., Bakkenes, M. and ten Brink, B., 2009: GLOBIO3: A Framework to Investigate Options for Reducing Global Terrestrial Biodiversity Loss. *Ecosystems*, **12**(3): 374-390.
- Amer, M., Daim, T.U. and Jetter, A., 2013: A review of scenario planning. *Futures*, **46**: 23-40.
- Arrow, K.J., Dasgupta, P., Goulder, L.H., Mumford, K.J. and Oleson, K., 2012: Sustainability and the measurement of wealth. *Environment and Development Economics*, **17**(3): 317-353.
- Bagstad, K.J., Semmens, D.J. and Winthrop, R., 2013a: Comparing approaches to spatially explicit ecosystem service modeling: A case study from the San Pedro River, Arizona. *Ecosystem Services*, **5**: 40-50.
- Bagstad, K.J., Semmens, D.J., Waage, S. and Winthrop, R., 2013b: A comparative assessment of decision-support tools for ecosystem services quantification and valuation. *Ecosystem Services*, **5**: 27-39.
- Bagstad, K.J., Villa, F., Batker, D., Harrison-Cox, J., Voigt, B. and Johnson, G.W., 2014: From theoretical to actual ecosystem services: mapping beneficiaries and spatial flows in ecosystem service assessments. *Ecology and Society*, **19**(2).
- Barbier, E.B., 2012: Ecosystem services and wealth accounting. In *Inclusive Wealth Report 2012. Measuring progress toward sustainability.*, UNU-IHDP and UNEP, eds., Cambridge, Cambridge University Press.
- Bark, R.H., Peeters, L.J.M., Lester, R.E., Pollino, C.A., Crossman, N.D. and Kandulu, J.M., 2013: Understanding the sources of uncertainty to reduce the risks of undesirable outcomes in large-scale freshwater ecosystem restoration projects: An example from the Murray–Darling Basin, Australia. *Environmental science & policy*, **33**: 97-108.
- Bateman, I.J., Harwood, A.R., Mace, G.M., Watson, R.T., Abson, D.J., Andrews, B., Binner, A., Crowe, A., Day, B.H., Dugdale, S., Fezzi, C., Foden, J., Hadley, D., Haines-Young, R., Hulme, M., Kontoleon, A., Lovett, A.A., Munday, P., Pascual, U., Paterson, J., Perino, G., Sen, A., Siriwardena, G., van Soest, D. and Termansen, M., 2013: Bringing Ecosystem Services into Economic Decision-Making: Land Use in the United Kingdom. *Science*, **341**(6141): 45-50.
- Bauch, S.C., Birkenbach, A.M., Pattanayak, S.K. and Sills, E.O., 2015: Public health impacts of ecosystem change in the Brazilian Amazon. *Proceedings of The National Academy of Sciences*, **112**(24): 7414-7419.
- Bennett, E.M., Peterson, G.D. and Gordon, L.J., 2009: Understanding relationships among multiple ecosystem services. *Ecology Letters*, **12**: 1394--1404.
- Bennett, E.M., Carpenter, S.R., Peterson, G.D., Cumming, G.S., Zurek, M. and Pingali, P., 2003: Why global scenarios need ecology. *Frontiers in Ecology and the Environment*, **1**: 322--329.
- Bennett, E.M., Cramer, W., Begossi, A., Cundill, G., Díaz, S., Egoh, B.N., Gejzendorffer, I.R., Krug, C.B., Lavorel, S., Lazos, E., Lebel, L., Martín-López, B., Meyfroidt, P., Mooney, H.A., Nel, J.L., Pascual, U., Payet, K., Harguindeguy, N.P., Peterson, G.D., Prieur-Richard, A.-H., Reyers, B., Roebeling, P., Seppelt, R., Solan, M., Tschakert, P., Tschardtke, T., Turner, I., B.L., Verburg, P.H., Viglizzo, E.F., White, P.C.L. and Woodward, G., 2015: Linking biodiversity, ecosystem services, and human well-being: three challenges for designing research for sustainability. *Current opinion in environmental sustainability*, **14**: 76-85.
- Birch, J.C., Thapa, I., Balmford, A., Bradbury, R.B., Brown, C., Butchart, S.H.M., Gurung, H., Hughes, F.M.R., Mulligan, M., Pandeya, B., Peh, K.S.H., Stattersfield, A.J., Walpole, M. and Thomas, D.H.L., 2014: What benefits do community forests provide, and to whom? A rapid assessment of ecosystem services from a Himalayan forest, Nepal. *Ecosystem Services*, **8**: 118-127.
- Boumans, R., Roman, J., Altman, I. and Kaufman, L., 2015: The Multiscale Integrated Model of Ecosystem Services (MIMES): Simulating the interactions of coupled human and natural systems. *Ecosystem Services*, **12**: 30-41.
- Boumans, R., Costanza, R., Farley, J., Wilson, M.A., Portela, R., Rotmans, J., Villa, F. and Grasso, M., 2002: Modeling the dynamics of the integrated earth system and the value of global ecosystem services using the GUMBO model. *Ecological Economics*, **41**(3): 529-560.

- Boyd, J. and Banzhaf, S., 2007: What are ecosystem services? The need for standardized environmental accounting units. *Ecological Economics*, **63**(2–3): 616-626.
- Bratman, G.N., Hamilton, J.P., Hahn, K.S., Daily, G.C. and Gross, J.J., 2015: Nature experience reduces rumination and subgenual prefrontal cortex activation. *Proceedings of The National Academy of Sciences*, **112**(28): 8567-8572.
- Bryan, B.A. and Crossman, N.D., 2013: Impact of multiple interacting financial incentives on land use change and the supply of ecosystem services. *Ecosystem Services*, **4**: 60-72.
- Bryan, B.A., Nolan, M., Harwood, T.D., Connor, J.D., Navarro-Garcia, J., King, D., Summers, D.M., Newth, D., Cai, Y., Grigg, N., Harman, I., Crossman, N.D., Grundy, M.J., Finnigan, J.J., Ferrier, S., Williams, K.J., Wilson, K.A., Law, E.A. and Hatfield-Dodds, S., 2014: Supply of carbon sequestration and biodiversity services from Australia's agricultural land under global change. *Global Environmental Change*, **28**: 166-181.
- Burkhard, B., Kroll, F., Müller, F. and Windhorst, W., 2009: Landscapes' Capacities to Provide Ecosystem Services - a Concept for Land-Cover Based Assessments. *Landscape Online*, **15**: 1-22.
- Butler, C.D. and Oluoch-Kosura, W., 2006: Linking future ecosystem services and future human well-being. *Ecology and Society*, **11**(1): 30.
- Cadilhac, D.A., Cumming, T.B., Sheppard, L., Pearce, D.C., Carter, R. and Magnus, A., 2011: The economic benefits of reducing physical inactivity: an Australian example. *International Journal of Behavioral Nutrition and Physical Activity*, **8**: 99.
- Cardinale, B.J., Duffy, J.E., Gonzalez, A., Hooper, D.U., Perrings, C., Venail, P., Narwani, A., Mace, G.M., Tilman, D., Wardle, D.A., Kinzig, A.P., Daily, G.C., Loreau, M., Grace, J.B., Larigauderie, A., Srivastava, D.S. and Naeem, S., 2012: Biodiversity loss and its impact on humanity. *Nature*, **486**(7401): 59-67.
- Carpenter, S.R., Bennett, E.M. and Peterson, G.D., 2006a: Scenarios for ecosystem services: an overview. *Ecology and Society*, **11**(1): 29.
- Carpenter, S.R., De Fries, R., Dietz, T., Mooney, H.A., Polasky, S., Reid, W.V. and Scholes, R.J., 2006b: Millennium ecosystem assessment: research needs. *Science*, **314**: 257-258.
- Carpenter, S.R., Mooney, H.A., Agard, J., Capistrano, D., Defries, R.S., Díaz, S., Dietz, T., Duraiappah, A.K., Oteng-Yeboah, A., Pereira, H.M., Perrings, C., Reid, W.V., Sarukhan, J., Scholes, R.J. and Whyte, A., 2009: Science for managing ecosystem services: Beyond the Millennium Ecosystem Assessment. *Proceedings of The National Academy of Sciences*, **106**: 1305-1312.
- Chan, K.M.A., Shaw, M.R., Cameron, D.R., Underwood, E.C. and Daily, G.C., 2006: Conservation planning for ecosystem services. *PLoS Biology*, **4**: 2138-2152.
- Christensen, V. and Walters, C.J., 2004: Ecopath with Ecosim: methods, capabilities and limitations. *Ecological Modelling*, **172**(2-4): 109-139.
- Christensen, V., Walters, C.J. and Pauly, D., 2005: *Ecopath with Ecosim: A User's Guide*. Vancouver, Canada, Fisheries Centre, University of British Columbia.
- Colléter, M., Valls, A., Guitton, J., Morissette, L., Arreguín-Sánchez, F., Christensen, V., Gascuel, D. and Pauly, D., 2013: EcoBase: a repository solution to gather and communicate information from EwE models. Fisheries Centre, University of British Columbia, Fisheries Centre Research Reports, Vancouver, British Columbia, Canada.
- Costanza, R., Cumberland, J.H., Daly, H., Goodland, R., Norgaard, R.B., Kubiszewski, I. and Franco, C., 2014: *An introduction to ecological economics*. CRC Press.
- Costanza, R., d'Arge, R., de Groot, R., Farber, S., Grasso, M., Hannon, B., Limburg, K., Naeem, S., O'Neill, R.V., Paruelo, J., Raskin, R.G., Sutton, P. and van den Belt, M., 1997: The value of the world's ecosystem services and natural capital. *Nature*, **387**(6630): 253-260.
- Crossman, N.D., Bryan, B.A., de Groot, R.S., Lin, Y.-P. and Minang, P.A., 2013a: Land science contributions to ecosystem services. *Current opinion in environmental sustainability*, **5**(5): 509-514.
- Crossman, N.D., Burkhard, B., Nedkov, S., Willemsen, L., Petz, K., Palomo, I., Drakou, E.G., Martín-Lopez, B., McPhearson, T., Boyanova, K., Alkemade, R., Egoh, B., Dunbar, M.B. and Maes, J., 2013b: A blueprint for mapping and modelling ecosystem services. *Ecosystem Services*, **4**: 4-14.
- CSIRO, 2008: Water Availability in the Murray-Darling Basin. A report to the Australian Government from the CSIRO Murray-Darling Sustainable Yields Project. CSIRO Australia, 67.

- Cuddington, K., Fortin, M.J., Gerber, L.R., Hastings, A., Liebhold, A., O'Connor, M.I. and Ray, C., 2013: Process-based models are required to manage ecological systems in a changing world. *Ecosphere*, **4**(2): 20.
- Cumming, G.S., Buerkert, A., Hoffmann, E.M., Schlecht, E., von Cramon-Taubadel, S. and Tschardtke, T., 2014: Implications of agricultural transitions and urbanization for ecosystem services. *Nature*, **515**(7525): 50-57.
- Daly, H.E. and Cobb, J.B., 1989: *For the common good: redirecting the economy toward community, the environment, and a sustainable future*. Beacon, Boston, MA.
- Dasgupta, P., 2009: The welfare economic theory of green national accounts. *Environmental and Resource Economics*, **42**(1): 3-38.
- Davies, K.K., Fisher, K.T., Dickson, M.E., Thrush, S.F. and Le Heron, R., 2015: Improving ecosystem service frameworks to address wicked problems. *Ecology and Society*, **20**(2).
- Daw, T.M., Coulthard, S., Cheung, W.W.L., Brown, K., Abunge, C., Galafassi, D., Peterson, G.D., McClanahan, T.R., Omukoto, J.O. and Munyi, L., 2015: Evaluating taboo trade-offs in ecosystems services and human well-being. *Proceedings of The National Academy of Sciences*, **112**(22): 6949-6954.
- Díaz, S., Demissew, S., Carabias, J., Joly, C., Lonsdale, M., Ash, N., Larigauderie, A., Adhikari, J.R., Arico, S., Báldi, A., Bartuska, A., Baste, I.A., Bilgin, A., Brondizio, E., Chan, K.M.A., Figueroa, V.E., Duraiappah, A., Fischer, M., Hill, R., Koetz, T., Leadley, P., Lyver, P., Mace, G.M., Martin-Lopez, B., Okumura, M., Pacheco, D., Pascual, U., Pérez, E.S., Reyers, B., Roth, E., Saito, O., Scholes, R.J., Sharma, N., Tallis, H., Thaman, R., Watson, R., Yahara, T., Hamid, Z.A., Akosim, C., Al-Hafedh, Y., Allahverdiyev, R., Amankwah, E., Asah, S.T., Asfaw, Z., Bartus, G., Brooks, L.A., Caillaux, J., Dalle, G., Darnaedi, D., Driver, A., Erpul, G., Escobar-Eyzaguirre, P., Failler, P., Fouda, A.M.M., Fu, B., Gundimeda, H., Hashimoto, S., Homer, F., Lavorel, S., Lichtenstein, G., Mala, W.A., Mandivenyi, W., Matczak, P., Mbizvo, C., Mehrdadi, M., Metzger, J.P., Mikissa, J.B., Moller, H., Mooney, H.A., Mumby, P., Nagendra, H., Nesshover, C., Oteng-Yeboah, A.A., Pataki, G., Roué, M., Rubis, J., Schultz, M., Smith, P., Sumaila, R., Takeuchi, K., Thomas, S., Verma, M., Yeo-Chang, Y. and Zlatanova, D., 2015: The IPBES Conceptual Framework — connecting nature and people. *Current opinion in environmental sustainability*, **14**: 1-16.
- Drescher, M., Perera, A.H., Johnson, C.J., Buse, L.J., Drew, C.A. and Burgman, M.A., 2013: Toward rigorous use of expert knowledge in ecological research. *Ecosphere*, **4**(7): art83.
- EC, 2014: Mapping and Assessment of Ecosystems and their Services: Indicators for ecosystem assessments under Action 5 of the EU Biodiversity Strategy 2020. European Commission, Technical Report 080,
- Egoh, B., Reyers, B., Carwardine, J., Bode, M., O'Farrell, P., Wilson, K., Possingham, H., Rouget, M., De lange, W., Richardson, D.m. and Cowling, R., 2010: Safeguarding Biodiversity and Ecosystem Services in the Little Karoo, South Africa. *Conservation Biology*, **24**(4): 1021-1030.
- Eigenbrod, F., Armsworth, P.R., Anderson, B.J., Heinemeyer, A., Gillings, S., Roy, D.B., Thomas, C.D. and Gaston, K.J., 2010: The impact of proxy-based methods on mapping the distribution of ecosystem services. *Journal of Applied Ecology*, **47**: 377-385.
- Enfors, E.I., Gordon, L.J., Peterson, G.D. and Bossio, D., 2008: Making Investments in Dryland Development Work: Participatory Scenario Planning in the Makanya Catchment, Tanzania. *Ecology and Society*, **13**(2).
- Fiksel, J., Bruins, R., Gatchett, A., Gilliland, A. and ten Brink, M., 2014: The triple value model: a systems approach to sustainable solutions. *Clean Technologies and Environmental Policy*, **16**(4): 691-702.
- Fischer, J., Gardner, T.A., Bennett, E.M., Balvanera, P., Biggs, R., Carpenter, S., Daw, T., Folke, C., Hill, R., Hughes, T.P., Luthe, T., Maass, M., Meacham, M., Norström, A.V., Peterson, G., Queiroz, C., Seppelt, R., Spierenburg, M. and Tenhunen, J., 2015: Advancing sustainability through mainstreaming a social–ecological systems perspective. *Current opinion in environmental sustainability*, **14**: 144-149.
- Fish, R.D., 2011: Environmental decision making and an ecosystems approach: Some challenges from the perspective of social science. *Progress in Physical Geography*, **35**: 671-680.
- Fletcher, P.J., Kelble, C.R., Nuttle, W.K. and Kiker, G.A., 2014: Using the integrated ecosystem assessment framework to build consensus and transfer information to managers. *Ecological Indicators*, **44**: 11-25.
- Fremier, A.K., DeClerck, F.A.J., Bosque-Pérez, N.A., Carmona, N.E., Hill, R., Joyal, T., Keesecker, L., Klos, P.Z., Martínez-Salinas, A., Niemeyer, R., Sanfiorenzo, A., Welsh, K. and Wulforst, J.D., 2013: Understanding Spatiotemporal Lags in Ecosystem Services to Improve Incentives. *Bioscience*, **63**(6): 472-482.
- Fulton, E.A., Smith, A.D.M., Smith, D.C. and Johnson, P., 2014: An Integrated Approach Is Needed for Ecosystem Based Fisheries Management: Insights from Ecosystem-Level Management Strategy Evaluation. *PLoS ONE*, **9**(1): e84242.

- Guerry, A.D., Ruckelshaus, M.H., Arkema, K.K., Bernhardt, J.R., Guannel, G., Kim, C.-K., Marsik, M., Papenfus, M., Toft, J.E., Verutes, G., Wood, S.a., Beck, M., Chan, F., Chan, K.M.a., Gelfenbaum, G., Gold, B.D., Halpern, B.S., Labiosa, W.B., Lester, S.E., Levin, P.S., McField, M., Pinsky, M.L., Plummer, M., Polasky, S., Ruggiero, P., Sutherland, D.a., Tallis, H., Day, A. and Spencer, J., 2012: Modeling benefits from nature: using ecosystem services to inform coastal and marine spatial planning. *International Journal of Biodiversity Science, Ecosystem Services & Management*, **8**(1-2): 107-121.
- Haines-Young, R., 2011: Exploring ecosystem service issues across diverse knowledge domains using Bayesian Belief Networks. *Progress in Physical Geography*, **35**(5): 681-699.
- Hamel, P. and Guswa, A.J., 2015: Uncertainty analysis of a spatially explicit annual water-balance model: case study of the Cape Fear basin, North Carolina. *Hydrol. Earth Syst. Sci.*, **19**(2): 839-853.
- Hanson, C., Ranganathan, J., Iceland, C. and Finisdore, J., 2012: The Corporate Ecosystem Services Review: Guidelines for identifying business risks and opportunities arising from ecosystem change (version 2.0) <http://www.wri.org/publication/corporate-ecosystem-services-review> USA.
- Hartig, T., Mitchell, R., de Vries, S. and Frumkin, H., 2014: Nature and Health. *Annual Review of Public Health*, **35**(1): 207-228.
- Houde, N., 2007: The six faces of traditional ecological knowledge: Challenges and opportunities for Canadian co-management arrangements. *Ecology and Society*, **12**(2): 17-17.
- Jackson, B., Pagella, T., Sinclair, F., Orellana, B., Genshaw, A., McIntyre, N., Reynolds, B., Wheeler, H. and Eycott, A., 2013: Polyscape: a GIS mapping toolbox providing efficient and spatially explicit landscape-scale valuation of multiple ecosystem services. *Urban and Landscape Planning*, (112): 74-88.
- Jacobs, S., Burkhard, B., Van Daele, T., Staes, J. and Schneiders, A., 2015: 'The Matrix Reloaded': A review of expert knowledge use for mapping ecosystem services. *Ecological Modelling*, **295**: 21-30.
- Jetter, A.J. and Kok, K., 2014: Fuzzy Cognitive Maps for futures studies—A methodological assessment of concepts and methods. *Futures*, **61**: 45-57.
- Kaiser, G., Burkhard, B., Römer, H., Sangkaew, S., Graterol, R., Haitook, T., Sterr, H. and Sakuna-Schwartz, D., 2013: Mapping tsunami impacts on land cover and related ecosystem service supply in Phang Nga, Thailand. *Nat. Hazards Earth Syst. Sci.*, **13**(12): 3095-3111.
- Kareiva, P., Tallis, H., Ricketts, T.H., Daily, G.C. and Polasky, S., 2011: *Natural Capital: Theory and Practice of Mapping Ecosystem Services*. Oxford, UK., Oxford University Press.
- Keating, B.A., Carberry, P.S., Hammer, G.L., Probert, M.E., Robertson, M.J., Holzworth, D., Huth, N.I., Hargreaves, J.N.G., Meinke, H., Hochman, Z., McLean, G., Verburg, K., Snow, V., Dimes, J.P., Silburn, M., Wang, E., Brown, S., Bristow, K.L., Asseng, S., Chapman, S., McCown, R.L., Freebairn, D.M. and Smith, C.J., 2003: An overview of APSIM, a model designed for farming systems simulation. *European Journal of Agronomy*, **18**(3-4): 267-288.
- Keeler, B.L., Polasky, S., Brauman, K.A., Johnson, K.A., Finlay, J.C., O'Neill, A., Kovacs, K. and Dalzell, B., 2012: Linking water quality and well-being for improved assessment and valuation of ecosystem services. *Proceedings of The National Academy of Sciences*, **109**(45): 18619-18624.
- Keshtkar, A.R., Salajegheh, A., Sadoddin, A. and Allan, M.G., 2013: Application of Bayesian networks for sustainability assessment in catchment modeling and management (Case study: The Hablehrood river catchment). *Ecological Modelling*, **268**: 48-54.
- Kok, K., 2009: The potential of Fuzzy Cognitive Maps for semi-quantitative scenario development, with an example from Brazil. *Global Environmental Change*, **19**(1): 122-133.
- Kok, K., van Vliet, M., Bärlund, I., Dubel, A. and Sendzimir, J., 2011: Combining participative backcasting and exploratory scenario development: experiences from the SCENES project. *Technological Forecasting and Social Change*, **78**(5): 835-851.
- Kubiszewski, I., Costanza, R., Franco, C., Lawn, P., Talberth, J., Jackson, T. and Aylmer, C., 2013: Beyond GDP: Measuring and achieving global genuine progress. *Ecological Economics*, **93**(0): 57-68.
- Landuyt, D., Broekx, S., D'Hondt, R., Engelen, G., Aertsens, J. and Goethals, P.L.M., 2013: A review of Bayesian belief networks in ecosystem service modelling. *Environmental Modelling & Software*, **46**: 1-11.
- Le Maitre, D.C., Milton, S.J., Jarman, C., Colvin, C.A., Saayman, I. and Vlok, J.H.J., 2007: Linking ecosystem services and water resources: landscape-scale hydrology of the Little Karoo. *Frontiers in Ecology and the Environment*, **5**(5): 261-270.
- MA, 2005a: *Ecosystems and Human Well-being: Synthesis*. Washington, DC, Island Press.

- MA, 2005b: *Ecosystems and Human Well-being: Scenarios, Volume 2*. Washington, DC, Island Press.
- Maes, J., Crossman, N.D. and Burkhard, B., 2016: Mapping ecosystem services. In *Handbook on Ecosystem Services*, Haines-Young R, P.M.F.R. and Turner, K., eds., United Kingdom, Earthscan from Routledge.
- Maes, J., Paracchini, M.L., Zulian, G., Dunbar, M.B. and Alkemade, R., 2012a: Synergies and trade-offs between ecosystem service supply, biodiversity, and habitat conservation status in Europe. *Biological Conservation*, **155**: 1-12.
- Maes, J., Egoh, B., Willemsen, L., Liqueste, C., Vihervaara, P., Schägner, J.P., Grizzetti, B., Drakou, E.G., Notte, A.L., Zulian, G., Bouraoui, F., Luisa Paracchini, M., Braat, L. and Bidoglio, G., 2012b: Mapping ecosystem services for policy support and decision making in the European Union. *Ecosystem Services*, **1**(1): 31-39.
- Martinez-Harms, M.J., Bryan, B.A., Balvanera, P., Law, E.A., Rhodes, J.R., Possingham, H.P. and Wilson, K.A., 2015: Making decisions for managing ecosystem services. *Biological Conservation*, **184**: 229-238.
- Mastrandrea, M.D., Field, C.B., Stocker, T.F., Edenhofer, O., Ebi, K.L., Frame, D.J., Held, H., Kriegler, E.M., Matschoss, P.R., Plattner, G.K., Yohe, G.W. and Zwiers, F.W., 2010: Guidance Note for Lead Authors of the IPCC Fifth Assessment Report on Consistent Treatment of Uncertainties. Intergovernmental Panel on Climate Change (IPCC).
- Mulligan, M., Guerry, A., Arkema, K., Bagstad, K. and Villa, F., 2010: Capturing and quantifying the flow of ecosystem services. In *Framing the flow: Innovative Approaches to Understand, Protect and Value Ecosystem Services Across Linked Habitats*, Silvestri, S. and Kershaw, F., eds., Cambridge, UK, UNEP World Conservation Monitoring Centre.
- Nassl, M. and Löffler, J., 2015: Ecosystem services in coupled social–ecological systems: Closing the cycle of service provision and societal feedback. *Ambio*: 1-13.
- Nelson, E., Mendoza, G., Regetz, J., Polasky, S., Tallis, H., Cameron, D., Chan, K.M., Daily, G.C., Goldstein, J., Kareiva, P.M., Lonsdorf, E., Naidoo, R., Ricketts, T.H. and Shaw, M., 2009: Modeling multiple ecosystem services, biodiversity conservation, commodity production, and tradeoffs at landscape scales. *Frontiers in Ecology and the Environment*, **7**(1): 4-11.
- Nelson, E.J., Kareiva, P., Ruckelshaus, M., Arkema, K., Geller, G., Girvetz, E., Goodrich, D., Matzek, V., Pinsky, M., Reid, W., Saunders, M., Semmens, D. and Tallis, H., 2013: Climate change's impact on key ecosystem services and the human well-being they support in the US. *Frontiers in Ecology and the Environment*, **11**(9): 483-893.
- Norton, L., Elliott, J.A., Maberly, S.C. and May, L., 2012: Using models to bridge the gap between land use and algal blooms: An example from the Loweswater catchment, UK. *Environmental Modelling & Software*, **36**: 64-75.
- O' Farrell, P.J., Anderson, P.M.L., Le Maitre, D.C. and Holmes, P.M., 2012: Insights and Opportunities Offered by a Rapid Ecosystem Service Assessment in Promoting a Conservation Agenda in an Urban Biodiversity Hotspot. *Ecology and Society*, **17**(3).
- OECD, Better Life Index. accessed on May 2015 from: <http://www.oecdbetterlifeindex.org>,
- Olander, L. and Maltby, L., 2014: Mainstreaming ecosystem services into decision making. *Frontiers in Ecology and the Environment*, **12**(10): 539-539.
- Oteros-Rozas, E., Martín-López, B., Daw, T., Bohensky, E., Butler, J., Hill, R., Martín-Ortega, J., Quinlan, A., Ravera, F., Ruiz-Mallén, I., Thyresson, M., Mistry, J., Palomo, I., Peterson, G., Plieninger, T., Waylen, K., Beach, D., Bohnet, I., Hamann, M., Hanspach, J., Hubacek, K., Lavorel, S. and Vilarly, S., 2015: Participatory scenario-planning in place-based social-ecological research: insights and experiences from 23 case studies. *Ecology and Society*, **In Press**.
- Palomo, I., Martín-López, B., López-Santiago, C. and Montes, C., 2011: Participatory scenario planning for protected areas management under the ecosystem services framework: the Doñana social-ecological system in southwestern Spain. *Ecology and Society*, **16**(1): 23.
- Palomo, I., Martín-López, B., Potschin, M., Haines-Young, R. and Montes, C., 2013: National Parks, buffer zones and surrounding lands: Mapping ecosystem service flows. *Ecosystem Services*, **4**: 104-116.
- Palomo, I., Montes, C., Martín-López, B., González, J.A., García-Llorente, M., Alcorlo, P. and Mora, M.R.G., 2014: Incorporating the Social–Ecological Approach in Protected Areas in the Anthropocene. *Bioscience*.
- Paul, K.I., Reeson, A., Polglase, P., Crossman, N., Freudenberger, D. and Hawkins, C., 2013: Economic and employment implications of a carbon market for integrated farm forestry and biodiverse environmental plantings. *Land Use Policy*, **30**(1): 496-506.

- Pauly, D., Christensen, V. and Walters, C., 2000: Ecopath, Ecosim, and Ecospace as tools for evaluating ecosystem impact of fisheries. *ICES Journal of Marine Science*, **57**: 697-706.
- Peh, K.S.H., Balmford, A.P., Bradbury, R.B., Brown, C., Butchart, S.H.M., Hughes, F.M.R., Stattersfield, A.J., Thomas, D.H.L., Walpole, M. and Birch, J.C., 2014: Toolkit for Ecosystem Service Site-based Assessment (TESSA). Version 1.2. Cambridge, UK.
- Peterson, G., 2000: Political ecology and ecological resilience: An integration of human and ecological dynamics. *Ecological Economics*, **35**(3): 323-336.
- Peterson, G.D., Cumming, G.S. and Carpenter, S.R., 2003: Scenario Planning: a Tool for Conservation in an Uncertain World. *Conservation Biology*, **17**(2): 358-366.
- Raudsepp-Hearne, C., Peterson, G.D. and Bennett, E.M., 2010a: Ecosystem service bundles for analyzing tradeoffs in diverse landscapes. *Proceedings of The National Academy of Sciences*, **107**: 5242--5247.
- Raudsepp-Hearne, C., Peterson, G.D., Tengö, M., Bennett, E.M., Holland, T., Benessaiah, K., MacDonald, G.K. and Pfeifer, L., 2010b: Untangling the environmentalist's paradox: why is human well-being increasing as ecosystem services degrade? *Bioscience*, **60**(8): 576-589.
- Renaud, F.G., Sudmeier-Rieux, K. and Estrella, M., 2013: *The Role of Ecosystems in Disaster Risk Reduction*. Tokyo, United Nations University Press.
- Reyers, B., Biggs, R., Cumming, G.S., Elmqvist, T., Hejnowicz, A.P. and Polasky, S., 2013: Getting the measure of ecosystem services: a social-ecological approach. *Frontiers in Ecology and the Environment*, **11**(5): 268-273.
- Rosenthal, A., Verutes, G., McKenzie, E., Arkema, K.K., Bhagabati, N., Bremer, L.L., Olwero, N. and Vogl, A.L., 2014: Process matters: a framework for conducting decision-relevant assessments of ecosystem services. *International Journal of Biodiversity Science, Ecosystem Services & Management*, **11**(3): 190-204.
- Ruckelshaus, M., McKenzie, E., Tallis, H., Guerry, A., Daily, G., Kareiva, P., Polasky, S., Ricketts, T., Bhagabati, N., Wood, S.A. and Bernhardt, J., 2015: Notes from the field: Lessons learned from using ecosystem service approaches to inform real-world decisions. *Ecological Economics*, **115**: 11-21.
- sCBD and WHO, 2015: Connecting Global Priorities: Biodiversity and Human Health. Summary of the State of Knowledge Review. Secretariat of the Convention on Biological Diversity and the World Health Organization, Montreal, Canada.
- Schulp, C.J.E., Thuiller, W. and Verburg, P.H., 2014a: Wild food in Europe: A synthesis of knowledge and data of terrestrial wild food as an ecosystem service. *Ecological Economics*, **105**: 292-305.
- Schulp, C.J.E., Alkemade, R., Klein Goldewijk, K. and Petz, K., 2012: Mapping ecosystem functions and services in Eastern Europe using global-scale data sets. *International Journal of Biodiversity Science, Ecosystem Services & Management*, **8**(1-2): 156-168.
- Schulp, C.J.E., Burkhard, B., Maes, J., Van Vliet, J. and Verburg, P.H., 2014b: Uncertainties in Ecosystem Service Maps: A Comparison on the European Scale. *PLoS ONE*, **9**(10): e109643.
- Sherrouse, B.C., Clement, J.M. and Semmens, D.J., 2011: A GIS application for assessing, mapping, and quantifying the social values of ecosystem services. *Applied Geography*, **31**(2): 748-760.
- Sherrouse, B.C., Semmens, D.J. and Clement, J.M., 2014: An application of Social Values for Ecosystem Services (SolVES) to three national forests in Colorado and Wyoming. *Ecological Indicators*, **36**: 68-79.
- Smulders, S., 2008: Green national accounting. In *The New Palgrave Dictionary of Economics*, Durlauf, S.N. and Blume, L.E., eds., Basingstoke, Palgrave Macmillan.
- Stehfest, E., Van Vuuren, D., Kram, T., Bouwman, L., Alkemade, R., Bakkenes, M., Biemans, H., Bouwman, A., Den Elzen, M., Janse, J., Lucas, P., Van Minnen, J., Müller, C. and Prins, A.G., 2014: *Integrated Assessment of Global Environmental Change with IMAGE 3.0. Model description and policy applications*. The Hague, PBL Netherlands Environmental Assessment Agency.
- Syrbe, R.-U. and Walz, U., 2012: Spatial indicators for the assessment of ecosystem services: Providing, benefiting and connecting areas and landscape metrics. *Ecological Indicators*, **21**: 80-88.
- Tengö, M., Brondizio, E., Elmqvist, T., Malmer, P. and Spierenburg, M., 2014: Connecting Diverse Knowledge Systems for Enhanced Ecosystem Governance: The Multiple Evidence Base Approach. *AMBIO*, **43**(5): 579-591.

- Thompson, J.R., Wiek, A., Swanson, F.J., Carpenter, S.R., Hollingsworth, T., Spies, T.A. and Foster, D.R., 2012: Scenario Studies as a Synthetic and Integrative Research Activity for Long-Term Ecological Research. *Bioscience*, **62**(4): 367-376.
- Townsend, M., Henderson-Wilson, C., Warner, E. and Weiss, L., 2015: *Healthy Parks Healthy People: the state of the evidence 2015*. Melbourne, Deakin University.
- U.S. EPA, 2015: *National Ecosystem Services Classification System (NESCO): Framework Design and Policy Application*. EPA-800-R-15-002. United States Environmental Protection Agency. Washington, DC.
- UN, EU, FAO, OECD and WBG, 2014: System of Environmental-Economic Accounting 2012—Experimental Ecosystem Accounting. United Nations, European Union, Food and Agriculture Organization of the United Nations, Organisation for Economic Co-operation and Development, World Bank Group, ST/ESA/STAT/Ser.F/112, New York.
- UNDP, 2014: *Sustaining human progress: reducing vulnerabilities and building resilience*. New York, NY, United Nations Development Programme.
- UNU-IHDP and UNEP, 2014: *Inclusive Wealth Report 2012. Measuring progress toward sustainability*. Cambridge, Cambridge University Press.
- van Vliet, M., Kok, K. and Veldkamp, T., 2010: Linking stakeholders and modellers in scenario studies: The use of Fuzzy Cognitive Maps as a communication and learning tool. *Futures*, **42**(1): 1-14.
- Vervoort, J.M., Kok, K., Beers, P.J., Van Lammeren, R. and Janssen, R., 2012: Combining analytic and experiential communication in participatory scenario development. *Landscape and Urban Planning*, **107**(3): 203-213.
- Villa, F., Bagstad, K.J., Voigt, B., Johnson, G.W., Portela, R., Honzák, M. and Batker, D., 2014: A Methodology for Adaptable and Robust Ecosystem Services Assessment. *PLoS ONE*, **9**(3): e91001.
- Walters, C.J., 1986: *Adaptive management of renewable resources*. New York, New York., Collier Macmillan.
- Walters, C.J., Christensen, V. and Pauly, D., 1997: Structuring dynamic models of exploited ecosystems from trophic mass-balance assessments. *Reviews in Fish Biology and Fisheries*, **7**: 139-172.
- Wheeler, B., Lovell, R., Higgins, S., White, M., Alcock, I., Osborne, N., Husk, K., Sabel, C. and Depledge, M., 2015: Beyond greenspace: an ecological study of population general health and indicators of natural environment type and quality. *International Journal of Health Geographics*, **14**(1): 17-17.
- Whitmee, S., Haines, A., Beyrer, C., Boltz, F., Capon, A.G., de Souza Dias, B.F., Ezeh, A., Frumkin, H., Gong, P., Head, P., Horton, R., Mace, G.M., Marten, R., Myers, S.S., Nishtar, S., Osofsky, S.A., Pattanayak, S.K., Pongsiri, M.J., Romanelli, C., Soucat, A., Vega, J. and Yach, D., 2013: Safeguarding human health in the Anthropocene epoch: report of The Rockefeller Foundation-Lancet Commission on planetary health. *The Lancet*, **386**(10007): 1973-2028.
- Willemsen, L., Hein, L. and Verburg, P.H., 2010: Evaluating the impact of regional development policies on future landscape services. *Ecological Economics*, **69**(11): 2244-2254.
- Willemsen, L., Veldkamp, A., Verburg, P.H., Hein, L. and Leemans, R., 2012: A multi-scale modelling approach for analysing landscape service dynamics. *Journal of Environmental Management*, **100**: 86-95.
- Wong, C.P., Jiang, B., Kinzig, A.P., Lee, K.N. and Ouyang, Z., 2014: Linking ecosystem characteristics to final ecosystem services for public policy. *Ecology Letters*, **18**(1): 108-118.
- World Bank, 2011: *The Changing Wealth of Nations: Measuring Sustainable Development in the New Millennium*. Washington DC, The World Bank.

Chapter 6 Linking and harmonizing scenarios and models across scales and domains

Coordinating Lead Authors:

William W. L. Cheung (China), Carlo Rondinini (Italy)

Lead Authors:

Ram Avtar (India), Marjan van den Belt (New Zealand), Thomas Hickler (Germany), Jean Paul Metzger (Brazil), Jörn P. W. Scharlemann (United Kingdom), Ximena Velez-Liendo (Bolivia), Tianxiang Yue (China)

Contributing Authors:

Yi-Fu Wang (China), Na Zhao (China)

Review Editor:

Stoyan Nedkov (Bulgaria)

Purpose of this chapter: Critically reviews approaches to linking and harmonizing the various types of scenarios and models described in Chapters 3, 4 and 5 across scales, domains and elements, thereby better serving the diverse needs of policy and decision-making (as covered in Chapter 2); and proposes ways in which IPBES might best achieve such integration in its own assessments.

Target audience: Aimed mostly at a more technical audience – i.e. scientists and practitioners wanting to identify appropriate approaches to linking and harmonizing scenarios and models for different applications.

Key findings

Linking models and scenarios can be used to aid understanding of the positive and negative impacts of an action across interconnected scales (time, space, social organization) and elements (biodiversity, ecosystem services, human well-being) (Sections 6.1, 6.5). However, linking models and scenarios is not appropriate in every decision context, particularly when error propagation increases uncertainty to an unacceptable level. Existing families of approaches include one-way (information is passed in one direction between two or more models), two-way (information is passed in both directions between models allowing for feedbacks), loose (meaning that model output can be computed separately) and tight (integrated, requiring simultaneous processing of multiple models) coupling (Section 6.2). One-way loose coupling (quantitative and/or qualitative) is used most frequently, because it is relatively straightforward and often meets the desired objectives. Two-way coupling is more complex, but needed and beneficial in some situations to explore and capture feedbacks.

Harmonization enables comparisons across models and scenarios, which is a necessary step to understand the uncertainty around possible outcomes (Section 6.4). It also involves upscaling and downscaling models and scenarios in organization, space and time, as well as model benchmarking. Up- and down-scaling along a social organizational scale requires awareness of humanly imposed boundaries and conventions (Section 6.4.1). Ecosystem services approach can be considered an organizing principle for harmonization along an organizational scale (Section 6.4.1.1). Spatial downscaling provides information for local-scale policy making when high resolution information is not available. Statistical downscaling is most often used; however, dynamic downscaling that is based on mechanistic models may be more appropriate than statistical downscaling in systems where the relationship between coarse scale and fine scale dynamics are complex and non-linear, or observational data are insufficient (Section 6.4.1.2). In the process of upscaling, quantitative approaches to preserve the quality of the original information should be applied whenever possible; otherwise it can contribute to scaling uncertainties (Section 6.5.2). Upscaling and downscaling methods across temporal scales are in principle similar to those for spatial scale (Section 6.4.1.3).

Multi-scale scenarios that link global and regional-scale scenarios have been useful for informing environmental assessments that need to consider drivers at different scales (Section 6.4). Approaches for developing multi-scale scenarios include using global-scale scenarios as boundary conditions for regional-scale scenarios, translating global-scale storylines into regional storylines, using standardised scenario families to independently develop scenarios across scales, and the direct use of global scenarios for regional policy contexts. However, there are few approaches and examples for up-scaling regional scenarios for global assessments (Section 6.4.2).

Multi-model benchmarking activity with biodiversity models at the species level or ecosystem service models is not available. Benchmarking is the process of systematically comparing sets of model predictions against measured data in order to evaluate model performance. It should also help identify processes that may be poorly represented in models (Section 6.4.3).

Uncertainties originated from different biodiversity and ecosystem services models that are linked across spatial and temporal scales, elements and domains may potentially propagate through the chains of models, affecting the ultimate envelope of uncertainty. Available options to address errors associated with linking models include not linking the models, limit the extent of model linkages and exploring the envelope of uncertainty resulting from model linkages. When system processes interact across scales, resulting in nonlinear dynamics, harmonizing of models and their outputs across these scales is more prompt to scaling error. In such cases, the use of multiple scale models perform better than single scale models (Section 6.5).

Key recommendations

The Intergovernmental Platform on Biodiversity and Ecosystem Services (IPBES) Task Force on Capacity-Building could help to foster the development of communities of multi-disciplinary researchers and practitioners to harmonize and link across models, scales, domains and elements (Section 6.1). This would encourage shared learning from experience gained from different approaches employed in different parts of the world – e.g., across different regions or countries.

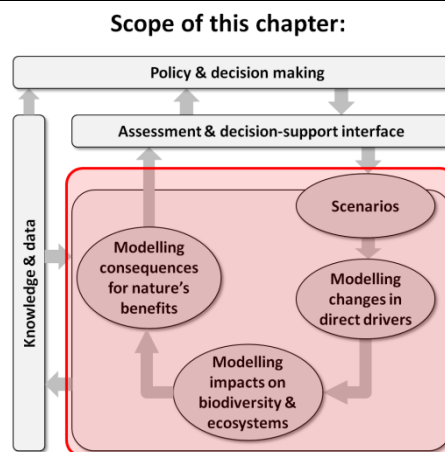

The IPBES Global and Regional Assessments would benefit greatly by not limiting their work to a particular scale, but rather use multi-scale scenarios (Section 6.4) that are coupled both loosely and tightly (Section 6.1). The loose-coupling approach is particularly suitable for framing stakeholder issues, while the latter also allows consideration of feedbacks among scales, elements and domains and promote more detailed system understanding.

The IPBES Task Force on Knowledge, Information and Data could work with the scientific community to define a set of standard conditions and components for ‘IPBES compatible’ model and scenario components that share a common ground (Section 6.4, and see also Chapter 5 and 8). This could be similar to the approach that has successfully been implemented through coordinated efforts between the Intergovernmental Panel on Climate Change (IPCC) and the scientific community.

The IPBES Task Force on Knowledge and Data could play an important role in encouraging the incorporation in Integrated Assessment Models (IAMs) of ecological processes (e.g., population dynamics or biogeography of groups of animals) (Section 6.3). This would allow these classes of models to address a broader range of questions related to biodiversity and ecosystem services.

The IPBES Global and Regional Assessments should consider exploring the use of existing scenario archetypes (families) to link and harmonize scenarios that best respond to their questions. Common scenario families include economic optimism, reformed markets, global sustainable development, regional competition, regional sustainable development and business-as-usual (Section 6.4).

To improve linkages and harmonization of models and scenarios for assessing ecosystem services, human well-being and policy options, the IPBES Task Force on Knowledge, Information and Data could facilitate the development an open source data infrastructure to share multi-disciplinary data, toolkits and tested methods, and promote the use of common terminology (Section 6.4). This would allow informed linking and harmonization of scenarios and models, as well as model benchmarking.

6.1 Importance of linking and harmonizing models and scenarios

6.1.1 Point-of-departure

Models and scenarios are important tools to understand and communicate the effects of natural and human drivers on biodiversity and ecosystem services (Chapter 3, 4 and 5). The temporal, spatial, and social organizational scales that a single modelling or scenario assessment focuses on are generally specific to particular policy contexts (Chapter 2).

However, biodiversity, ecosystem services and their drivers are interconnected, and can span multiple spatial and temporal scales, domains and elements of the IPBES framework (see Chapter 1 and Glossary). Thus, linking models and linking scenarios and harmonizing across different scales, domains and elements are important steps in advancing our understanding of how we can sustain human well-being while ensuring conservation of biodiversity (Steffen et al., 2015; Mace et al., 2012; Dearing et al., 2014).

Here, the concept of ‘domain’ include the dimension of space, time, disciplines and knowledge.

Overall, this chapter aims to: a) summarize existing approaches and initiatives that link and harmonize models and scenarios across scales, domains and elements; b) discuss relevance to policy-making; c) identify knowledge gaps; d) propose possible ways for IPBES to undertake multi-scale/domain/element linkages and harmonization to assess biodiversity and ecosystem services. This chapter builds upon Chapters 2 to 5 to assess the availability of tools and methods for linking and harmonizing scenarios and models of drivers of biodiversity (Chapter 3), impacts of these drivers on biodiversity, ecosystem functions (Chapter 4) and benefits to people (Chapter 5) in order to inform policy-making at specific spatial and temporal scales (Chapter 2). Models for biodiversity and ecosystem services can be run at a wide range of spatial, temporal and organizational scales depending on the elements, domains and processes that they represent (Figure 6.1, see Section 6.2). Here we focus on both short (10 – 15 years) and long (multi-decadal) temporal scales, and on national, regional, and global (*sensu* IPBES) spatial scales. We present case studies selected across a variety of elements and applications to showcase approaches that tackle complex issues.

6.1.2 Linking and harmonizing models and scenarios: why and why not

Linking models and scenarios can be used to aid understanding of the (positive and negative) impacts of an action across interconnected elements, by revealing the interactions and feedbacks across multiple elements and domains of social, economic and natural systems (Carpenter et al., 2006) .

Decision makers, from individuals to global institutions, are unlikely to have knowledge about the entirety of impacts of their chosen actions within an element and across multiple, interconnected elements (Chapter 2). An action may impact individual elements in different and often unexpected ways across spatial and temporal scales, as well as potentially affect multiple elements. For example, damming a river impacts fish up- and down-stream of the dam (migration barrier; *spatial impacts*), immediately and in the longer term (altered water flow, sediment accumulation in reservoir; *temporal impacts*), and impacts fish, aquatic and terrestrial plants, and people (*multiple elements/domains*).

For some decision contexts, multiple models and scenarios exist, or could be developed, that provide different information to decision makers (Chapter 2). Models or scenarios may differ because they (a) were developed to address subtly different questions for different audiences (e.g., composition and function of biodiversity, temperature and precipitation for climate) and therefore produce different outputs (e.g., carbon ecosystem service models may output carbon stocks or carbon sequestration); (b) use different input data (e.g., different biophysical layers for species distribution modelling); (c) represent different components/elements within the model/scenario (e.g., biodiversity models may incorporate metabolism, reproduction, growth, dispersal, mortality); (d) use different methodologies or techniques (e.g., from correlative to process-based models, Chapter 4); or (e) cover different spatial and/or temporal scales.

To bring models or scenarios together and compare them, they need to be made compatible or consistent with one another; this process is referred to as ‘harmonization’.

Harmonization is related to the concept of interoperability, or the ability of different information technology components, systems, and software applications to communicate and exchange data accurately, effectively, and consistently, and to use the information that has been exchanged (Heubusch, 2006; Matott et al., 2008; Laniak et al., 2013). Models and scenarios can be harmonized in multiple ways, by using: standardised inputs (e.g., all Integrated Assessment Models used in IPCC Fifth Assessment Report use the same harmonized land use data, Hurtt et al. (2011), agreed output metrics, evaluation or benchmarking against common observational data sets (e.g., Global Circulation Models to be included in IPCC need to be able to hind cast historic temperature trends, derived from multiple sources), or specifying the key components and elements that need to be represented in the model/scenario.

Linking multiple models and scenarios is not appropriate in every decision context.

First, each model and scenario comes with its own assumptions. When these assumptions are incompatible, linking the models/scenarios produces an uninformative output (Laniak et al., 2013). Second, the causality of links across elements is sometimes poorly understood. In such situations, the output of linked models scenarios would become a poor representation of phenomena. Third, output-input chains and feedbacks of models are often complex, difficult to debug and potentially result in error propagation and uncertainty. These become unhelpful for decision-making when error propagation increases uncertainty to an unacceptable level (Dunford et al., 2014; see 6.5). Voinov and Shugart (2013) caution that in some cases the software engineering approach of mechanically connecting models as software can result in conceptually ambiguous products or ‘integronsters’, which seem to be technically correct but make little sense as realistic system models and decision support tools. In addition to data integration that checks the consistency with the models specifications (units and temporal-spatial scales) and assumptions when passing data between models, semantic integration of concepts and assumptions is also important in linking models. Given the potential complexity in linking models and scenarios, the amount of linkage among models/scenarios needs to be tailored to the decision at stake (Chapter 2).

Scenarios and models may differ because they do not share the same values, or the same worldviews (i.e., decision uncertainty), and it may be important to present these differences clearly. Likewise, models may differ in the drivers and processes included. Without clear understanding of these drivers and processes, it is not beneficial to harmonize the models and their outputs.

Standardising inputs and output metrics and components included in models likely reduces the uncertainty around estimates (e.g., by using standardised model inputs or by removing outliers), however this usually results in models/scenarios that give more similar outputs which may be more precise, but not necessarily accurate and therefore less policy relevant. By *a priori* standardising inputs and components as well as ensuring validation against a standard dataset, models/scenarios that are projecting low frequency-high impact events may be excluded (Levin, 2003) (e.g., the 2008 financial crisis or abrupt climate change).

6.2 Approaches for linking and harmonizing models and scenarios

Models or scenarios developed for different spatial and temporal scales, domains and for different elements (i.e. the elements of the IPBES framework, see also Figure 6.1) can be linked or harmonized using several approaches (Table 6.1). Linking works by feeding outputs of one model as input to another model, which can be done iteratively (two-way or tight coupling) or off-line (one-way or loose coupling). Models and scenarios can also be linked qualitatively (e.g., through narratives or description of storylines). Models and scenarios describing different elements may also be combined quantitatively or qualitatively to provide a more holistic assessment, as done by Integrated Assessment Models (IAMs), and more generally, Integrated Environmental Modelling approaches (Laniak et al., 2013).

Linking works by feeding outputs of one model as input to another model, which can be done iteratively (two-way or tight coupling) or off-line (one-way or loose coupling). Models and scenarios can also be linked qualitatively (e.g., through narratives or description of storylines).

Integrated Environmental Modelling broadly refers to modelling approaches that represent holistic system-level thinking by using quantitative and participatory methods for defining, selecting, integrating, and processing the combination of environmental, social and economic information needed to inform decisions and policies related to the environment (Laniak et al., 2013). Note that frequently links are being made across spatial and temporal scales, and elements may act on one another at different scales (also see IPBES/3/INF/4, <http://ipbes.net/>, Chapter 2). For example, historic global climate data may be used as input for modelling the current distribution of species at national scale, which then are used to estimate a provisioning ecosystem service (blue arrows in Figure 6.1).

Table 6.1

Summary of different approaches to linking and harmonizing models and scenarios.

	Approaches	Model	Scenario
Linking	Output-input, one-way coupling (section 6.3.1)	x	
	Output-input, two-way coupling (section 6.3.1)	x	
	Combining outputs qualitatively (section 6.3.2)	x	x
Harmonizing	Standardization of metrics (input and/or output) through a) classification schemes and taxonomies; b) converting across dimensions, domains and organizational levels; c) scaling in time and space (sections 6.4.1-2)	x	x
	Benchmarking (section 6.4.3)	x	

Harmonization of models and scenarios occurs across domains and spatial and temporal scales *within* an element.

In particular, harmonization involves the standardization of metrics (e.g., output metrics of models, conditions for scenarios i.e. CO₂ concentration, agricultural production) and input data (e.g., land use, temperature) or both.

For nominal variables, this can be achieved through the adoption of standard classification schemes (e.g., the unified classification of species threats and conservation actions, Salafsky et al. 2008).

Harmonization often involves upscaling and downscaling models and scenarios in space and time, as well as model benchmarking.

Benchmarking is not applicable to scenarios because these are by definition alternative to each other. Harmonized models and scenarios and their outputs facilitate model linking, error detection and uncertainty estimation and ultimately decision making.

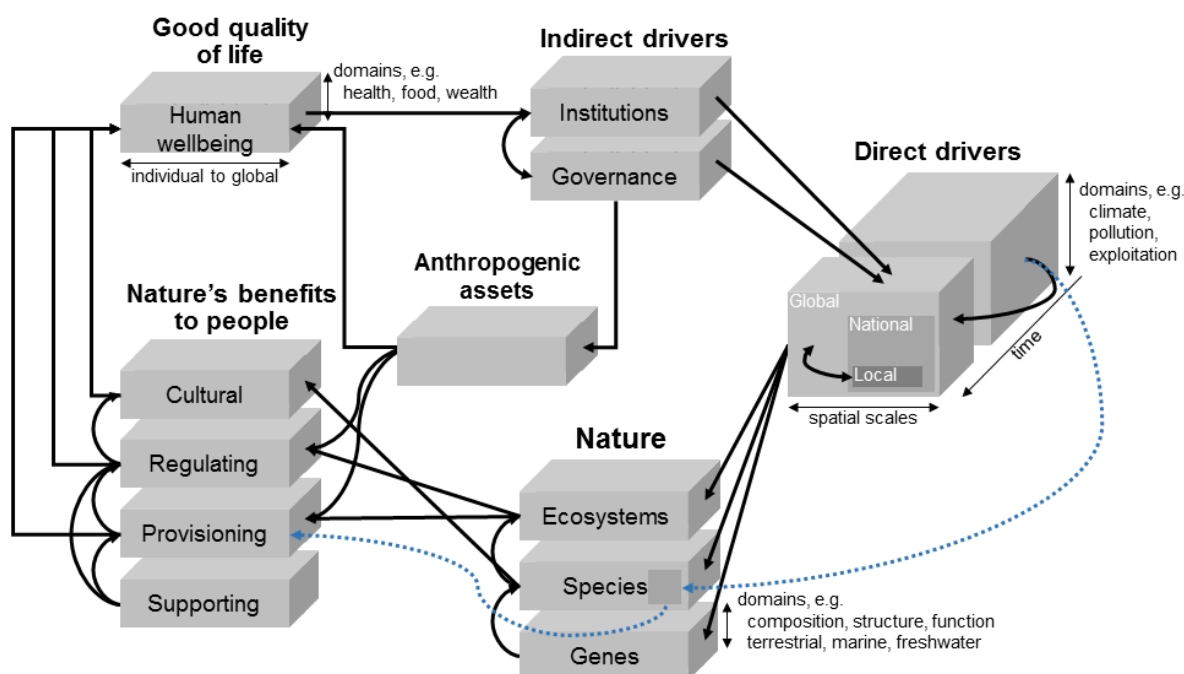

Figure 6.1: Linking models among the six elements of the IPBES conceptual framework (straight arrows) and within domains (vertical axis), spatial (horizontal) and temporal (Z dimension) scales of each element (curved arrows). Each element has multiple dimensions (examples shown) including temporal and spatial scales, and disciplinary and organizational domains. Blue arrow explained in text.

6.3 Linking models and scenarios of biodiversity and ecosystem services

6.3.1 Model coupling through input-output

Models representing different components of the social-ecological system are linked through either one-way (off-line) or two-way coupling (which allows feedback). In both cases, outputs from one model feed into another model as inputs. For example, in modelling the effects of changes in ocean conditions (temperature, primary productivity, oxygen level and acidity, and the resulting species range shifts) on marine ecosystems in the Northeast Pacific coasts, Ainsworth et al. (2011) took simulated changes in ocean conditions from a coupled ocean-atmospheric earth system model and projected range shifts from species distribution models as inputs (forcing factors) in trophodynamic food web models to simulate the effects of multiple CO₂-related drivers on marine ecosystems and fisheries yields. Visconti et al. (2015) used models of climate and land use change based on scenarios of socio-economic development as an input to species distribution models that projected distributions into the future, and assembled these projections into policy-relevant indicators of biodiversity change (Box 6.1). Two-way coupling includes feedbacks of inputs-outputs between models. For example, a marine ecosystem model, Atlantis (Fulton et al., 2011), links model components describing ocean biogeochemistry, lower-trophic level ecosystem, upper-trophic level ecosystem and human activities (with a focus on fishing) in which outputs from the components mutually affect one another directly or indirectly over space and time.

Box 6.1: Using scenarios of global change to project species distributions and biodiversity trends into the future

To project trends of ca. 400 species of terrestrial large mammals under scenarios of global change, Visconti et al. (2015) used multiple models (climate models, an integrated assessment model and species distribution models) linked using the output-input method with one-way loose coupling.

The impact of climate change on species' geographic range was quantified by fitting bioclimatic envelope models to the present-day species' distributions, and projecting these under future climate associated with two scenarios of socio-economic development until 2050. The two scenarios, developed for the Rio+20 conference held in Rio in 2002 represent business-as-usual production and consumption patterns and rates, or reduced consumption (PBL, 2012). For each socio-economic scenario, three species responses to climate change were tested: 1) species cannot disperse into new climatically suitable areas; 2) species can expand their distributions each generation by a median dispersal distance estimated using statistical models; or 3). Species adapt locally (their geographic ranges are not affected by climate change). Projected species ranges were further assessed for compatibility with species' fine-scale ecological requirements with habitat suitability models (Rondinini et al., 2011; Visconti et al., 2011) based on species' land cover and altitudinal preferences and sensitivity to human disturbance. These models were applied to projected land-use maps from the Integrated Model to Assess the Global Environment (IMAGE) (Bouwman et al., 2006) under each scenario, to quantify for each species the extent of suitable habitat. The distribution projected under each climate change scenario was taken as the extent of occurrence. The extent of suitable habitat was treated as the maximum potential value of area of occupancy. The number of mature individuals of a species was estimated by multiplying the area of occupancy by population density from observed and modelled data. These parameters were applied to Red List criteria to evaluate each species' Red List category for each year under each scenario, from which the overall Red List Index (RLI) was calculated following Butchart et al. (2007) (Figure Box 6.1). The uncertainty around the proportion of mature individuals and proportion of suitable habitat occupied (area of occupancy/extent of suitable habitat) was incorporated into RLI projections by randomly sampling these parameters from a distribution with intervals gathered from the literature and performing a Monte Carlo simulation. Estimates of mature individuals for each species and each year were used to generate the Living Planet Index (LPI) for each scenario following Collen et al. (2009). The methodology was validated through hind-casting species distributions and biodiversity indicators from 1970.

Testing these on terrestrial carnivore and ungulate species, Visconti and colleagues found that both indicators decline steadily, and by 2050, under a business-as-usual scenario, the LPI declines by 18-35% while extinction risk increases for 8-23% of the species, depending on assumptions about species responses to climate change. Business-as-usual will therefore fail Convention on Biological Diversity (CBD) target 12 of improving the conservation status of known threatened species. An alternative sustainable development scenario reduces both extinction risk and population losses compared with Business-as-usual and could lead to population increases.

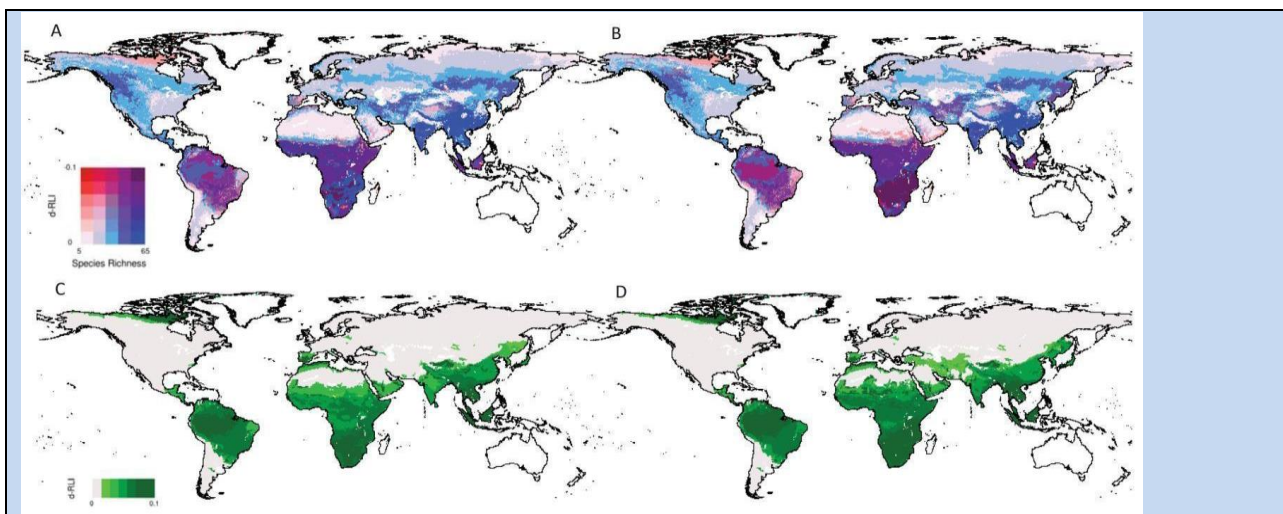

Figure Box 6.1 Spatial patterns of trends in Red List Index. (A,B) Bivariate plot showing spatial pattern in species richness and trends in the Red List Index (d-RLI) between 2010 and 2050 under the business-as-usual scenario, with land use and climate change and assuming maximum dispersal (A) and no dispersal (B). (C-D) Relative improvements in d-RLI for the reduced impact scenario relative to business-as-usual for year 2050 under maximum dispersal (C) and no dispersal (D). Areas in white contain fewer than 5 species per grid cell modelled in 2010.

The choice of coupling methods depends on the dynamics of the modelled systems and the objectives of the models.

One-way coupling is simpler to implement than dynamic two-way coupling, because the models can be run sequentially.

The responses of the modelled system are also more predictable, because feedbacks are not allowed (e.g., predicting changes in fish distribution and production driven by earth system model outputs vs. tightly-coupled system dynamic models, where changes in fish stocks feedback to changes in ocean biogeochemistry and climate). On the other hand, non-linear system dynamics and feedback between model domains cannot be directly revealed with models that are coupled one-way.

Two-way coupling is more realistic for understanding social-ecological systems where feedbacks and resulting non-linear responses are common among domains and elements.

However, it is technically more difficult, particularly if components operate at different temporal and spatial scales. The model responses are also less predictable and may result in large internal variability.

Most examples of impact models of relevance for IPBES concern one-way coupling between models (Table 6.2). Two-way coupling or full socio-ecological systems modelling is not common. The rare examples include Integrated Assessment Models (IAMs) (e.g., IMAGE 3.0, Box 6.2), which only represent very general system characteristics and are of limited use for regional or local policy making or stakeholders.

Integrated assessment models combine components (sub-models) representing the future development of human societies, including major sectors such as energy use, industrial development and land use, which are important for making projections about the future of human and natural ecosystems (Harfoot et al., 2014). Currently, the main applications of IAMs concern modelling climate change and effects of climate mitigation. In most IAMs, their sub-models, including both natural and human subsystems, are linked although dynamic linkages are not commonly represented in most IAMs (Harfoot et al., 2014). An example of natural systems sub-models in an IAM is the linkage between hydrological models providing inputs regarding water and nutrient supply into terrestrial vegetation models. For human systems sub-models, it includes, for example, component representing the energy sectors that capture the demand and supply of energy as links to industrial development, population demand and commodity prices. There are also components that link natural-human systems such as food production, linking vegetation and land-use with societal demand, energy sources (particularly from bio-energy crops) and commodity prices.

Table 6.2

Impact model types of special relevance for IPBES (adopted from Chapter 4, Section 4.3.1, sub-section given in parentheses) and examples for using those impact model types for ecosystem service scenarios. The ecosystem service categories have been adopted from Crossman et al. (2013).

Impact model types of special relevance for IPBES	Examples of model applications to develop ecosystem services scenario	Main ecosystem services potentially addressed
Individual level models and evolutionary adaptation (4.3.1.1)	-	Provisioning Cultural and Amenity
Population models (4.3.1.2)	-	Provisioning Cultural and Amenity
Species distribution models (4.3.1.2)	Exploited marine species (Cheung et al., 2010 , forestry revenues (Hanewinkel et al., 2012)	Provisioning Cultural and Amenity
Community-level models (4.3.1.3)	-	Provisioning Cultural and Amenity
Dynamic Global Vegetation Models (4.3.1.5)	Carbon storage in East Africa (Doherty et al., 2010)	Provisioning Regulation Habitat
Integrated Assessment Models (4.3.1.5)	Variety of ecosystem services, including food provision, water availability, carbon sequestration, flood protection (Stehfest et al., 2014)	Provisioning Regulation Habitat

Box 6.2: Integrated assessment model (IAM) - The IMAGE 3.0 Framework

The IMAGE integrated assessment modelling framework provides an example of the use of IAM approach in linking models for biodiversity and ecosystem services assessment. IMAGE has been developed to understand how global, long-term environmental change and sustainability problems develop over time, driven by human activities, such as economic development and population growth (Figure Box 6.2). Similar to other IAMs, IMAGE can be used to identify problems of global environmental change, and to advise on possible response strategies. Earlier versions of the IMAGE model have been used to support various international assessments, including IPCC assessments, the United Nations Environmental Programme (UNEP)'s Global Environment Outlooks (GEOs), The Organisation for Economic Co-operation and Development (OECD)'s Environmental Outlooks and the Millennium Ecosystem Assessment (MA). Moreover, the model has been extensively used in the scientific literature.

In the IMAGE 3.0 – GLOBIO Framework, of the framework links models of socio-economic drivers, such as climate change, land-use change and pollution, with models assessing impacts on the environment and biodiversity. The results of IMAGE-GLOBIO provided information to policy makers at the international level on current biodiversity status and future trends (Alkemade et al., 2009). Specifically, IMAGE-GLOBIO projected trends in biodiversity under future policy scenarios that involve multiple domains and drivers, including the expected outcome in the absence of additional policies to prevent biodiversity loss. IMAGE-GLOBIO delivers output in terms of Mean Species Abundance (MSA) relative to the natural state of original species), land cover and land use (high resolution land use and land use intensity based on GLC2000 and IMAGE), species richness index (SRI) and Wilderness area. Thus, IMAGE-GLOBIO allows the exploration of policy trade-offs between biodiversity conservation and the effectiveness of achieving goals in other domains.

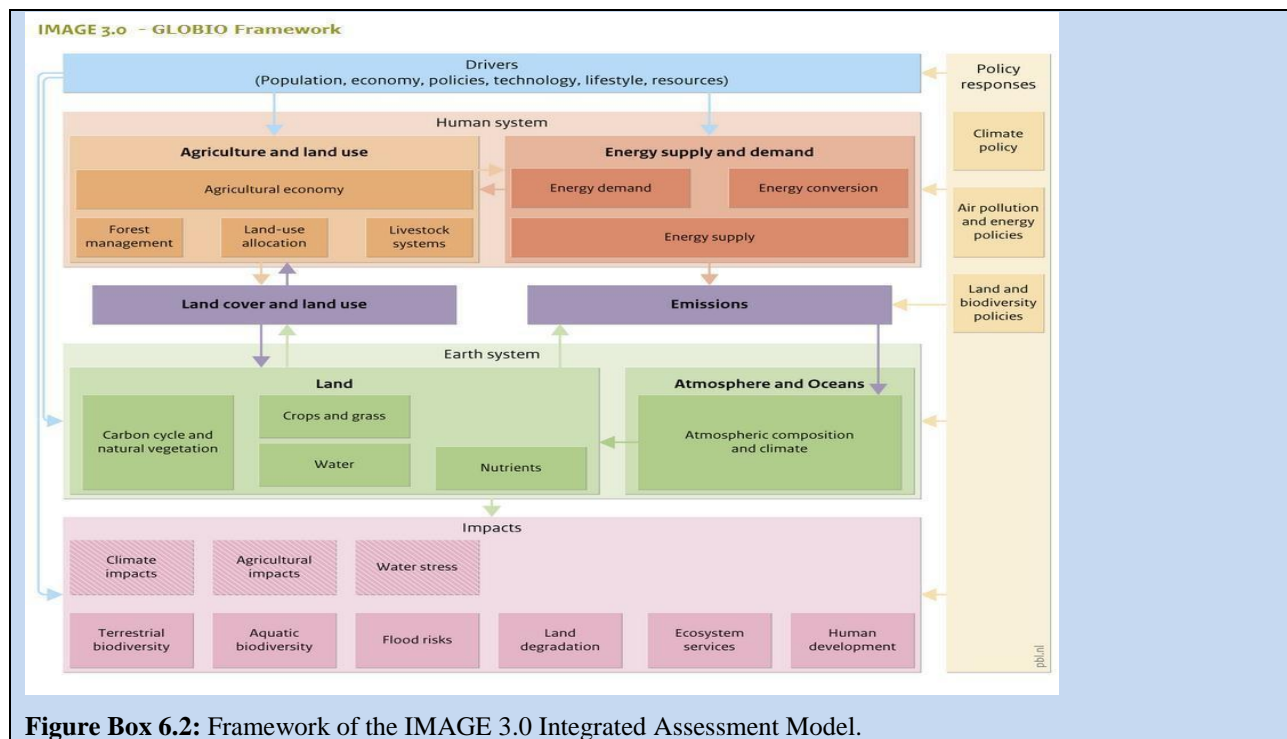

Figure Box 6.2: Framework of the IMAGE 3.0 Integrated Assessment Model.

Using the IAM framework for linking models can address a broader range of questions related to biodiversity, such as trade-offs between climate change mitigation and biodiversity conservation; however, further work is needed to incorporate model components that represent more ecological processes e.g., population dynamics or biogeography of groups of animals (Harfoot et al., 2014).

Currently, the representation of biodiversity in IAMs is largely limited to terrestrial ecosystems (Chapter 4). The complexity of IAMs and substantial resources needed to develop them may also render them less suitable comparing to other simpler methods of linking models.

6.3.2 Combining model and scenario outputs

Outputs from models and scenarios that are complementary in representing different domains and scales can be combined qualitatively so that each provides descriptions, projections or narratives of different axes of the biodiversity and ecosystem services assessment framework.

The projections or narratives generated by models and scenarios representing different domains can be combined to more holistically describe potential changes in social-ecological systems or a subset of the systems. Such linkages would be simple if the models or scenarios are coherent across scales and have the same analytical framework and logic. However, in many cases, models and scenarios may be constructed to be largely independent at different scales or domains, but connected by the same issues they address; or conversely, they may be at the same scales but addressing different issues. An iterative process is generally necessary to incorporate feedbacks and maintain storyline consistency, although feedbacks are seldom considered in this type of linkages. In order for the outputs to be compatible with one another, they should first be harmonized by categorizing them into the same scenario archetype or family based on their drivers, assumptions, scenarios logics and boundary conditions (Zurek and Henrichs, 2007; see 6.4).

6.4 Harmonizing models and scenarios

6.4.1 Harmonizing models across scales

Harmonizing models to assess status and trends, and project future changes in biodiversity and ecosystem services require synthesizing biophysical and socio-economic data and results that are available at different organizational, spatial, temporal scales and domains (Figure 6.2).

Scales can be defined considering two main properties: *grain* and *extent*. Grain refers to the resolution of the data and extent to the size of the dataset. More specifically, the *organizational grain* is the resolution of the social, human or built capital information, the *spatial grain* is the size of the sampling unit, the *temporal grain* is the frequency of data. The extent refers to how large is the human system considered (*organizational extent*), an area (*spatial extent*) or period of time (*temporal extent*). For example, with an Enhanced Thematic Mapper Plus sensor, the spatial grain is 30 meters (for bands 1 to 5), the temporal grain is 16 days (the satellite makes an image of the same place each 16

days), the spatial extent corresponds to a track 183 km wide, and the temporal extent is the duration of the study (for example, few days, one season, several years).

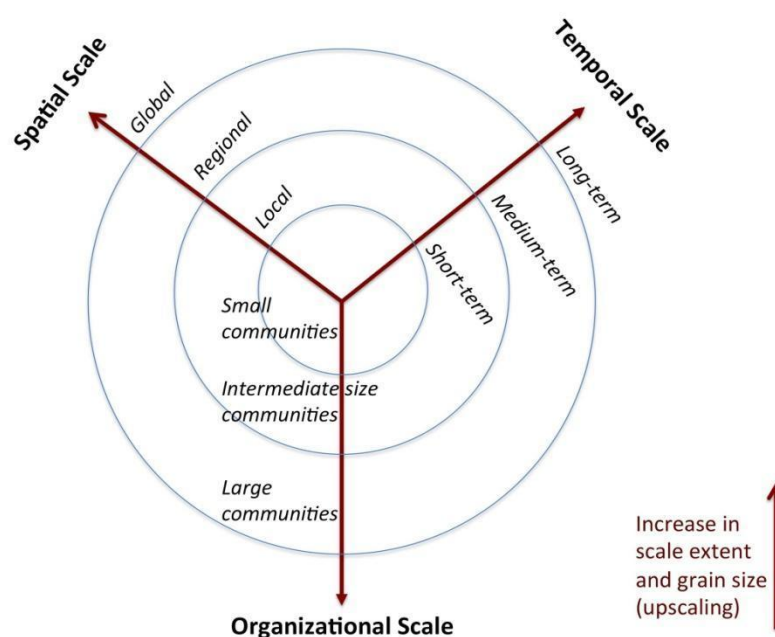

Figure 6.2: Spatial, temporal and organizational scales are usually correlated, thus the consequences of changing the scale of analysis (upscaling or downscaling) in any of these three dimensions need to be carefully considered. Upscaling is related to an increase in scale extent and grain size, while downscaling is the inverse process. Note that the organizational scale, here represented by social organization (e.g., individuals, communities societies), is also relevant to biodiversity (e.g., genes, species, ecosystems) and ecosystem services (e.g., provisioning, regulating, cultural).

Space, time and organizational scales are usually correlated (Figure 6.2; Levin, 1992).

The assessment of large human systems or communities will require data at large spatial and temporal scales (but with low resolution), and inversely data on specific local communities will require more detailed temporal and spatial information, with high resolution. As a consequence of this spatial-temporal interaction, models with coarse spatial resolution usually do not resolve processes that operate at fine temporal scale, and *vice versa*. For example, global scale population dynamic models of fishes do not resolve fine scale behavioural shift of individuals driven by changing local ecological or environmental conditions. There is an optimal scale to understand specific natural dynamics of systems operating at a focal spatial scale (Wiens, 1989) and it is a challenge (for scientists and practitioners) to identify the appropriate scale, e.g., avoiding building too much detailed on coarse-scale models.

Bringing model outputs to the appropriate scale is referred to as scaling, which can be done in two different directions: upscaling information from local, fine-grained resolution to global, coarse-grained resolution, or *vice versa*, downscaling the information.

Upscaling usually leads to an increase in the extent, and decrease in the resolution, while downscaling increases the resolution of the data, while losing the extent (Figure 6.3). Upscaling and downscaling are discussed in detail for organizational, spatial and temporal scales in sections 6.4.1.1-6.4.1.3. In both directions, predictions are associated with errors and uncertainty, which are explored in the next section (Section 6.5).

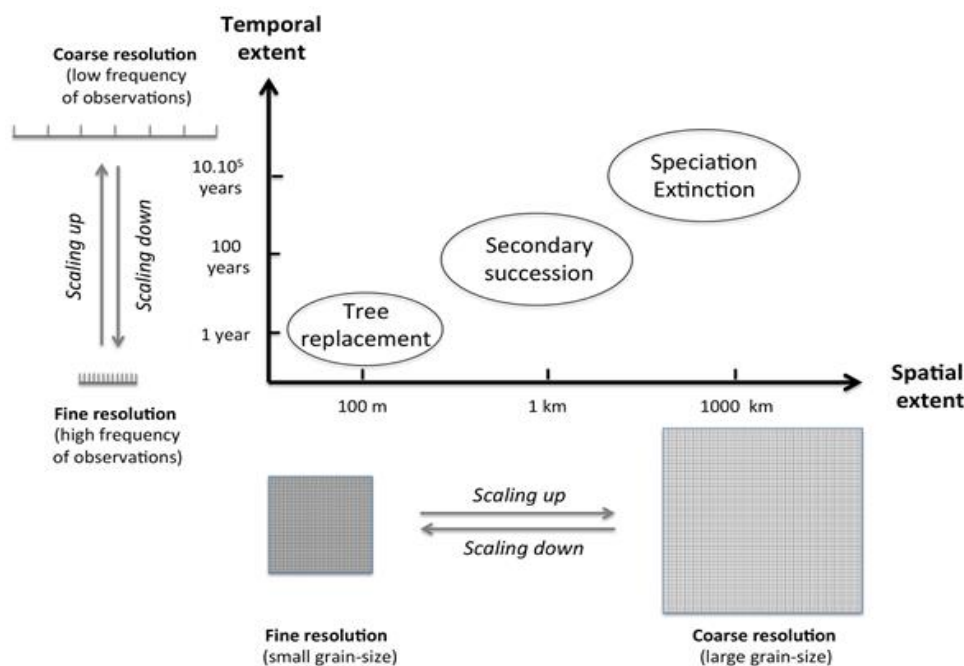

Figure 6.3: Four ecological processes (tree replacement, secondary succession, speciation and extinction) and their respective space-time domains. Large spatial and temporal extents are usually related with coarse spatial and temporal resolution data, in contrast to small spatial and temporal extents. Consequently scaling up is usually associated with an increase in spatial and temporal extent and decrease in resolution, while scaling down has as consequence a reduction in extent, which should be followed by an increase in resolution.

Cross-scaling is appropriate in situation where biodiversity dynamics and ecological processes acting at a particular domain of scales are also indirectly affected by processes acting in other scales (Section 6.4.1.4).

Local biodiversity pattern or ecosystem services, such as stocks and flows of water and other living resources, are mainly controlled by proximate factors acting locally, but are also affected by indirect global drivers of change (Levin, 1992), which would require data on large spatial extension and for an extended period of time. Inversely, local actions affect the environment globally, and as a consequence the success of global scenario projections will depend on the congruence of scenarios and goals planned at more local scales (Cash et al., 2006).

6.4.1.1 Social organizational scale

The underlying assumptions and mental models that people hold about the human-natural systems relationship drives the types of models and scenarios being accepted and developed (Hamilton, 2011) (see also IPBES Deliverable 3d on ‘diverse values and valuation’, <http://ipbes.net/>).

Several models have been proposed and adopted to provide knowledge about human-natural systems in a range of spatial-temporal-organizational dimension (Dietze et al., 2011). Some of these models are static, with snapshot changes (e.g., Computable General Equilibrium), linear with projected changes over time [e.g., VISIT, Integrated Valuation of Environmental Services and Trade-offs (InVEST) (Goldstein et al., 2010; Kareiva et al., 2011; Dean et al., 2012)] and system based models [e.g., World3 (Meadows et al., 1972), Global Unified Meta-model of the Biosphere (GUMBO) (Boumans et al., 2002) and Multi-scale Integrated Model of Ecosystem Services (MIMES) (Box 6.3) (Boumans and Costanza, 2007; Altman et al., 2014)].

Box 6.3: Multi-scale Integrated Model for Ecosystem Services (MIMES) for Manawatu watershed, New Zealand

The Manawatu River watershed is located in the North island of New Zealand and is home to about 200,000 people and the land intensively used for agriculture, particularly dairying. Historically, steep hills were forested, but forest is now down to 20% of the original cover (Dymond, 2010). In 2009, researchers ranked it as the worst of 300 rivers tested for daily change in dissolved oxygen (Clapcott and Young, 2009). In response, the regional government initiated a collaborative process to bring together stakeholder to improve the conditions of the river.

In 2009, a newspaper article labelled the Manawatu the ‘river of shame’. Researchers had ranked it as the worst of 300 rivers tested for daily change in dissolved oxygen (Clapcott and Young, 2009). In response, the regional government initiated a collaborative process to bring together stakeholder which became the Manawatu River Leadership Forum. This coincided in timing with Ministry of Business, Innovation and Employment funding Ecological Economics Research New Zealand to undertake the ‘Integrated Freshwater Solutions’ (IFS) action research project.

Mediated Modelling approach was used to support the collaborative effort to understand the underlying systems driving poor water quality (van den Belt, 2004), specifically those causing eutrophication, erosion and habitat destruction.

The Mediated Modelling scoping model was used to ‘play out’ some of the scenarios associated with the detailed ‘Action Plan’ signed off by the Manawatu River Leaders Forum. An example of policy scenario is provide funding to reduce erosion by retiring land and planting trees as part of the Sustainable Land Use Initiative.

The Mediated Modelling effort *with* stakeholders was subsequently translated and enhanced to develop a spatially explicit, dynamic Multi-scale Integrated Model for Ecosystem Services (MIMES) (Altman et al., 2014). MIMES uses Simile software and links multiple databases in a way that allows the bundling and trading of ecosystem services over time and space.

Here erosion control (as undertaken for example by the Sustainable Land Use Initiative programme) is mapped to highlight the change in ‘hotspots’ over time and space (Crossman and Bryan, 2009). The progression of model development from Mediated Modelling to MIMES required a transition from interpreting stakeholder perceptions to more data-intense, specialist, modelling by the science community.

Up- and down- scaling along a social organizational scale requires awareness of humanly imposed boundaries and conventions, which often are not following an ecosystem logic and may be difficult to be clearly defined (O'Brien and Vickerman, 2013).

For example, the usages of surface and ground water can have largely different spatial extent. In addition, governing bodies are often guided by multiple ways in which their constitutions are divided in space; e.g., the Auckland Council identified 30 different ways in which space is divided for water management (including water supply, water treatment, storm water, river/coastal and groundwater protection and various values from interest groups such as people from the Maori culture) (van den Belt et al., 2011). As such, optimal operational scales for model and scenarios differ in different organizational context and they should be ‘fit for purpose’.

Ecosystem services approach can be considered an organizing principle for harmonization of models or their outputs along an organizational scale (Costanza et al., 1997; Daily, 1997; MA, 2005; Braat and de Groot, 2012).

An ecosystem services approach is also inherently multi-scale as ecosystem services can be classified according to their spatial characteristics (Costanza, 2008; see Figure 6.4). (1) At a global level, climate regulation, carbon sequestration and storage as well as cultural or existence values do not depend on people’s proximity to the ecosystems from where the services originate, whereas (2) local proximity is relevant for disturbance regulation / storm protection, waste treatment, pollination, biological control and habitat. (3) A directional flow characterises water regulation/ flood protection, water supply, sediment retention/erosion control or nutrient regulation. (4) a point of use is relevant for soil formation, food/forest production and other raw material and finally (5) some ecosystem services and the benefits/values derived from them are related to the manner in which users move in space (and time), e.g., genetics resources, recreational potential and cultural values.

Due to its complexity, the scope for approaches aiming for optimization is limited and the process of model building with stakeholders becomes equally important as the model itself (van den Belt, 2004).

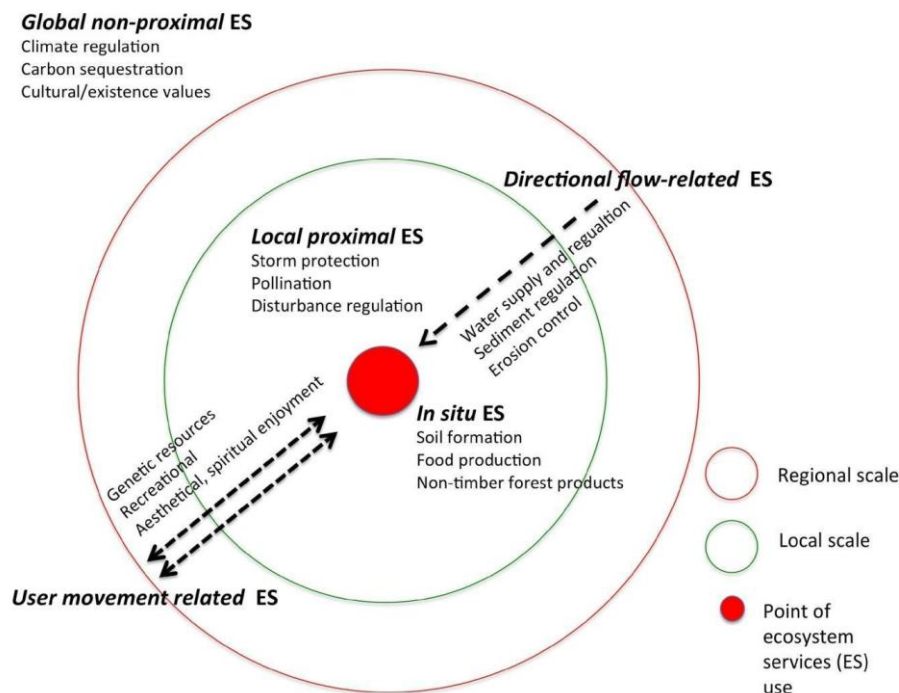

Figure 6.4: Multiscale ecosystem services approach classified according to their spatial characteristics (adapted from Costanza, 2008).

6.4.1.2 Spatial scale

Downscaling

Spatial downscaling is a common technique to provide spatial information for local conservation issues or management needs, such as establishing priority conservation areas, when high resolution information is not available (Rondinini et al., 2005; Bombi et al., 2012; Fernandes et al., 2014).

For example, downscaling is relevant to incorporating projections of climate models into local conservation planning (Wiens and Bachelet, 2010; Walz et al., 2014). There is a long history of developing downscaling methods for climate data that provides valuable experience for downscaling of biodiversity and ecosystem services models and scenarios (Box 6.4). Downscaling has also been applied to biodiversity assessment, such as the downscaling of Red List Index (RLI) from global to national scale (Han et al., 2014; Rodrigues et al., 2014).

Box 6.4 Interpolation of local information from global information

Introduction of global information by establishing statistical transfer functions is an efficient approach to improve the estimation error of ecological variables for locations where primary data is not available. A statistical analysis of precipitation data from the 661 meteorological stations (Figure Box 6.4a) demonstrates that precipitation has a close relationship with topographic aspect, latitude, longitude and elevation. The statistical transfer functions of mean annual precipitation under a Box-Cox transformation was derived as a combination of minimized residuals output by a method for high accuracy surface modelling with the Geographically Weighted Regression using latitude, longitude, elevation, impact coefficient of aspect and sky view factor as independent variables. The introduction of spatial non-stationarity analyses into the interpolation of meteorological stations has greatly improved the interpolated climate surfaces (Figure Box 6.4c). For instance, inverse distance weighting was applied to interpolation of mean annual precipitation in China during the period from 1960 to 2010, taking a digital elevation model (DEM) as secondary data (Figure Box 6.4b); mean absolute error of the mean annual precipitation was 102.23 mm. The mean relative error of the interpolated mean annual precipitation decreased by 3% due to the combination of Geographically Weighted Regression with inverse distance weighting; in addition, when high accuracy surface modelling is used, which has much better performance comparing with the classical methods such as inverse distance weighting, Kriging and Spline, the accuracy of the interpolated mean annual precipitation has been increased by 3% (Yue et al., 2013; Zhao and Yue, 2014). In other words, an introduction of both Geographically Weighted Regression and high accuracy surface modelling can make the accuracy of the interpolated mean annual precipitation increased by 6% totally.

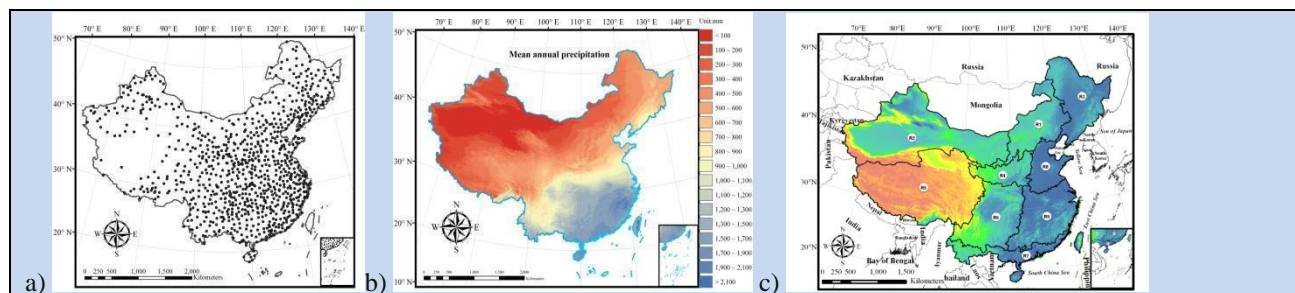

Figure Box 6.4: a) Spatial distribution of the meteorological stations with location information in China, b) Digital elevation model of China, c) Surface of mean annual precipitation in China the necessary global information have been extracted from the local information by geo-statistics.

Most often downscaling techniques are based on interpolation of statistical relationships between specific model or scenario metrics and predictors with higher resolution data.

For example, the expected distribution of a species inside its geographic range can be inferred from high resolution data on the distribution of its habitat; thus downscaling the information to the scale of the habitat maps (e.g., Rondinini et al., 2005; Rondinini et al., 2011). A similar approach is obtained with hierarchical modelling (Keil and Jetz, 2014; Keil et al., 2013), which projects the relationship between coarse-grain species and environmental data to a finer grain using fine-grain environmental (predictor) variables. This method was used for downscaling exploited fishes and invertebrates' distributions in Western Australia (Cheung et al., 2012). Similarly, Barwell et al. (2014) downscaled a coarse-grained ($> 100 \text{ km}^2$) Odonata atlas data to a more fine-grain (25 km^2 , 4 km^2 and 1 km^2) local scale in mainland Britain, suggesting reasonable estimates of fine-grain occupancy, with varying errors according to species traits. Recent studies showed high predictive performance of downscaling models in comparison with field observations of invasive alien species (Fernandes et al., 2014), birds (Keil et al., 2013), Sardinian reptiles (Bombi et al., 2012), and global marine circulation (Sandø et al., 2014). Specific methods such as Hierarchical Bayesian Modelling (HBM) approach is shown to improve the performance of downscaling over other statistical methods (Keil et al., 2013). Those predictions may be further improved when combined with macro-ecological relationships (e.g., scale area relationships) (Keil et al., 2013).

Dynamic downscaling that is based on mechanistic models may be more appropriate than statistical downscaling in systems where the relationship between coarse scale and fine scale dynamics are complex and non-linear or observational data are insufficient.

Dynamics downscaling uses fine-resolution dynamical models to estimate fine-scale dynamical features (Stock et al., 2011). Available methods of downscaling involve developing fine-scale models that are forced with coarse global climate simulations, or forcing a fine-resolution model component with information from coarse resolution model. The coupling between coarse and fine scale models can be 'one-way' or 'two-way'. Dynamic downscaling has been applied widely in regional climate and oceanographic modelling. On one hand, dynamic downscaling offers consistency of the solutions and reliance upon fundamental principles of physics, chemistry, biology and ecology. On the other hand, it requires higher computational cost of running the models. Also, the coupled coarse-fine scale models are more complex and costly to develop. Furthermore, while dynamical downscaling may improve the representation of fine-scale dynamics, it is still strongly influenced by any biases in the coarse-scale simulations used for the boundary forcing.

While downscaling methodology is well developed, there is a trade-off between the cost to collect data and develop models at fine scale on one hand, and the uncertainty of downscaled outputs on the other.

The decision on which scale to adopt ultimately depends on the resources available and the acceptable level of error, which can be quantified by validation of the downscaled model with sampled high resolution data.

Upscaling

Environmental problems or the consequences of human activities sometimes encompass broad spatial and temporal scales, which need global assessments and policy actions. For this reason, it is often necessary to transfer local high-resolution data to broader scales, which is called spatial upscaling (Flint and Flint, 2012).

Upscaling methods are more intuitive than downscaling ones, as they involve extrapolating values over a larger space. Upscaling methods can be categorized into four main types: coarse graining, lagging, accumulating and rating (Figure 6.5). Coarse graining increases the spatial extent of the unit. Lagging increases the separation between units. Accumulating sums all the finer scale values within a larger spatial extent. Rating compares data on distinct units that differ in size of some other characteristic to develop scaling functions (Schneider, 2009).

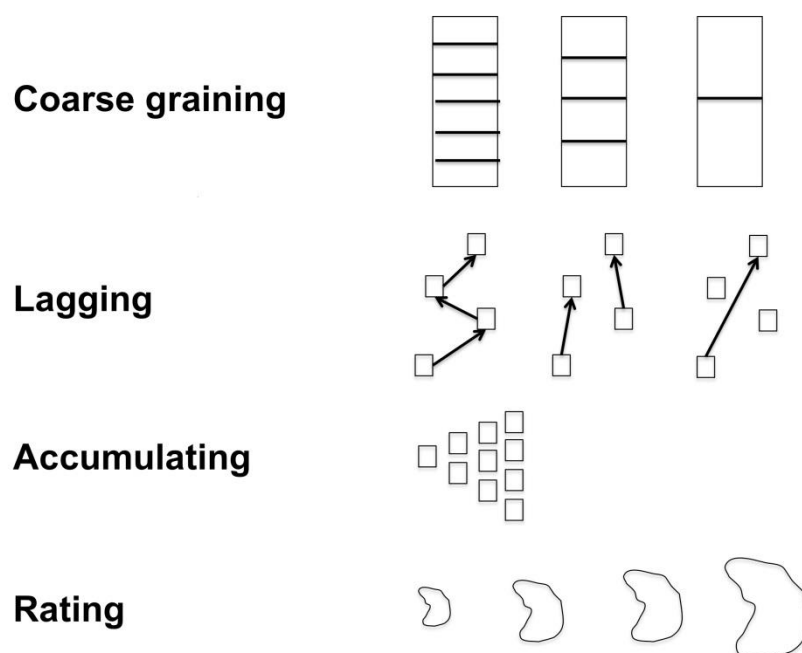

Figure 6.5: Comparison of four main methods of upscaling (redrawn from Schneider 2009).

Spatial upscaling approaches have been commonly applied to analyse satellite imagery and combine statistical and image processing analyses with simulation models and field observations (Zhang et al., 2007; Chen et al., 2010; Fu et al., 2014).

For example, upscaling has been used to estimate net ecosystem exchange or carbon dioxide fluxes from flux towers to landscape and regional scales (Fu et al., 2014). In another example, a simple exponential relationship between Leaf Area Index (LAI) and the Normalized Difference Vegetation Index (NDVI) obtained with a Landsat image was used to upscale LAI values to Arctic landscapes (Williams et al., 2008). Other methods have been developed to upscale gross ecosystem production (GEP) from leaf or stand levels to larger regions (ca. 12 km²) taking into account tree canopy structure (Hilker et al., 2008), using Light Detection and Ranging (LiDAR) images. Results showed a high correlation (r^2 between 0.75 and 0.91, $p < 0.05$) between estimated and measured ecosystem production. A good fit between upscaled estimated values and field measurements was also obtained with net primary productivity in China, showing that the integration of field data with remote sensing through an ecosystem model can generate reliable estimates (Zhang et al., 2007). Upscaling can result in better estimates than those obtained from coarse-grained resolution images, such as those obtained from satellite remote sensing data from the Moderate Resolution Imaging Spectroradiometer (MODIS) (Fu et al., 2014), possibly because they can integrate the variability observed at finer scales in the coarse-scale evaluation. Similar results were obtained by Hay et al. (1997) when upscaling forest stand characteristics with image resampling techniques. They showed that appropriately upscaled satellite imagery can represent a more accurate estimation than an image obtained at the upscaled resolution. However, it is costly to have fine scale information for large extent for upscaling to reveal broad scale pattern.

In the process of upscaling, quantitative approaches to preserve the quality of the original information should be applied whenever possible; otherwise it can contribute to scaling uncertainties (Section 6.5).

For example, using an approach called modelled net ecosystem exchange, properties of mean, variance and skewness of fine-scale normalized difference vegetation index in an Arctic tundra landscape is preserved (Stoy et al., 2009)

6.4.1.3 Temporal scale

Quantifying and forecasting temporal change in biodiversity and ecosystem services through linking and harmonizing models and scenarios at an appropriate scale are important not only to address ecological issues, but also to develop policies and achieve global conservation goals.

Depending on the properties of direct and indirect drivers (Chapters 3 and 4), the mechanisms through which these drivers result in changes in biodiversity and ecosystem services, and the policy context, the appropriate temporal scales for models and scenarios vary (from daily, monthly, annual, decadal and centennial).

Upscaling

Upscaling methods across temporal scales are in principle similar to those for spatial scale which include accumulating, coarse-graining, lagging and rating (Figure 6.5).

Accumulating involves summing data or model outputs from finer temporal intervals to present longer-term average conditions. For example, species occurrence records are accumulated over a long time-period (e.g., multiple decades) before being used to predict current distribution range. Coarse-graining involves averaging estimates over smaller temporal units e.g., averaging annual climate data to calculate climatology. For lagging, multiple snap-shots are used to present changes over a longer time period. In some cases, these snap-shots could be generated from a diversity of sources, ranging from formal quantitative measurements, model outputs, or expert knowledge. For rating, quantitative functions are developed to rescale finer temporal resolution data to estimates over longer time period. For example, time trends of point information on soil solution data were scaled by linking them to soil chemical data which was available in higher temporal resolution, using both statistical and process-oriented methods (Zirlewagen and von Wilpert, 2010).

When fine-scale data or outputs are available, the cost of temporal upscaling is relatively low; however, the temporal characteristics of the data across scales should be considered carefully.

Otherwise, upscaling may contribute to scaling error (see 6.5). Specifically, the temporal variance of the data may be smoothed after upscaling. For example, seasonal differences in net primary production will not be represented in annual averages. On the other hand, higher internal variability may also need larger temporal samples for upscaling.

Downscaling

Downscaling temporal data is primarily based on numerical (mechanistic) models, statistical analysis and stochastic algorithms.

For instance, Rebera et al. (2006), developed a new spatial-temporal downscaling procedure, called RainFARM to flood forecasting, as alternative to stochastic algorithms. RainFARM generates small scale rain rate fluctuations that preserves the spatio-temporal evolution of rainfall patterns. Mendes and Marengo (2010) proposed an alternative to numerical models, and developed a temporal neural network for downscaling global climate outputs (downscaling daily precipitation time series). A novel conceptual and analytical model of biodiversity loss based on the landscape ontogeny, Terragen, is currently being developed by Rosa et al. (2013) and aims to generate biodiversity scenarios for the humid tropics, partially based on downscaling temporal data on biodiversity loss and deforestation models. However, most existing examples of temporal downscaling are related to modelling of drivers such as climate, while examples of biodiversity and ecosystem services models and scenarios are limited.

6.4.1.4 Cross-scale interactions

When system processes (biophysical and/or social-economic) interact across scales (spatial, temporal or organizational), resulting in nonlinear dynamics, harmonizing of models and their outputs across these scales is more prompt to scaling error (Peters et al., 2007), see section 6.5.2). In such cases, the use of multiple scale models performs better than single scale models.

For example, Boscolo and Metzger (2009) showed that multiscale models that considered pattern-process relationships at different extents in a unique model always performed better than single-scale model to predict the occurrences of bird species in a tropical forest. This is likely because extinction and recolonization processes that control species occurrences simultaneously act at different scales. There are many other examples of important ecological processes that are modulated by processes that interact across scales, such as bark beetle eruptions (Raffa et al., 2008), parasitism (Tompkins et al., 2011), fire disturbances (Falk et al., 2007), runoff and erosion processes (Allen, 2007) (see Box 6.5).

Box 6.5: Regional assessments that includes both global information and local information

Ecosystem services are controlled by a combination of global and local factors. The system dynamics that generate the ecosystem services cannot be recovered from the global or local controls alone (Phillips, 2002). In this box, we illustrate how harmonizing models across multiple scales can improve the accuracy of the model outputs.

Results from satellite-observation-based approach (global scale) (Piao et al., 2009) and a local-information-based approach (local scale) (Fang et al., 2001) were combined means of high accuracy surface modelling (Yue, 2011). China's national forest inventory database from 2004 to 2008 includes 160,000 permanent sample plots and 90,000 temporary sample plots scattered over the land surface of China. The cross-validation was comprised of four steps: (i) 5% of the sample plots of each forest type in each province were removed for validation prior to model creation; (ii) the spatial distribution of average forest carbon stocks (CS) in China during the period 2004-2008 was simulated at a spatial resolution of 5km×5km using the remaining 95% of the sample plots; (iii) the mean absolute error and mean relative error were calculated using the 5% validation set; and (iv) the 5% validation set was returned to the pool of available sample plots for the next iteration, and another 5% validation set was removed. This process was repeated until all of the sample plots were used for validation at least one time and the simulation error statistics for each sample plot could be calculated.

The mean absolute errors of the carbon stock surfaces, generated by the satellite-observation-based approach global-information-based method (Figure Box 6.5a) and the Kriging local-information-based method (Figure Box 6.5b), are respectively 1.9 and 2.0 $\text{kg}\cdot\text{m}^{-2}$. When the local information is combined into satellite-observation-based approach by means of high accuracy surface modelling, which is denoted below as high accuracy surface modelling - satellite-observation-based approach (Figure Box 6.5c), the mean absolute error is decreased to 0.9 $\text{kg}\cdot\text{m}^{-2}$. The mean relative errors of both the global and local-information-based methods have been reduced by at least 53% because the local and global information were fused by means of high accuracy surface modelling.

In terms of high accuracy surface modelling - satellite-observation-based approach, annual mean carbon stocks of all forest types in China was 7.1 Pg during the period 2004-2008, given contributions of 2.7, 4.0, and 0.4 Pg from coniferous, broadleaf and mixed forests, respectively. Similarly, the annual mean carbon density was 4.6 kg/m^2 during the period 2004-2008, with contributions of 4.4, 4.7, and 4.2 kg/m^2 from coniferous, broadleaf, and mixed forests respectively. The satellite-observation-based approach underestimates annual mean carbon stocks, whereas Kriging overestimates the annual mean carbon stocks of China.

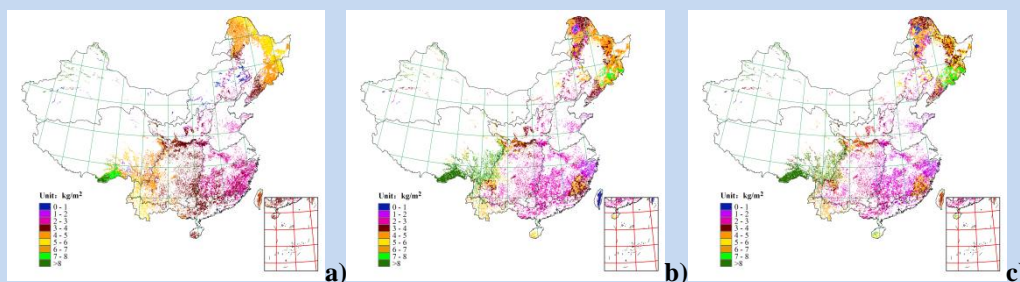

Figure Box 6.5: Surfaces of carbon stocks created by different methods: a) satellite-observation-based approach, b) Kriging and c) high accuracy surface modelling - satellite-observation-based approach

Multi-scale models can also be used to represent interactions between human organizational scales in assessment of ecosystem services.

The management of salmon resource in the Columbia River Basin, USA, is a good example (Rieman et al., 2001). Conflict within and among groups of individuals and organizations that have different interests, values, and power can be viewed as an interacting hierarchical structure. Particularly, the interests of local loggers, fishers and environmentalists are in conflict with the interests of those who are planning hydropower utilities, as well as pitting native fishers against offshore fishermen and environmental groups (Rieman et al., 2001), resulting in non-linear dynamics of the social-ecological system (Peters et al., 2007).

The use of multi-scale modelling approaches can help to consider the different factors and their interactions that are important at different scales. A drawback in using multi-scale model is that cross-scale interacting processes are difficult to model accurately and may result in error propagation as model complexity increases (see section 6.5.2).

6.4.2 Harmonization of scenarios

To compare, synthesize or combine existing assessments of biodiversity and ecosystem services that use scenarios with different objectives, policy questions, assumptions, uncertainties, or focus on different temporal and spatial scales, the scenarios need to be harmonized first.

Scenarios that are related to biodiversity and ecosystem services have been produced and used in different international (e.g., Millennium Ecosystem Assessment), national (e.g., the United Kingdom's Alternative Future Scenarios for Marine Ecosystems, Pinnegar et al. (2006) and local assessments (e.g., Manawatu basin management, Box 6.3). The differences in objectives e.g., assessing greenhouse gas emission or fisheries sustainability, assumptions, and use of different scenario development methodology may render direct comparison between these scenarios difficult. Many initiatives employed different methodologies in developing scenarios, even between different iterations of the assessment, depending primarily on the goals, spatial scales, social-economic and policy context, and resources available for the scenario development exercises (Biggs et al., 2007) (see Chapter 3). On the other hand, these scenarios may need to be combined for comprehensive assessments that include different elements and domains relating to biodiversity, ecosystem services and human well-being (Figure 6.1). Harmonization of these scenarios thus becomes important.

Existing scenarios belonging to the same archetype or family can be harmonized to provide more comprehensive descriptions of possible futures (Biggs et al., 2007).

Available literature on standardizing and harmonizing scenarios for environmental assessments suggested three main steps: (1) identify and discuss the application of the scenarios and their main characteristics (2) compare the key assumptions and storylines behind the scenarios, and (3) compare the trends observed in the main scenario methodology in relation to policy making (van Vuuren et al., 2012). Scenarios can be categorized into 'scenario

families' or archetypes according to their underlying assumptions, storyline, logic, and characteristics. Some of the key assumptions and variables in which these scenarios differ include risk-perception and resulting policy actions to environmental change, spatial scale of drivers and systems, their trends, and degree of cooperation in the society (Biggs et al., 2007; van Vuuren et al., 2012).

Scenarios describing plausible futures for different spatial scales can be harmonized, although existing literature largely discusses methods for downscaling. To downscale scenarios (Biggs et al., 2007), scenario pathways at large scale can be used as boundary conditions to frame developments of finer-scale scenarios.

This ensures that outcomes of the regional scenarios do not conflict with those of the global scenarios. Also, in some cases, with the help of experts and/or stakeholders participation, large scale scenario pathway can be contextualized and applied to specific region or issues. For example, through an interdisciplinary expert workshop, different Shared Socio-economic Pathways (SSPs) developed for the IPCC were converted into different scenario pathways for ocean and fisheries. Moreover, scenarios at different scale may be developed without much reference to one another but they can then be mapped together (see section 6.4). In other cases, large scale scenarios can be applied directly to examine regional policies without the need for development of complete regional scenarios e.g., application of Representative Concentration Pathways (RCPs) to assess climate change impacts at both global and regional scales.

Mapping of scenarios onto archetypes or families could be facilitated using tabular or graphical representation.

For example, existing scenarios for global environmental assessments include the Global Scenario Group (GSG)'s work on Great Transitions (Raskin et al., 2002; Raskin, 2005), the IPCC Special Report on Emissions Scenarios (SRES) (Nakićenović and Swart, 2000), UNEP's Third Global Environmental Outlook (GEO3) (UNEP, 2002) and the World Water Vision work (Cosgrove and Rijsberman, 2014; van Vuuren et al., 2012) (Table 6.3). To harmonize these scenarios, firstly, they are characterized by eight broad attributes: economic development, population growth, technological development, main objectives, environmental protection, trade, policies and institutions, and vulnerability to climate change (rows in Table 6.3). Based on these attributes, they can be categorized into different archetypes or scenario families: Global Sustainable Development, Business As Usual, Regional Competition, Economic Optimism, Reformed Markets and Regional Sustainability (different columns in Table 6.3). The IPCC has developed multiple sets of socio-economic scenarios for different assessment reports e.g., Special Report on Emission Scenarios (SRES, developed in Fourth Assessment Report) and Shared Socio-economic Pathways (SSPs, developed in the Fifth Assessment Report) (O'Neill et al., 2014). These IPCC scenarios can be characterized and mapped graphically according to the underlying socio-economic challenges for mitigation and adaption of each scenario (Figure 6.6).

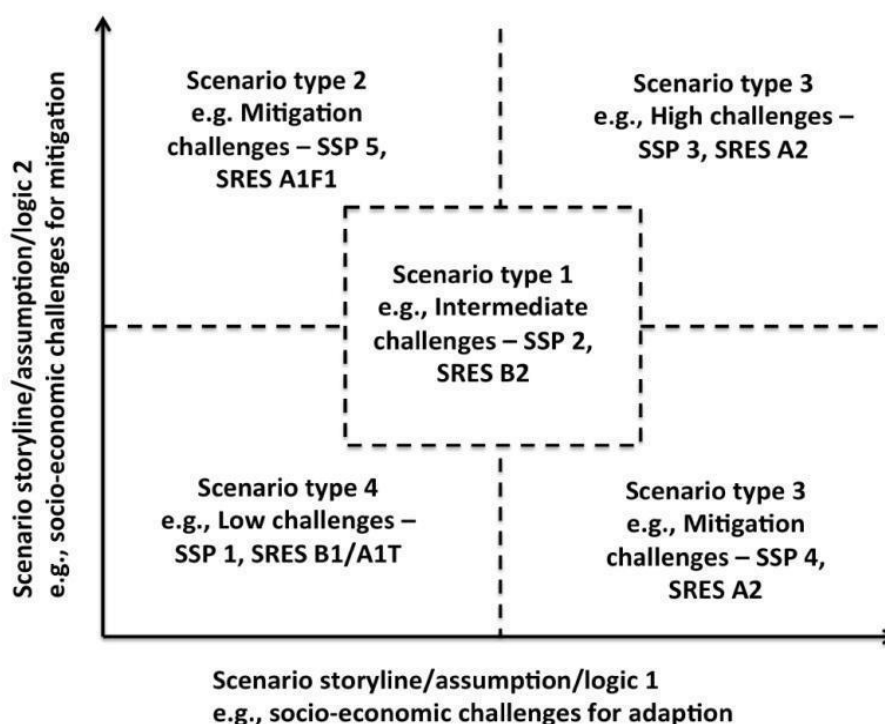

Figure 6.6. An example illustrating the mapping of scenarios onto scenario families or archetype based on the storyline, assumption and logic of the scenarios. The example is on mapping the Special Report on Emissions

Scenarios (SRES) and Shared Socio-economic Pathways (SSPs) developed by the IPCC (based on O'Neill et al., 2014).

Table 6.3

Archetypes or families of scenarios from previous global environmental assessments and their key characteristics and assumptions (adopted from van Vuuren et al., 2012).

Archetype/scenario family	Global sustainable development	Business as usual	Regional competition	Economic optimism	Reformed markets	Regional sustainability
Economic development	Ranging from slow to rapid	Medium	Slow	Very Rapid	Rapid	Medium
Population growth	Medium	High	Low	Low	Low	Medium
Technological development	Ranging from medium to rapid	Medium	Slow	Rapid	Rapid	Ranging from slow to rapid
Main objectives	Global sustainability	Not defined	Security	Economic growth	Various goals	Local sustainability
Environmental protection	Proactive	Both reactive and proactive	Reactive	Reactive	Both reactive and proactive	Proactive
Trade	Globalization	Weak globalization	Trade barriers	Globalization	Globalization	Trade barriers
Policies and institutions	Strong global governance	Mixed	Strong national governments	Policies create open markets	Policies target market failures	Local action
Vulnerability to climate change	Low	Medium	Mixed – varies regionally	Local action	Low	Low
Examples						
SSPs	SSP1	SSP2	SSP3/SSP4	SSP5		
SRES	B1 (A1T)	B2	A2	A1F1		B2
GEO3/GEO4	Sustainability First		Security First	Market First	Policy First	
Global Scenario Group	New Sustainability Paradigm		Barbarization	Conventional World	Policy Reform	Eco-communalism
Millennium assessment	Techno-garden		Order from Strength		Global Orchestration	Adapting Mosaic

Some of the methods for downscaling scenarios can also be applied to upscale scenarios from finer to broader spatial scales, however, existing examples of scaling of scenario have greater emphasis on downscaling than on upscaling, limiting the available experience that could be drawn on.

Generally, to upscale finer scale scenarios to large spatial scale, teams of developers can collaboratively develop finer scale scenarios that are consistent across regions. These local and regional scale scenarios then collectively provide description of future at global level. This method of upscaling can minimize conflict of local scale context with larger scale assumptions, while diversity of local scale context can be represented. However, substantial resources and effort are needed to coordinate the development and aggregation of multiple local scale scenarios. In the case of multi-scale scenarios, different scenarios components are kept at their most appropriate scale (space and time) with linkages between scales being established upfront (Biggs et al., 2007).

6.4.3 Benchmarking of models

Benchmarking is the process of systematically comparing sets of model predictions against measured data in order to evaluate model performance. It should also help to identify processes that may be poorly represented in models (McCarthy et al., 2012).

Benchmarking is common practice in fields other than ecology: for example, Global Circulation Models included in the IPCC need to be able to hind-cast historic temperature trends, derived from multiple sources. In scenario work, model predictions are sometimes weighted by the model performance in relation to the benchmarks (e.g., Rammig et al., 2010). General guidelines for benchmarking environmental models have been developed by Bennett et al. (2013)

and a particular framework for land (ecosystem) models by Luo et al. (2012), but we are not aware of any multi-model benchmarking activity with biodiversity models at the species level or ecosystem service models. The framework proposed by Luo and colleagues as part of the International Land Model Benchmarking (ILAMB) project includes 1) targeted aspects of model performance to be evaluated, (2) a set of benchmarks as defined references to test model performance, (3) metrics to measure and compare performance skills among models, and (4) model improvement. To improve the credibility of species-based biodiversity and ecosystem service models, benchmarking should be further developed. Species distribution models, for example, could be tested against observed historical changes in species ranges (Chen et al., 2011). This also highlights the needs for good empirical data such as from remote sensing (e.g., satellite products and aerial photos).

Benchmarking should be accompanied by standardized model documentation and archiving of model source codes, input data, model results and model result processing tools.

For biogeochemical models, such as global terrestrial carbon cycle models, guidelines for developing standardized archives were suggested by Thornton et al. (2005). For biodiversity and ecosystem service models, the current situation is unsatisfactory. Even though the results from numerical models should in principle be 100% reproducible, this is often not the case, e.g., because complex models are often under constant development, implying that references to published model descriptions are outdated. Archives for this purpose still have to be developed (Thornton et al., 2005).

6.5 Uncertainty in linking and harmonizing models

6.5.1 Cascade of uncertainty from models linking biodiversity and ecosystem services

Uncertainties originated from different biodiversity and ecosystem services models that are linked across spatial and temporal scales, elements and domains may potentially propagate through the chains of models, affecting the ultimate envelope of uncertainty (Figure 6.7).

To allow the application of model linkages to provide useful outputs to inform and assist decision making on biodiversity and ecosystem services issues, sound estimates or assessment of uncertainty are needed (Dunford et al., 2014). Typology of uncertainties is described in Chapter 1 while details of uncertainty associated with specific model components are described in Chapters 2 – 5.

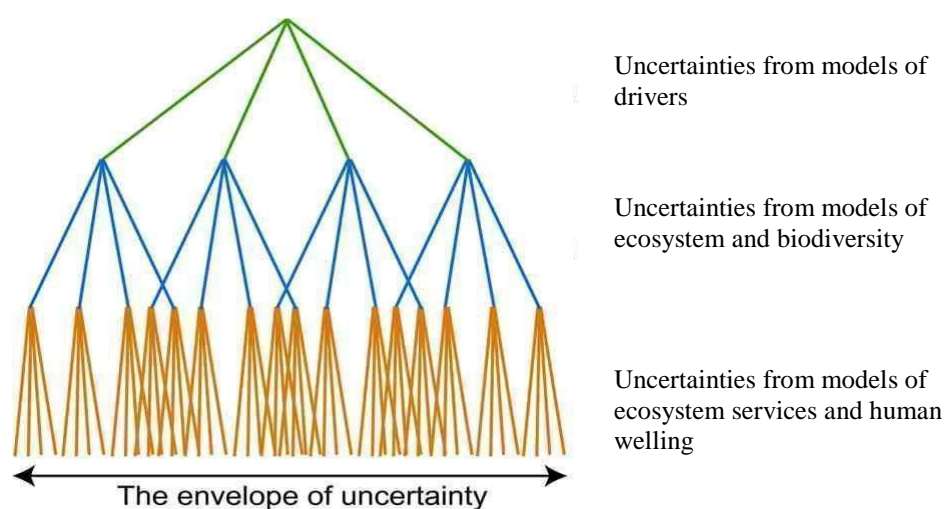

Figure 6.7: Cascade of uncertainties of linking drivers, biodiversity and ecosystem services models.

The width of the envelope of uncertainty is dependent on the nature of interactions between linked models and their uncertainties.

The types of interactions include linearity of the linkages, existence of threshold responses and positive/negative feedbacks (Peters and Herrick, 2004). When the processes linking two or more models are non-linear, uncertainties may be dampened or magnified through model linkages, for example, through attenuation or amplification of changes in higher trophic level production in marine ecosystems driven by climate change (Chust et al., 2014; Stock et al., 2014). A special case of non-linearity in which thresholds in triggering responses between models exist, the envelope of uncertainty may become more difficult to explore as thresholds are often difficult to specify. Feedbacks in social-ecological systems can be positive or negative, and uncertainties propagated in models that are linked dynamically with feedbacks resulting in emergent dynamics that are difficult to predict. Ignoring or mis-specifying the types of linkages will reduce the reliability of the linked model outputs.

Available options to address errors associated with linking models include not linking the models, limiting the extent of model linkages, and exploring the envelope of uncertainty resulting from model linkages (Peters and Herrick, 2004).

Selection of these options requires careful consideration of the need and marginal benefits of model linkages and the trade-offs in errors between model over-simplification and the increased uncertainty from more complex models; this requires systematic exploration of different types of uncertainties associated with the linked model. Such exploration involves formal numerical approaches (e.g., comparison of model outputs with past observations and/or through analysis of large model ensembles) and/or expert judgement (Dunford et al., 2014). For example, in a cross-sectoral, regional-scale Integrated Assessment Platform for the assessment of climate change impacts, the use of a well-designed approaches to combine numerical analysis and expert opinion in addressing model uncertainties could improve the usefulness of the model outputs for decision making and the understanding of the uncertainty associated with it (Dunford et al., 2014).

Limited availability of observational data sets may make it difficult to evaluate the reliability of outputs from linked models. In particular, data is challenged by issues of consistency between timeframe and spatial scales and confounding effects of multiple human pressures such as climate and fishing.

The limitations of available data should not prevent application of the models nor deem all model projection unreliable, as projections also gain credibility through their reliance on robust ecological and physiological principles. It should, however, temper interpretation of results.

6.5.2 Scaling errors and uncertainty

In downscaling or upscaling observations, models, or their outputs, the wider the order of magnitude of scale being harmonized, the higher is the risks of propagating errors (Jarvis, 1995).

Change in spatial or temporal scales result in change in heterogeneity in the patterns, with heterogeneity increases with finer grain (with a constant extent) or larger extent (with a constant grain). Scaling in systems with gradual transition of grain and extent, or that are scale invariance (such as fractal systems), is usually simple and can be done with relatively simple regression functions. For example, it is well known that the size and frequency of disturbances are inversely related (e.g., large-scale disturbances are less frequent than small-scale disturbances), and this can be easily represented by a power-law function (White et al., 2008). However, scaling between two or more level of scales, where non-linear changes in heterogeneity occur, may be much more challenging to apprehend with simple mathematical models, and thus can lead to significant errors propagation. Thus, harmonization across wide range of scales or with large heterogeneity in grains and/or extent is not recommended (Wiens, 1989). National or local policy makers should be cautious in rely on downscaled data to made decisions to are sensitive to high scaling error such as spatial planning (see Chapter 2)

Upscaling or downscaling models with processes that interact between different spatial or temporal scales will increase scaling error.

Carbon flux from woody debris, for example, is simultaneously affected by climate, site environment and species-specific variations in wood characteristics (Weedon et al., 2009), and by the interactions of those processes that occur at different spatial and temporal scales. As a consequence, any upscaling or downscaling framework will need to consider interactions among those processes to properly model carbon dynamics. In this sense, it could be useful to consider species traits that regulate wood and decomposition characteristics at a more local (plot) scale even in global terrestrial carbon cycle models (Weedon et al., 2009).

As such, it is important to understand and identify any thresholds of scaling above which fundamental shifts in underlying processes that regulate the studied system would occur (Wu et al., 2006). In these cases, one may need to invest in using mechanistic scaling approaches that explicitly model and represent the interactions between scales in the system.

An additional source of scaling errors is the incorrect use assumption of scaling functions, particularly in predicting species distributions. Such errors can be reduced by careful selection of modelling and scaling methods.

For example, spatial aggregations of organisms can lead to bias estimates of their abundance if the scaling process is nonlinear (Stoy et al., 2009). Errors are commonly more severe when projecting the absence and occurrence of the organisms, compared to their global range. Indeed, downscaling usually tends to lead to an overestimation of species distributions (Sardà-Palomera et al., 2012). However, precise information on species distribution at a local level is crucial for local decision making (Franklin et al., 2013), such as for identifying biodiversity hotspots (Sardà-Palomera et al., 2012). In those cases, a more complex framework, combining niche and spatial models with spatially explicit fine-grain approaches is necessary to reduce errors when modelling species locations (Azaele et al., 2012). Different techniques have been proposed to deal with species' spatial aggregation, such as the scale transition theory (Melbourne

and Chesson, 2006) and the shot noise Cox processes (SNCP), which allow a better prediction of population estimates at fine scales starting from coarser ones ((Azaele et al., 2012).

Ground observations and global models on coarse spatial resolutions are important sources for data of simulating changes of biodiversity and ecosystem services (Box 6.4). However, too sparsely distributed ground observations are often unable to satisfy the data requirements of regional or local stakeholders and decision makers. One major problem is on how values for locations where reliable estimates cannot be generate by interpolation can be estimated.

Many global models are difficult to use at regional and local levels because their spatial resolutions are too coarse or region-specific important processes are missing.

For regional applications, regionally tested downscaled global models or region- and site-specific models have to be developed (e.g., Hickler et al., 2012; Seiler et al., 2014). High-quality ground observation data and model benchmarking at the desired scale is crucial for any of the two approaches.

6.6 Conclusions

Because of the complexity of systems relevant for assessing the current status and trends of biodiversity and ecosystem services and for developing future scenarios, it is often necessary to link models or scenarios representing their different components. Models and scenarios that integrate feedbacks and trade-offs across temporal and spatial scales and among dynamic societal economic and natural systems can address particularly complex challenges and guide decision making. Ultimately, the question of whether, how and to what extent biodiversity and ecosystem service models should be harmonized and linked depends on the research and policy objectives. Integration of quantitative models, qualitative approaches and expert knowledge has great potential to advance our understanding and predictions of biodiversity and ecosystem services. To facilitate the development of methods for linking and harmonizing scenarios and models, we need to build communities of multi-disciplinary researchers and practitioners to support such research and decision support.

The rapidly growing number of model intercomparison projects is an opportunity to foster the harmonization of models and cultivate a community to make advancements in the long-term. However, existing intercomparison projects are sectorally focused, e.g., for carbon cycling, forest productivity, agriculture or fisheries. Strengthening the linkages between biophysical and human domains is a major challenge. There are increasing efforts in this area such as IAMs and ecosystem services assessments. However, more extensive development and application of these approaches should be encouraged to accelerate the state-of-the-art in linking models and scenarios across social and natural domains.

References

- Ainsworth, C.H., Samhouri, J.F., Busch, D.S., Cheung, W.W.L., Dunne, J. and Okey, T.A., 2011: Potential impacts of climate change on Northeast Pacific marine foodwebs and fisheries. *ICES Journal of Marine Science: Journal du Conseil*: fsr043.
- Alkemade, R., Van Oorschot, M., Miles, L., Nellemann, C., Bakkenes, M. and ten Brink, B., 2009: GLOBIO3: A Framework to Investigate Options for Reducing Global Terrestrial Biodiversity Loss. *Ecosystems*, **12**(3): 374-390.
- Allen, C.D., 2007: Interactions across spatial scales among forest dieback, fire, and erosion in northern New Mexico landscapes. *Ecosystems*, **10**(5): 797-808.
- Altman, I., Boumans, R., Roman, J., Gopal, S. and Kaufman, L., 2014: An Ecosystem Accounting Framework for Marine Ecosystem-Based Management. In *The Sea*, President and Fellows of Harvard College, 245-276.
- Azaele, S., Cornell, S.J. and Kunin, W.E., 2012: Downscaling species occupancy from coarse spatial scales. *Ecological Applications*, **22**(3): 1004-1014.
- Barwell, L.J., Azaele, S., Kunin, W.E., Isaac, N.J.B. and Richardson, D., 2014: Can coarse-grain patterns in insect atlas data predict local occupancy? *Diversity and Distributions*, **20**(8): 895-907.
- Bennett, N.D., Croke, B.F.W., Guariso, G., Guillaume, J.H.A., Hamilton, S.H., Jakeman, A.J., Marsili-Libelli, S., Newham, L.T.H., Norton, J.P. and Perrin, C., 2013: Characterising performance of environmental models. *Environmental Modelling & Software*, **40**: 1-20.
- Biggs, R., Raudsepp-hearne, C., Atkinson-palombo, C., Bohensky, E., Boyd, E., Cundill, G., Fox, H., Ingram, S., Kok, K., Spehar, S., Tengö, M., Timmer, D. and Zurek, M., 2007: Linking Futures across Scales: a Dialog on Multiscale Scenarios. *Ecology and Society*, **12**(1): 17 pages.
- Bombi, P., Salvi, D., Bologna, M.A. and Pettorelli, N., 2012: Cross-scale predictions allow the identification of local conservation priorities from atlas data. *Animal Conservation*, **15**(4): 378-387.
- Boscolo, D. and Metzger, J.P., 2009: Is bird incidence in Atlantic forest fragments influenced by landscape patterns at multiple scales? *Landscape Ecology*, **24**(7): 907-918.
- Boumans, R. and Costanza, R., 2007: The multiscale integrated Earth Systems model (MIMES): the dynamics, modeling and valuation of ecosystem services. *Issues in Global Water System Research*, **2**: 10-11.
- Boumans, R., Costanza, R., Farley, J., Wilson, M.A., Portela, R., Rotmans, J., Villa, F. and Grasso, M., 2002: Modeling the dynamics of the integrated earth system and the value of global ecosystem services using the GUMBO model. *Ecological Economics*, **41**(3): 529-560.
- Bouwman, A.F., Kram, T. and Klein Goldewijk, K., 2006: *Integrated modelling of global environmental change: An overview of IMAGE*. Bilthoven, Netherlands Environmental Assessment Agency (MNP).
- Braat, L.C. and de Groot, R., 2012: The ecosystem services agenda: bridging the worlds of natural science and economics, conservation and development, and public and private policy. *Ecosystem Services*, **1**(1): 4-15.
- Butchart, S.H.M., Akçakaya, H.R., Chanson, J., Baillie, J.E.M., Collen, B., Quader, S., Turner, W.R., Amin, R., Stuart, S.N. and Hilton-Taylor, C., 2007: Improvements to the Red List Index. *PLoS ONE*, **2**(1): e140.
- Carpenter, S.R., Bennett, E.M. and Peterson, G.D., 2006: Scenarios for ecosystem services: an overview. *Ecology and Society*, **11**(1): 29.
- Cash, D.W., Adger, W.N., Berkes, F., Garden, P., Lebel, L., Olsson, P., Pritchard, L. and Young, O., 2006: Scale and cross-scale dynamics: governance and information in a multilevel world. *Ecology and Society*, **11**(2): 8.
- Chen, B., Ge, Q., Fu, D., Yu, G., Sun, X., Wang, S. and Wang, H., 2010: A data-model fusion approach for upscaling gross ecosystem productivity to the landscape scale based on remote sensing and flux footprint modelling. *Biogeosciences*, **7**(9): 2943-2958.
- Chen, I.C., Hill, J.K., Ohlemüller, R., Roy, D.B. and Thomas, C.D., 2011: Rapid range shifts of species associated with high levels of climate warming. *Science*, **333**(6045): 1024-1026.
- Cheung, W.W.L., Lam, V.W.Y., Sarmiento, J.L., Kearney, K., Watson, R.E.G., Zeller, D. and Pauly, D., 2010: Large-scale redistribution of maximum fisheries catch potential in the global ocean under climate change. *Global Change Biology*, **16**(1): 24-35.

- Cheung, W.W.L., Meeuwig, J.J., Feng, M., Harvey, E., Lam, V.W.Y., Langlois, T., Slawinski, D., Sun, C. and Pauly, D., 2012: Climate-change induced tropicalisation of marine communities in Western Australia. *Marine and Freshwater Research*, **63**(5): 415-427.
- Chust, G., Allen, J., Bopp, L., Schrum, C., Holt, J., Tsiaras, K., Zavatarelli, M., Chifflet, M., Cannaby, H. and Dadou, I., 2014: Biomass changes and trophic amplification of plankton in a warmer ocean. *Global Change Biology*, **20**(7): 2124-2139.
- Clapcott, J.E. and Young, R.G., 2009: Temporal variability in ecosystem metabolism of rivers in the Manawatu-Wanganui Region. Cawthron Institute, Cawthron Report No. 1672 1-877516-78-3,
- Collen, B., Loh, J., Whitmee, S., McRae, L., Amin, R. and Baillie, J.E.M., 2009: Monitoring Change in Vertebrate Abundance: the Living Planet Index. *Conservation Biology*, **23**(2): 317-327.
- Cosgrove, W.J. and Rijsberman, F.R., 2014: *World water vision: making water everybody's business*. Routledge.
- Costanza, R., 2008: Ecosystem services: multiple classification systems are needed. *Biological Conservation*, **141**(2): 350-352.
- Costanza, R., d'Arge, R., de Groot, R., Farber, S., Grasso, M., Hannon, B., Limburg, K., Naeem, S., O'Neill, R.V., Paruelo, J., Raskin, R.G., Sutton, P. and van den Belt, M., 1997: The value of the world's ecosystem services and natural capital. *Nature*, **387**(6630): 253-260.
- Crossman, N.D. and Bryan, B.A., 2009: Identifying cost-effective hotspots for restoring natural capital and enhancing landscape multifunctionality. *Ecological Economics*, **68**(3): 654-668.
- Crossman, N.D., Burkhard, B., Nedkov, S., Willemen, L., Petz, K., Palomo, I., Drakou, E.G., Martín-Lopez, B., McPhearson, T., Boyanova, K., Alkemade, R., Egoh, B., Dunbar, M.B. and Maes, J., 2013: A blueprint for mapping and modelling ecosystem services. *Ecosystem Services*, **4**: 4-14.
- Daily, G., 1997: *Nature's services: societal dependence on natural ecosystems*. Island Press.
- Dean, A., Barano, T., Bhagabatai, N., McKenzie, E., Van Paddenburg, A., Rosenthal, A. and Salim, A., 2012: *InVEST Scenarios Case Study: Borneo, Indonesia*. Stanford, CA, WWF.
- Dearing, J.A., Wang, R., Zhang, K., Dyke, J.G., Haberl, H., Hossain, M.S., Langdon, P.G., Lenton, T.M., Raworth, K. and Brown, S., 2014: Safe and just operating spaces for regional social-ecological systems. *Global Environmental Change*, **28**: 227-238.
- Dietze, M.C., Vargas, R., Richardson, A.D., Stoy, P.C., Barr, A.G., Anderson, R.S., Arain, M.A., Baker, I.T., Black, T.A., Chen, J.M., Ciais, P., Flanagan, L.B., Gough, C.M., Grant, R.F., Hollinger, D., Izaurralde, R.C., Kucharik, C.J., Lafleur, P., Liu, S., Lokupitiya, E., Luo, Y., Munger, J.W., Peng, C., Poulter, B., Price, D.T., Ricciuto, D.M., Riley, W.J., Sahoo, A.K., Schaefer, K., Suyker, A.E., Tian, H., Tonitto, C., Verbeeck, H., Verma, S.B., Wang, W. and Weng, E., 2011: Characterizing the performance of ecosystem models across time scales: A spectral analysis of the North American Carbon Program site-level synthesis. *Journal of Geophysical Research: Biogeosciences*, **116**(G4): G04029.
- Doherty, R.M., Sitch, S., Smith, B., Lewis, S.L. and Thornton, P.K., 2010: Implications of future climate and atmospheric CO₂ content for regional biogeochemistry, biogeography and ecosystem services across East Africa. *Global Change Biology*, **16**(2): 617-640.
- Dunford, R., Harrison, P.A. and Rounsevell, M.D.A., 2014: Exploring scenario and model uncertainty in cross-sectoral integrated assessment approaches to climate change impacts. *Climatic Change*, **132**(3): 417-432.
- Dymond, J.R., 2010: Soil erosion in New Zealand is a net sink of CO₂. *Earth Surface Processes and Landforms*, **35**(15): 1763-1772.
- Falk, D.A., Miller, C., McKenzie, D. and Black, A.E., 2007: Cross-scale analysis of fire regimes. *Ecosystems*, **10**(5): 809-823.
- Fernandes, R.F., Vicente, J.R., Georges, D., Alves, P., Thuiller, W. and Honrado, J.P., 2014: A novel downscaling approach to predict plant invasions and improve local conservation actions. *Biological Invasions*, **16**(12): 2577-2590.
- Flint, L.E. and Flint, A.L., 2012: Downscaling future climate scenarios to fine scales for hydrologic and ecological modeling and analysis. *Ecological Processes*, **1**(1): 1-15.
- Franklin, J., Davis, F.W., Ikegami, M., Syphard, A.D., Flint, L.E., Flint, A.L. and Hannah, L., 2013: Modeling plant species distributions under future climates: how fine scale do climate projections need to be? *Global Change Biology*, **19**(2): 473-483.

- Fu, D., Chen, B., Zhang, H., Wang, J., Black, T.A., Amiro, B.D., Bohrer, G., Bolstad, P., Coulter, R., Rahman, A.F., Dunn, A., McCaughey, J.H., Meyers, T. and Verma, S., 2014: Estimating landscape net ecosystem exchange at high spatial–temporal resolution based on Landsat data, an improved upscaling model framework, and eddy covariance flux measurements. *Remote Sensing of Environment*, **141**: 90-104.
- Fulton, E.A., Link, J.S., Kaplan, I.C., Savina-Rolland, M., Johnson, P., Ainsworth, C., Horne, P., Gorton, R., Gamble, R.J. and Smith, A.D.M., 2011: Lessons in modelling and management of marine ecosystems: the Atlantis experience. *Fish and Fisheries*, **12**(2): 171-188.
- Goldstein, J., Caldarone, G., Daily, G., Duarte, K., Hannahs, S. and McKenzie, E., 2010: *InVEST Scenarios Case Study: Hawaii, USA*. Stanford, CA, WWF.
- Hamilton, L.C., 2011: Education, politics and opinions about climate change evidence for interaction effects. *Climatic Change*, **104**(2): 231-242.
- Han, X., Smyth, R.L., Young, B.E., Brooks, T.M., Sánchez de Lozada, A., Bubb, P., Butchart, S.H.M., Larsen, F.W., Hamilton, H., Hansen, M.C. and Turner, W.R., 2014: A Biodiversity Indicators Dashboard: Addressing Challenges to Monitoring Progress towards the Aichi Biodiversity Targets Using Disaggregated Global Data. *PLoS ONE*, **9**(11): e112046.
- Hanewinkel, M., Cullmann, D.A., Schelhaas, M.-J., Nabuurs, G.-J. and Zimmermann, N.E., 2012: Climate change may cause severe loss in the economic value of European forest land. *Nature Climate Change*, **3**(3): 203-207.
- Harfoot, M., Tittensor, D.P., Newbold, T., McInerney, G., Smith, M.J. and Scharlemann, J.P.W., 2014: Integrated assessment models for ecologists: the present and the future. *Global Ecology and Biogeography*, **23**(2): 124-143.
- Hay, G.J., Niernann, K.O. and Goodenough, D.G., 1997: Spatial thresholds, image-objects, and upscaling: a multiscale evaluation. *Remote Sensing of Environment*, **62**(1): 1-19.
- Heubusch, K., 2006: Interoperability What it Means, Why it Matters. *JOURNAL-AHIMA*, **77**(1): 26.
- Hickler, T., Vohland, K., Feehan, J., Miller, P.A., Smith, B., Costa, L., Giesecke, T., Fronzek, S., Carter, T.R., Cramer, W., Kühn, I. and Sykes, M.T., 2012: Projecting the future distribution of European potential natural vegetation zones with a generalized, tree species-based dynamic vegetation model. *Global Ecology and Biogeography*, **21**(1): 50-63.
- Hilker, T., Coops, N.C., Hall, F.G., Black, T.A., Chen, B., Krishnan, P., Wulder, M.A., Sellers, P.J., Middleton, E.M. and Huemmrich, K.F., 2008: A modeling approach for upscaling gross ecosystem production to the landscape scale using remote sensing data. *Journal of Geophysical Research*, **113**(G3): G03006.
- Hurtt, G.C., Chini, L.P., Froking, S., Betts, R.A., Feddema, J., Fischer, G., Fisk, J.P., Hibbard, K., Houghton, R.A., Janetos, A., Jones, C.D., Kindermann, G., Kinoshita, T., Klein Goldewijk, K., Riahi, K., Shevliakova, E., Smith, S., Stehfest, E., Thomson, A., Thornton, P., van Vuuren, D.P. and Wang, Y.P., 2011: Harmonization of land-use scenarios for the period 1500–2100: 600 years of global gridded annual land-use transitions, wood harvest, and resulting secondary lands. *Climatic Change*, **109**(1-2): 117-161.
- Jarvis, P.G., 1995: Scaling processes and problems. *Plant, Cell & Environment*, **18**(10): 1079-1089.
- Kareiva, P., Tallis, H., Ricketts, T.H., Daily, G.C. and Polasky, S., 2011: *Natural Capital: Theory and Practice of Mapping Ecosystem Services*. Oxford, UK., Oxford University Press.
- Keil, P. and Jetz, W., 2014: Downscaling the environmental associations and spatial patterns of species richness. *Ecological Applications*, **24**(4): 823-831.
- Keil, P., Belmaker, J., Wilson, A.M., Unitt, P. and Jetz, W., 2013: Downscaling of species distribution models: a hierarchical approach. *Methods in Ecology and Evolution*, **4**(1): 82-94.
- Laniak, G.F., Olchin, G., Goodall, J., Voinov, A., Hill, M., Glynn, P., Whelan, G., Geller, G., Quinn, N. and Blind, M., 2013: Integrated environmental modeling: a vision and roadmap for the future. *Environmental Modelling & Software*, **39**: 3-23.
- Levin, S., 2003: Complex adaptive systems: exploring the known, the unknown and the unknowable. *Bulletin of the American Mathematical Society*, **40**(1): 3-19.
- Levin, S.A., 1992: The problem of pattern and scale in ecology: the Robert H. MacArthur award lecture. *Ecology*, **73**(6): 1943-1967.
- Luo, Y.Q., Randerson, J.T., Friedlingstein, P., Hibbard, K., Hoffman, F., Huntzinger, D., Jones, C.D., Koven, C., Lawrence, D. and Li, D.J., 2012: A framework for benchmarking land models. *Biogeosciences*, **9**: 3857-3874.

- MA, 2005: *Ecosystems and Human Well-being: Synthesis*. Washington, DC, Island Press.
- Mace, G.M., Norris, K. and Fitter, A.H., 2012: Biodiversity and ecosystem services: a multilayered relationship. *Trends in Ecology & Evolution*, **27**(1): 19-26.
- Matott, L.S., Babendreier, J.E. and Purucker, S.T., 2008: Evaluating uncertainty in integrated environmental models: a review of concepts and tools. *Water Resources Research*, **45**: W06421.
- McCarthy, H.R., Luo, Y. and Wullschleger, S.D., 2012: Integrating empirical-modeling approaches to improve understanding of terrestrial ecology processes. *The New phytologist*, **195**(3): 523-525.
- Meadows, D.H., Meadows, D.L., Randers, J. and Behrens, W.W., 1972: *The limits to growth*. Washington DC, Potomac Associates.
- Melbourne, B.A. and Chesson, P., 2006: The scale transition: scaling up population dynamics with field data. *Ecology*, **87**(6): 1478-1488.
- Mendes, D. and Marengo, J., 2010: Temporal downscaling: a comparison between artificial neural network and autocorrelation techniques over the Amazon Basin in present and future climate change scenarios. *Theoretical and Applied Climatology*, **100**(3-4): 413-421.
- Nakićenović, N. and Swart, R., 2000: *Special report on emission scenarios. A special report of working group III of the Intergovernmental Panel on Climate Change*. Cambridge, UK, Cambridge University Press.
- O'Brien, S. and Vickerman, S., 2013: From principles to practice: developing a vision and policy framework to make ecosystem management a reality. In *The laws of nature : reflections on the evolution of ecosystem management law and policy*, Robbins, K., ed., Akron, Ohio, The University of Akron Press.
- O'Neill, B.C., Kriegler, E., Riahi, K., Ebi, K.L., Hallegatte, S., Carter, T.R., Mathur, R. and van Vuuren, D.P., 2014: A new scenario framework for climate change research: the concept of shared socioeconomic pathways. *Climatic Change*, **122**(3): 387-400.
- PBL, 2012: Roads from Rio+ 20: Pathways to achieve global sustainability goals by 2050. PBL Netherlands Environmental Assessment Agency, The Hague.
- Peters, D.P.C. and Herrick, J.E., 2004: Strategies for ecological extrapolation. *Oikos*, **106**(3): 627-636.
- Peters, W., Jacobson, A.R., Sweeney, C., Andrews, A.E., Conway, T.J., Masarie, K., Miller, J.B., Bruhwiler, L.M.P., Pétron, G., Hirsch, A.I., Worthy, D.E.J., van der Werf, G.R., Randerson, J.T., Wennberg, P.O., Krol, M.C. and Tans, P.P., 2007: An atmospheric perspective on North American carbon dioxide exchange: CarbonTracker. *Proceedings of The National Academy of Sciences*, **104**(48): 18925-18930.
- Pinnegar, J.K., Viner, D., Hadley, D., Sye, S., Harris, M., Berkhout, F. and Simpson, M., 2006: *Alternative future scenarios for marine ecosystems*. Lowestoft, Cefas.
- Raffa, K.F., Aukema, B.H., Bentz, B.J., Carroll, A.L., Hicke, J.A., Turner, M.G. and Romme, W.H., 2008: Cross-scale Drivers of Natural Disturbances Prone to Anthropogenic Amplification: The Dynamics of Bark Beetle Eruptions. *Bioscience*, **58**(6): 501-517.
- Rammig, A., Jupp, T., Thonicke, K., Tietjen, B., Heinke, J., Ostberg, S., Lucht, W., Cramer, W. and Cox, P., 2010: Estimating the risk of Amazonian forest dieback. *The New phytologist*, **187**(3): 694-706.
- Raskin, P., Banuri, T., Gallopin, G., Gutman, P., Hammond, A., Kates, R. and Swart, R., 2002: Great transition Umbrüche und Übergänge auf dem Weg zu einer planetarischen Gesellschaft. Institut für sozial-ökologische Forschung (ISOE), Materialien Soziale Ökologie, Frankfurt am Main.
- Raskin, P.D., 2005: Global Scenarios- Background Review for the Millennium Ecosystem Assessment. *Ecosystems*, **8**(2): 133-142.
- Rebora, N., Ferraris, L., von Hardenberg, J. and Provenzale, A., 2006: RainFARM: Rainfall downscaling by a filtered autoregressive model. *Journal of Hydrometeorology*, **7**(4): 724-738.
- Rieman, B., Peterson, J.T., Clayton, J., Howell, P., Thurow, R., Thompson, W. and Lee, D., 2001: Evaluation of potential effects of federal land management alternatives on trends of salmonids and their habitats in the interior Columbia River basin. *Forest Ecology and Management*, **153**(1-3): 43-62.
- Rodrigues, A.S.L., Brooks, T.M., Butchart, S.H.M., Chanson, J., Cox, N., Hoffmann, M. and Stuart, S.N., 2014: Spatially Explicit Trends in the Global Conservation Status of Vertebrates. *PLoS ONE*, **9**(11): e113934.
- Rondinini, C., Stuart, S. and Boitani, L., 2005: Habitat suitability models and the shortfall in conservation planning for African vertebrates. *Conservation Biology*, **19**(5): 1488-1497.

- Rondinini, C., Boitani, L., Rodrigues, A.S.L., Brooks, T.M., Pressey, R.L., Visconti, P., Baillie, J.E.M., Baisero, D., Cabeza, M., Crooks, K.R., Marco, M.D., Redford, K.H., Andelman, S.A., Hoffmann, M., Maiorano, L., Stuart, S.N. and Wilson, K.A., 2011: Reconciling global mammal prioritization schemes into a strategy. *Philosophical Transactions of the Royal Society B: Biological Sciences*, **366**(1578): 2722-2728.
- Rosa, I.M.D., Purves, D., Souza, C. and Ewers, R.M., 2013: Predictive modelling of contagious deforestation in the Brazilian Amazon. *PLoS ONE*, **8**(10): e77231.
- Sandø, A., Melsom, A. and Budgell, W., 2014: Downscaling IPCC control run and future scenario with focus on the Barents Sea. *Ocean Dynamics*, **64**(7): 927-949.
- Sardà-Palomera, F., Brotons, L., Villero, D., Sierdsema, H., Newson, S. and Jiguet, F., 2012: Mapping from heterogeneous biodiversity monitoring data sources. *Biodiversity and Conservation*, **21**(11): 2927-2948.
- Schneider, D.C., 2009: *Quantitative ecology: measurement, models and scaling*. New Foundland, Canada, Academic press.
- Seiler, C., Hutjes, R.W.A., Kruijt, B., Quispe, J., Anez, S., Arora, V.K., Melton, J.R., Hickler, T. and Kabat, P., 2014: Modeling forest dynamics along climate gradients in Bolivia. *Journal of Geophysical Research - Biogeosciences*, **119**: 758-775.
- Steffen, W., Richardson, K., Rockström, J., Cornell, S.E., Fetzer, I., Bennett, E.M., Biggs, R., Carpenter, S.R., de Vries, W., de Wit, C.A., Folke, C., Gerten, D., Heinke, J., Mace, G.M., Persson, L.M., Ramanathan, V., Reyers, B. and Sörlin, S., 2015: Sustainability. Planetary boundaries: guiding human development on a changing planet. *Science (New York, N.Y.)*, **347**(6223): 1259855.
- Stehfest, E., Van Vuuren, D., Kram, T., Bouwman, L., Alkemade, R., Bakkenes, M., Biemans, H., Bouwman, A., Den Elzen, M., Janse, J., Lucas, P., Van Minnen, J., Müller, C. and Prins, A.G., 2014: *Integrated Assessment of Global Environmental Change with IMAGE 3.0. Model description and policy applications*. The Hague, PBL Netherlands Environmental Assessment Agency.
- Stock, C.A., Dunne, J.P. and John, J.G., 2014: Global-scale carbon and energy flows through the marine planktonic food web: An analysis with a coupled physical–biological model. *Progress in Oceanography*, **120**: 1-28.
- Stock, C.A., Alexander, M.A., Bond, N.A., Brander, K.M., Cheung, W.W.L., Curchitser, E.N., Delworth, T.L., Dunne, J.P., Griffies, S.M., Haltuch, M.A., Hare, J.A., Hollowed, A.B., Lehodey, P., Levin, S.A., Link, J.S., Rose, K.A., Rykaczewski, R.R., Sarmiento, J.L., Stouffer, R.J., Schwing, F.B., Vecchi, G.A. and Werner, F.E., 2011: On the use of IPCC-class models to assess the impact of climate on Living Marine Resources. *Progress in Oceanography*, **88**(1-4): 1-27.
- Stoy, P., Williams, M., Disney, M., Prieto-Blanco, A., Huntley, B., Baxter, R. and Lewis, P., 2009: Upscaling as ecological information transfer: a simple framework with application to Arctic ecosystem carbon exchange. *Landscape Ecology*, **24**(7): 971-986.
- Thornton, P.E., Cook, R.B., Braswell, B.H., Law, B.E., Corvallis, W.M., Shugart, H.H., Rhyne, B.T. and Hook, L.A., 2005: Archiving numerical models of biogeochemical dynamics. *Eos, Transactions American Geophysical Union*, **86**(44): 431-431.
- Tompkins, D.M., Dunn, A.M., Smith, M.J. and Telfer, S., 2011: Wildlife diseases: from individuals to ecosystems. *The Journal of animal ecology*, **80**(1): 19-38.
- UNEP, 2002: *Environmental Impact Assessment Training Resource Manual*. Second Edition. Geneva, Switzerland, United Nations Environmental Programme.
- van den Belt, M., 2004: *Mediated modeling: a system dynamics approach to environmental consensus building*. Island Press.
- van den Belt, M., Forgie, V., Bremer, S., McDonald, G., Oscar Montes de Oca, O. and Joy, M., 2011: Modelling tools for integrated, adaptive management: a case study of New Zealand Regional Authorities. Ecological Economics Research New Zealand, EERNZ Research Monograph Series 1, Palmerston North.
- van Vuuren, D.P., Kok, M.T.J., Girod, B., Lucas, P.L. and de Vries, B., 2012: Scenarios in Global Environmental Assessments: Key characteristics and lessons for future use. *Global Environmental Change*, **22**(4): 884-895.
- Visconti, P., Pressey, R.L., Giorgini, D., Maiorano, L., Bakkenes, M., Boitani, L., Alkemade, R., Falcucci, A., Chiozza, F. and Rondinini, C., 2011: Future hotspots of terrestrial mammal loss. *Philosophical Transactions of the Royal Society B: Biological Sciences*, **366**(1578): 2693-2702.
- Visconti, P., Bakkenes, M., Baisero, D., Brooks, T., Butchart, S.H.M., Joppa, L., Alkemade, R., Di Marco, M., Santini, L., Hoffmann, M., Maiorano, L., Pressey, R.L., Arponen, A., Boitani, L., Reside, A.E., van Vuuren,

- D.P. and Rondinini, C., 2015: Projecting Global Biodiversity Indicators under Future Development Scenarios. *Conservation Letters*, **Early View**.
- Voinov, A. and Shugart, H.H., 2013: 'Integronsters', integral and integrated modeling. *Environmental Modelling & Software*, **39**: 149-158.
- Walz, A., Braendle, J.M., Lang, D.J., Brand, F., Briner, S., Elkin, C., Hirschi, C., Huber, R., Lischke, H. and Schmatz, D.R., 2014: Experience from downscaling IPCC-SRES scenarios to specific national-level focus scenarios for ecosystem service management. *Technological Forecasting and Social Change*, **86**: 21-32.
- Weedon, J.T., Cornwell, W.K., Cornelissen, J.H.C., Zanne, A.E., Wirth, C. and Coomes, D.A., 2009: Global meta-analysis of wood decomposition rates: a role for trait variation among tree species? *Ecology Letters*, **12**(1): 45-56.
- White, E.P., Enquist, B.J. and Green, J.L., 2008: On estimating the exponent of power-law frequency distributions. *Ecology*, **89**(4): 905-912.
- Wiens, J.A., 1989: Spatial Scaling in Ecology. *Functional Ecology*, **3**(4): 385-397.
- Wiens, J.A. and Bachelet, D., 2010: Matching the multiple scales of conservation with the multiple scales of climate change. *Conservation Biology*, **24**(1): 51-62.
- Williams, M., Bell, R., Spadavecchia, L., Street, L.E. and Van Wijk, M.T., 2008: Upscaling leaf area index in an Arctic landscape through multiscale observations. *Global Change Biology*, **14**(7): 1517-1530.
- Wu, J., Jones, K.B., Li, H. and Loucks, O.L., 2006: Concepts of scale and scaling. In *Scaling and Uncertainty Analysis in Ecology: Methods and Applications*, Springer Science & Business Media, 3-15.
- Yue, T.-X., Zhao, N., Ramsey, R., Wang, C.-L., Fan, Z.-M., Chen, C.-F., Lu, Y.-M. and Li, B.-L., 2013: Climate change trend in China, with improved accuracy. *Climatic Change*, **120**(1-2): 137-151.
- Yue, T., 2011: *Modelling: High Accuracy and High Speed Methods*. New York, CRC Press.
- Zhang, N., Yu, Z., Yu, G. and Wu, J., 2007: Scaling up ecosystem productivity from patch to landscape: a case study of Changbai Mountain Nature Reserve, China. *Landscape Ecology*, **22**(2): 303-315.
- Zirlewagen, D. and von Wilpert, K., 2010: Upscaling of environmental information: support of land-use management decisions by spatio-temporal regionalization approaches. *Environmental Management*, **46**(6): 878-893.
- Zurek, M.B. and Henrichs, T., 2007: Linking scenarios across geographical scales in international environmental assessments. *Technological Forecasting and Social Change*, **74**(8): 1282-1295.

Chapter 7 Building capacity for developing, interpreting and using scenarios and models

Coordinating Lead Authors:

Carolyn Lundquist (New Zealand), Khaled Allam Harhash (Egypt)

Lead Authors:

Dolors Armenteras (Colombia), Nakul Chettri (Nepal), James Mwang'ombe Mwamodenyi (Kenya), Vasyl Prydatko (Ukraine), Sandra Acebey Quiroga (Bolivia), Andriambolantsoa Rasolohery (Madagascar)

Contributing Authors:

Kamaljit Kaur Sangha (Australia), Rosario Gomez (Peru), Fernando Santos-Martín (Spain), Shaun Awatere (New Zealand), Kathryn Davies (New Zealand)

Review Editor:

Nicholas King (South Africa)

Purpose of this chapter: Critically reviews key challenges, and potential solutions, for building capacity in the development and use of scenarios and models (covered in Chapters 2 to 6) across different scales and regions, and across a wide range of policy and decision-making contexts. This chapter also provides guidance on strategies to develop capacity for effective participation in the development and use of scenarios and models in IPBES assessments.

Target audience: A broader, less technical audience than for many of the other chapters in this report; but aimed particularly at readers seeking guidance on how best to build capacity in developing and using scenarios and models.

Key findings

Regional, sub-regional and national similarities and differences currently exist in the capacity for scenario development and modelling for biodiversity and ecosystem services. Human resources and technical skills required for scenario and modelling for biodiversity and ecosystem services are not evenly spread across regions. Differences in capacities for modelling and scenario analyses biodiversity and ecosystem services are most apparent in human resources, infrastructure and technical skills for biodiversity and ecosystem services modelling. External organisations may serve to fill gaps in capacity in nations with smaller economies through provision of technical and/or financial resources (7.1).

Ability to develop modelling and scenario analysis for biodiversity and ecosystem services is challenged by inadequate training and human capacity to utilise biodiversity and ecosystem services software and modelling tools. While many accessible and appropriate software and modelling tools exist, communication of their availability and training in their use is required (7.2).

Issues of accessibility and compatibility of datasets required for biodiversity and ecosystem services modelling and scenario analysis challenge the ability to develop models and scenarios, and to utilise data and model results in assessments. While many platforms have been developed to serve as repositories of biodiversity and ecosystem services datasets, duplication of effort is common, and inconsistencies between formatting and operating standards and lack of complementarity precludes optimal use of data platforms and their associated datasets in biodiversity and ecosystem services modelling and scenario analysis (7.3).

The development of biodiversity and ecosystem services modelling and scenario analysis is improving, but tools to incorporate biodiversity and ecosystem services concepts into national and global policy and decision making are under-developed and not commonly utilised. Training and development of the human capacity to integrate these tools can enable incorporation of these tools into policy and decision-making. Currently few scenario tools are available to policy makers that focus on biodiversity and ecosystem services; rather, most scenario analyses are focused on business or economic growth scenarios (7.4).

A wide range of qualitative and quantitative participatory tools is available to facilitate stakeholder engagement in biodiversity and ecosystem services scenario development. Involvement of diverse stakeholders and local and traditional knowledge communities in development of scenarios, including bidirectional communication that recognises and incorporates stakeholder needs into management and policy, is an integral part of successful scenario development (7.5).

Key recommendations

The Intergovernmental Platform on Biodiversity and Ecosystem Services (IPBES) Task Force on Capacity-Building should consider partnering with existing global programmes, partnerships and initiatives that provide opportunities for networking in respect to human resource and skills development. For example, the IPBES Task Force on Capacity-Building could work with existing Multilateral Environmental Agreements, international organisations and initiatives to provide resources to support joint training initiatives with IPBES to enable participation in the IPBES Work Programme. These partners provide a wide range of training courses, workshops, internships and collaborative projects, including training programmes for trainers. Long-term partnerships could be established with universities in developing and developed countries to train practitioners in tools and software for scenario development and modelling through the development of training courses and mentoring opportunities (7.2.2, 7.2.3, 7.5.3, 7.6.1, 7.6.2).

IPBES could promote capacity-building by providing guidelines and documentation for recommended tools for biodiversity and ecosystem services scenario development and modelling (models, software and databases). Translation of key documentation into each of the six United Nations (UN) languages and other non-UN languages would contribute greatly to capacity-building. These documents should use clear terminology that the users and

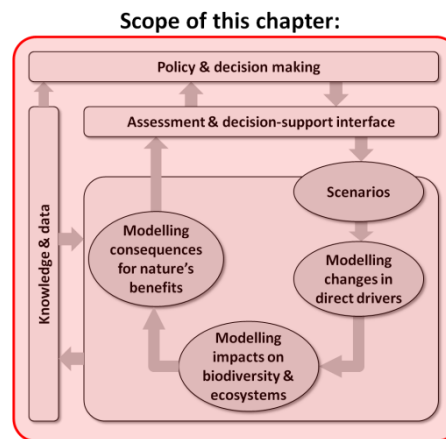

developers of models and scenarios can understand. IPBES could also develop and support networks and user forums for people to ask questions and interact with other users of models and scenarios, to promote knowledge exchange and development of capacity within and between regions. Case studies, including access to both model and scenario software and datasets, should be provided to build confidence in using models and scenarios. Intellectual property rights for tools should be determined, and broad access should be taken into account when making recommendations for those models, software and databases (7.2.1, 7.2.2, 7.6.1).

IPBES should consider identifying standardised global environmental datasets that are required to support IPBES assessments using models and scenarios of biodiversity and ecosystem services. In cooperation with other partners and donors, IPBES could develop guidelines for data collection to build and improve upon environmental datasets that underpin functional relationships between biodiversity and ecosystem services in IPBES models and assessments. Global and regional advisory platforms could be established to develop and adopt global standards and formats for global data and metadata, certify the quality of the datasets, and promote cloud technology with open access to these datasets required for recommended biodiversity and ecosystem services modelling and scenario tools and software (7.3.1, 7.3.2, 7.6.4).

The IPBES Catalogue of Policy Support Tools and Methodologies (Deliverable 3d) can build capacity by including guidelines and tools that enable incorporation of biodiversity and ecosystem services models and scenarios into decision-making processes. Guidelines and tools are required to identify effective strategies for mainstreaming scenario processes at different geographic scales and to allow their integration into participatory approaches, decision-making processes and public awareness across different policy, planning and management contexts. Identifying and providing capacity for integrating models and scenarios into decision-making needs to take into account the scale — local, regional and global — at which analyses and decision-making are made (7.4.1, 7.4.2, 7.5.3, 7.6.1).

In their efforts to engage and incorporate local and traditional knowledge communities in IPBES assessments, the IPBES Task Force on Indigenous and Local Knowledge Systems should consider the important role that scenarios and models can play in mobilizing local and indigenous knowledge. In particular, it would be important to identify and mobilize universities, research institutions and other stakeholders with experience or relationships in the formulation and use of scenarios or models that incorporate indigenous and local knowledge, as well as developing networks to share new methods that integrate diverse and multiple forms of knowledge. Scenarios and models can make important contributions to efforts by IPBES to enhance communication between indigenous and local communities, stakeholder groups and local governments, as well as efforts to build capacity of indigenous and local knowledge networks through leadership and educational opportunities (7.4.3, 7.4.4, 7.5.1, 7.5.2, 7.5.4, 7.6.3, 7.6.5).

7.1 Introduction

Previous chapters have introduced the methodologies for scenario analysis and modelling of biodiversity and ecosystem services, discussing a wide range of tools that can be used to support IPBES assessment and decision making, and support other user communities that could benefit from biodiversity and ecosystem services scenarios and models. This chapter reviews the underlying capacity required to support scenario analysis and modelling across a broad range of spatial scales (global, regional and sub-regional), and decision-making contexts.

Key capacities required for scenario analysis and modelling include: enhancing the capacity to develop and use scenarios in assessments, including strengthening human resources and infrastructure; improving access to and guidelines for user-friendly software tools for scenario analysis, modelling and decision-support systems; improving regional and national access to and inter-operability of quality standardised datasets; developing methods for better incorporation of local data and knowledge; and developing synergies with existing assessments for data and scenario sharing.

Key capacities also include development of effective strategies for mainstreaming scenario processes at different geographic scales to allow their integration into participatory approaches, decision-making processes and public awareness across different policy, planning and management contexts (Brooks *et al.* 2014). This chapter discusses the human resources, infrastructure and data accessibility required to enable biodiversity and ecosystem services scenario analysis and modelling at the regional, sub-regional and national scales.

7.1.1 Capacity-building for biodiversity and ecosystem services scenario analysis and modelling

The United Nations Development Programme (UNDP) defines capacity development for environmental sustainability as ‘the process through which individuals, organisations and societies obtain, strengthen and maintain their capabilities to set and achieve their own development objectives over time.

Components of capacity include skills, systems, structures, processes, values, resources and powers that together confer a range of political, managerial and technical capabilities (UNDP, 2011). Within IPBES the Task Force on Capacity-Building has identified five key capacity-building categories: 1) capacity to participate effectively in

implementing the IPBES work programme; 2) capacity to carry out and use national and regional assessments; 3) capacity to locate and mobilise financial and technical resources; 4) capacity to access data, information and knowledge; and 5) capacity for enhanced and meaningful multi-stakeholder engagement (IPBES/3/18, Decision IPBES-3/1 Annex I, <http://ipbes.net/>).

Within the context of biodiversity and ecosystem services scenario analysis and modelling, capacity development includes human resources and technical capacity required to support scenario analysis and modelling across a broad range of spatial scales (global, regional, sub-regional, national and local) and decision-making contexts (Figure 7.1). Skills in data collection, such as those of ecologists and taxonomists who collect data related to flora and fauna, as well as soil scientists and other experts, underpin the databases required to develop scenarios and models.

Capacity-building for scenario analysis and modelling also includes capacity to support development of effective strategies for mainstreaming scenario processes at different geographic scales. There are many entry points and strategies for developing scenarios and models across scales (Table 7.1), and many entry points to allow their integration into participatory approaches, decision-making processes and public awareness across different policy, planning and management contexts (Table 7.2).

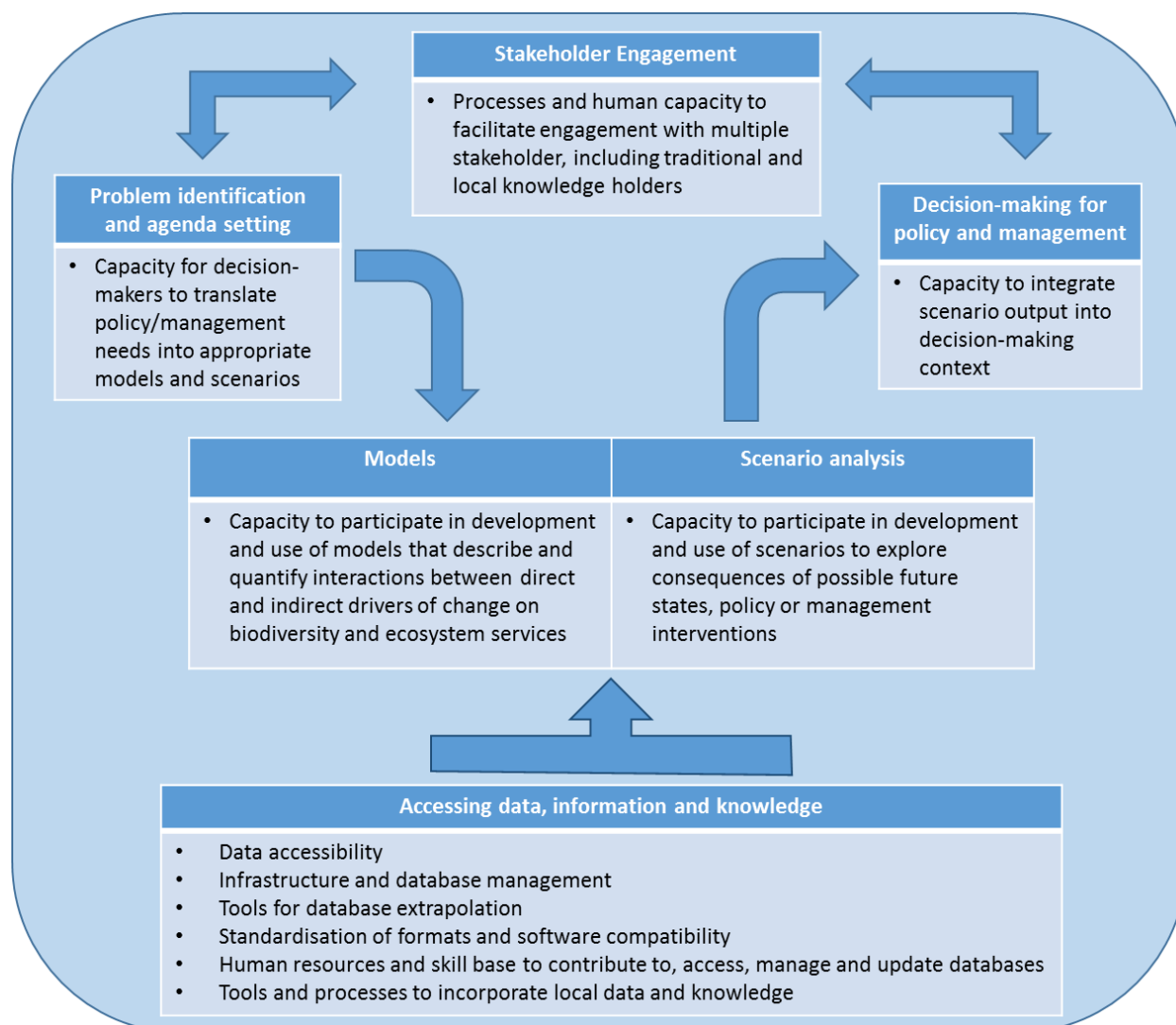

Figure 7.1: Capacity-building requirements for biodiversity and ecosystem services scenario analysis and modelling.

Table 7.1

Capacity-building objectives, strategies, actions and entry points for developing biodiversity and ecosystem services models and scenarios.

Capacity-Building Goal	Strategies	Actions and entry points
Enhance national and regional networks, individuals and team capacities to carry out scenarios exercises within IPBES assessments	<ul style="list-style-type: none"> • Establish or strengthen regional networks of experts • Update and complement knowledge and skills in scenarios • Improve research capacities of universities and other research and training institutions • Implement biodiversity and ecosystem services scenario and model training 	<ul style="list-style-type: none"> • Map current expertise/capacities (local and regional) • Identify needs • Host regular training national and regional workshops to share methodologies • Host workshops for specific technical aspects • Assist in conducting scenarios within assessments on the ground • Train new and emerging actors in applied settings • Develop curricula relating to ecosystem services and development of scenarios • Involve students and young researchers (e.g., through fellowships)
Enhance institutional expertise, particularly on the science–policy interface, for effective adoption of the scenario findings.	<ul style="list-style-type: none"> • Engage stakeholders • Enhance the science policy interface in support of implementing scenarios • Improve the shared knowledge base • Improve understanding of the decision-making process on the part of the scientific community • Improve capacity for transdisciplinary and trans-sectorial communication 	<ul style="list-style-type: none"> • Establish inclusive assessment governance structure (stakeholders, scientists, policy makers, local organisations or individuals) • Host networking and face to face meetings with multiple stakeholder groups • Promote dialogue and development of visioning exercises with multiple actors (scientists, government officials, policymakers and other stakeholders) • Promote dialogues on scenario approaches to improve the shared knowledge base (including qualitative and participatory approaches) • Train in communication skills
Strengthen institutional and organisational structures at all levels	<ul style="list-style-type: none"> • Assess, revise and develop scenarios and modelling capacities • Enhance the capacity to participate effectively in IPBES assessments • Develop capacity to locate and mobilise financial and technical resources • Establish exchange programme and technical assistance 	<ul style="list-style-type: none"> • Develop plans of actions • Establish institutional partnerships at all scales • Promote IPBES matchmaking to bring together experts, practitioners, mentors, and local knowledge holders with financial resources • Increase cooperation between centres of excellence/institutions • Create common platforms, working groups diverse knowledge holders including Indigenous Local Knowledge (ILK) holders.

Table 7.2: Capacity-building objectives, strategies, actions and entry points for enabling target groups to use biodiversity and ecosystem services models and scenarios.

Capacity-Building Goal	Strategies	Actions and entry points
Enhance decision making processes at national, regional and global levels by enabling policy makers to better use scenario outcomes	<ul style="list-style-type: none"> • Map priority areas on capacity need for users and develop tailor made courses on prioritised thematic subjects 	<ul style="list-style-type: none"> • Identify the expectations and priority areas on capacity need for users. • Develop user friendly and open access prototypes of models and scenarios • Develop simplified modules and courses on focussed thematic subjects relevant for effective decision making • Organise short and tailor made courses on prioritised thematic subjects • Evaluate relevance and effectiveness of the courses and modules and adjust periodically
Institutionalise science–policy interface in governance systems for effective adoption and use of the results from models and scenario.	<ul style="list-style-type: none"> • Encourage institutions responsible for decision making to provide opportunity to develop skill and include such expertise in the team. 	<ul style="list-style-type: none"> • Include skilled human resources having understanding on scenarios and models in science – policy interfaces • Enhance trust in models • Develop skills to interpret model robustness, how well models represent biodiversity and ecosystem services processes and reproduce observed behaviours and how sensitive they are to uncertainty • Promote multidisciplinary teams in decision making process • Provide incentives for using science-policy interface in decision making process • Promote the inclusion of use of models and scenarios throughout the policy cycle (see Chapter 2)
Strengthen science–policy interface using models and scenarios through human resources development	<ul style="list-style-type: none"> • Establish curriculum on science–policy interface using models and scenarios at different levels 	<ul style="list-style-type: none"> • Organise tailor made diploma courses for professionals engaged in decision making positions • Initiate the concept of decision-making process using models and scenarios at school curriculum.

7.1.2 Current capacity to effectively participate in the development and use of scenarios and models in IPBES assessments

Regional, sub-regional and national similarities and differences exist in people's capacity to participate in biodiversity and ecosystem services scenario analysis and modelling.

These differences are a reflection of political history, environmental variability, information and communications technology, economic capacity, population size and education, among many other factors (Rodrigues, 2010). Differences in capacity are most noticeable when comparing infrastructure to support scenario analysis and modelling across nations and regions.

Significant differences are apparent when comparing economic investment priorities by different governments, which include prioritisation of research on biodiversity and ecosystem services (Figure 7.2A). Disparities in authorship of scientific papers on biodiversity and ecosystem services models highlight cross-regional and national differences, reflecting disparities in both human and technological capacity in biodiversity and ecosystem services modelling (Figure 7.2B). Unfortunately, biodiversity-rich countries and regions are not the major contributors to biodiversity and ecosystem services modelling and scenario analysis. Additionally, there are geographic inequalities in the ability to access information about biodiversity and ecosystem services scenarios and models, and datasets and software tools used to develop them, as approximated by relative internet usage (Figure 7.2C).

Innovations in biodiversity and ecosystem services models are often supported by government funding through academic and research institutions or through direct funding by government ministries to develop and implement management solutions. However there is a dependency on external organisations (e.g., environmental non-governmental organisations) to provide technical and financial resources in many nations with smaller economies, with resulting challenges with long-term viability and uptake by local stakeholders (Morrison et al., 2010; Horigue et al., 2012; Mills et al., 2015).

There are also cultural differences at local, regional and national scales that need to be recognised for biodiversity and ecosystem services scenario planning processes. These include biases due to lack of cross-cultural engagement and understanding, and also biases where local or traditional management practices, customary and participatory decision making, and oral knowledge and data gathering are not integrated into policy and decision making. Cultural frameworks also guide taboos about types of management and decision-making frameworks that are acceptable, and methods to collect and share data. The separation of people and nature can result in discontinuities between local community priorities for biodiversity management, and those of government institutions.

Thematic biases are apparent at the ecosystem scale with biodiversity and ecosystem services models and scenarios more commonly used to support decision making in terrestrial ecosystems compared to marine and freshwater ecosystems (FRB, 2013). Socio-economic drivers also result in differing capacity across topical issues, with model capacity biased toward resource-based modelling (e.g., fisheries, forestry, agriculture) and fewer resources allocated to models that have little underlying economic gain. Increased understanding and integrating of ecosystem service concepts into environmental policy, and recognition of ecosystem services concepts in international commitments at platforms such as the Intergovernmental Panel on Climate Change (IPCC) and IPBES are resulting in models that are more integrated, and include environmental (e.g., water quality), climate (e.g., coastal inundation, sea level rise, ocean acidification) and biodiversity objectives alongside socio-economic, cultural and community objectives.

Finally, external drivers can influence the use of biodiversity and ecosystem services scenarios and modelling. Political agendas, which vary on temporal scales of political tenures, can provide impetus or hindrance for innovations and decision making, and can also bring instability by causing reversals of existing decisions and environmental commitments (e.g., Australia's 2014 decision to repeal its carbon tax, and resulting changes in institutional support for climate-related research). National and regional environmental policies often have topical biases (e.g., biases toward terrestrial over marine and aquatic policies) that drive funding, data collection, and decision making. Similarly, non-governmental organisations have research priorities that may result in biases in research agendas, e.g., focus on protected area implementation rather than sustainable agriculture or water quality.

With an understanding of historical differences and similarities in capacity for biodiversity and ecosystem services modelling and scenario analysis, future strategies for capacity-building can build on these existing capacities, and fill national and regional gaps. In the remainder of this chapter, we present strategies to develop capacity for effective participation in the development and use of scenarios and models in IPBES assessments, to access data, information and knowledge, to integrate biodiversity and ecosystem services models and scenarios into policy and decision-making frameworks, and to provide for meaningful multi-stakeholder engagement.

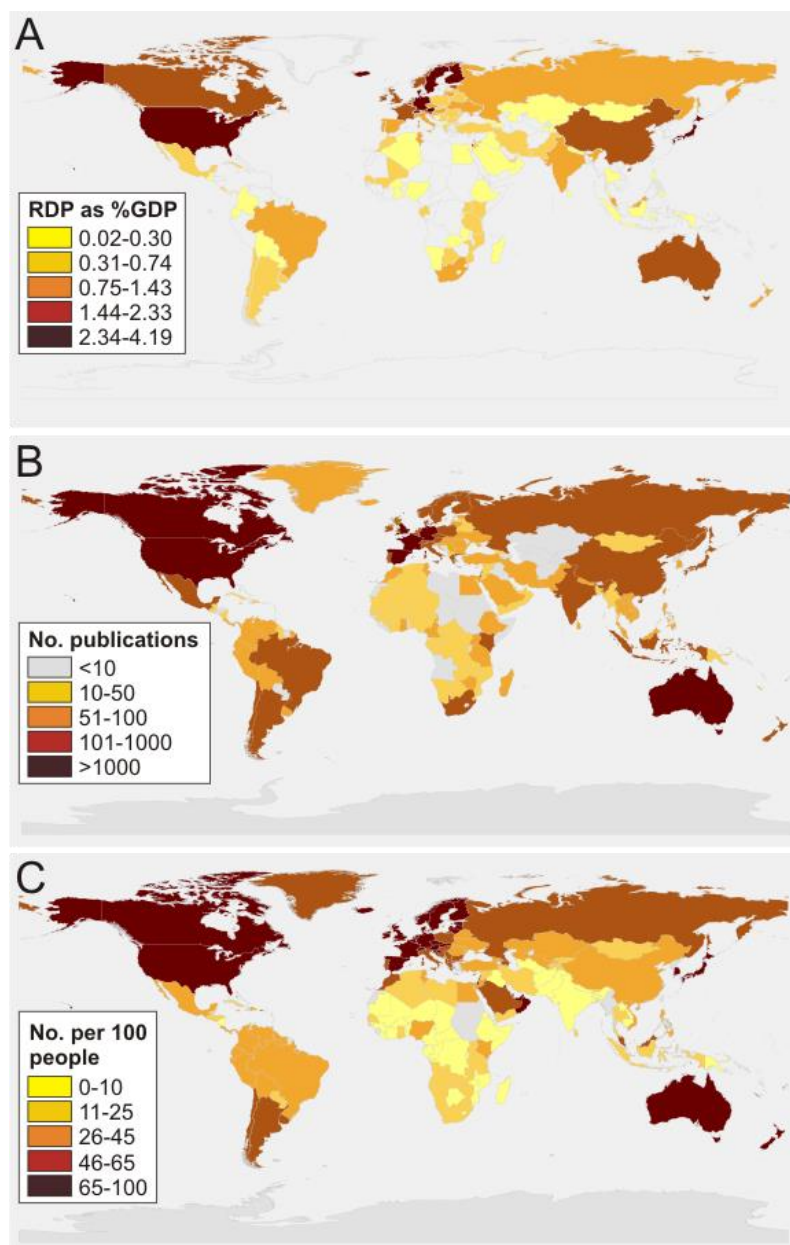

Figure 7.2. Regional differences in capacity to support biodiversity and ecosystem services modelling and scenario analysis. A. **Research and development expenditure (RDP as a % of Gross Domestic Product (GDP)).** Current and capital expenditures (both public and private) on creative work undertaken systematically to increase knowledge, including knowledge of humanity, culture, and society, and the use of knowledge for new applications. Data source: United Nations Educational, Scientific, and Cultural Organization (UNESCO) Institute for Statistics (<http://databank.worldbank.org/>); B. **Peer-reviewed publications of scientific and technical journal articles** based on search of ISI Web of Science citation database for all years (1900-current) for nationality of authors of publications with TOPIC: (ecosystem service*) OR TOPIC: (biodiversity*) AND TOPIC: (model* OR scenario*); C. **Internet users per 100 people.** Data source: World Bank/World Development Indicators (<http://databank.worldbank.org/>).

7.2 Enhancing capacity to effectively participate in the development and use of biodiversity and ecosystem services scenarios and models

It is important, including for the IPBES Work Programme, to enhance people's capacity to effectively participate in the development and use of biodiversity and ecosystem services scenarios and models (Annex 4, IPBES Task Force on Capacity-Building). Developing and using biodiversity and ecosystem services scenarios and models requires expertise in various fields such as ecological processes, modelling, economics, geographic information systems, and the social sciences to contribute to regional, global, and thematic assessments. The development of policy support tools and methodologies to integrate models and scenarios into national and regional decision-making requires the expertise of ecologists, social scientists, economists, lawyers, and policy analysts. In addition, facilitators with

experience in participatory approaches are needed to enable the incorporation of local and traditional knowledge and stakeholder input into scenarios, models, and decision-making processes.

7.2.1 Technical capacity for effective participation in models and scenarios

Key aspects of the technical capacity required for scenario analysis and modelling include improving access to, and guidelines for, user-friendly software tools for scenario analysis, modelling and decision-support systems.

There is a clear need for guidelines and documentation for recommended tools for scenario development and modelling (models, software and databases) in the six UN languages and other languages, where appropriate, using clear terminology that the users and developers of models and scenarios can understand. Developing and supporting networks, workshops and user groups for people to ask questions and interact with other users of models and scenarios, could promote knowledge exchange and development of capacity within and between regions.

Case study examples can assist in building confidence in using scenarios and models for biodiversity and ecosystem services analyses, through provision of models, software and actual datasets to allow development of skills in their use. Visualisation tools included with open-access software, such as the CommunityViz geovisualisation tools (<http://placeways.com/communityviz/>), can assist in exploring modelling software and the implications of different management scenarios. These will enable improvements in the exploration and communication of alternative scenarios, and promote more effective planning and management.

The most important aspects for successful use of biodiversity and ecosystem services models and software tools are accessibility, user-friendliness and robustness of these tools.

Models can be used individually or combined within scenario analyses to describe relationships between indirect drivers, direct drivers, and biodiversity and ecosystem services, resulting in predictions that relate to nature's benefits to people. Software used in biodiversity and ecosystem services models ranges from commercial applications such as ArcGIS and other geospatial software, to specialist tools developed specifically to model ecosystem services (e.g., Integrated Valuation of Ecosystem Services and Trade-offs (InVEST)), to applications for mobile phones, such as those created to support taxonomic identification and geospatial recording of biodiversity records (Table 7.3; reviewed in Bagstad (2013)). There are also models specifically developed to suit local or regional situations.

Intellectual property rights can influence access to both software and datasets used in biodiversity and ecosystem services models and scenarios. While many tools are open source and freely accessible, access to proprietary software can be attained through financial support from funding sources such as the United Nations, the World Bank, and the Convention on International Trade in Endangered Species (CITES). Examples of open-source biodiversity software tools include Waterworld and Co\$ting Nature (Table 7.3). Other tools such as Vensim offer versions that are free for academic use or free for a period of time or with limited functionality to allow people to begin to use these tools. Co\$ting Nature provides free web training for their user base, and includes links to most global datasets in their TerraSim server; this software also provides the option to upload other databases if there is better data available. If computing resources are limited, cloud technologies can be harnessed to allow for adequate processing power to perform models and scenarios using large datasets.

Table 7.3

Comparison of accessibility and usability of widely used software for biodiversity and ecosystem service models and scenario analysis (see also Chapter 4, Table 4.3 and Chapter 5, Table 5.4 for detail related to the use of these and similar modelling tools in biodiversity and ecosystem services models and scenario analysis).

Name	Tool Categories	Open source	Documentation and training	Additional software requirements	Data requirements
ARIES http://www.ariesonline.org/	Stakeholder engagement and outreach; Modelling and analysis; Visualisation; Decision support	Yes	Online documentation; online training via webinars; technical support as needed	No resources required to use basic functionalities (data are included, tool is web-based). Detailed analysis may require data input for region of interest if not already available.	Probabilistic and capable of operating in conditions of data scarcity. No data is required for basic analysis, but user data can be input to improve predictions.
ECOSERV http://www.durhamwildlife.org/wp-content/uploads/2012/06/EcoServ-GIS-Executive-Summary-Only-WildNET-Jan-	Modelling and analysis; Decision support	Free for Wildlife Trusts	Online documentation	ArcGIS 10 or higher software	Geospatial data

2013-9-pages.pdf					
GLOBIO3 http://www.globio.info/	Modelling and analysis; Decision support	No	Online documentation, in person training workshops	Specialist training and software required	Unspecified
INVEST http://www.naturalcapitalproject.org/	Modelling and analysis; Visualisation; Decision support	Yes	Online user guide, in person and online training and webinars, online forum for troubleshooting	ArcGIS (ArcInfo 9.3 or higher)	Biophysical data (e.g., land cover, topography, precipitation); socio-economic data (e.g., population density, property values, operating costs, market prices of natural resources).
LUCI http://www.victoria.ac.nz/sgees/research/research-groups/environmental-modelling/ecosystem-service-modelling#lucideveloping	Stakeholder engagement and outreach; Modelling and analysis; Visualisation; Decision support	No	Not currently available	ArcGIS	Geospatial data
SOLVES http://solves.cr.usgs.gov/	Stakeholder engagement and outreach; Modelling and analysis; Visualisation; Decision support	Yes	Online user guide and tutorials	ArcGIS 10, 10.1 or 10.2 software	ArcGIS supported formats for geospatial and tabular data
WATERWORLD/COSTING NATURE http://www.policysupport.org/waterworld , http://www.policysupport.org/costingnature	Data processing and management; Stakeholder engagement and outreach; Modelling and analysis; Decision support	Free for non-commercial uses	Online documentation, in person and online training	GIS skills useful but not necessary	None - all data supplied

7.2.2 Developing capacity to participate in assessments and in developing policy support tools and methodologies

Training programmes are an important part of building human capacity to support biodiversity and ecosystem services models and scenarios analysis.

Training programmes should be provided in the most widely used language in a region to support the development of biodiversity and ecosystem services skills (Paulsch et al., 2015). A selection of training programmes relevant to IPBES include those training programs associated with the United Nations Environment Programme - World Conservation Monitoring Centre (UNEP-WCMC) (www.unep-wcmc.org/expertise), the Massive Open Online Courses (MOOC <https://www.mooc-list.com/>), the Sub-Global Assessments Network (SGA) (<http://www.ecosystemassessments.net/network/mentoring-scheme.html>), and the International Union for Conservation of Nature (IUCN) Red List training (<http://www.iucnredlist.org/technical-documents/red-list-training>). These training programmes perform a wide range of activities, from coursework, student supervision and mentoring of early career scientists, to project placement and capacity-building to promote skills in the field of ecosystem assessment. The recently established IPBES Mentoring programme will also mentor early career scientists in developing skills to participate in assessments within the IPBES Work Programme.

Training is also an important component of software applications. Regular courses are run at global, regional, and national scales, including through online training and webinars, and provide guidance on use and application of different models and software tools (Table 7.3). Short-term training courses are also often held in association with meetings of scientific societies or through various regional and national projects. For example, projects such as the Climate Change Impacts on Ecosystem Services and Food Security in Eastern Africa (CHIESA) under the International Centre for Insect Physiology and Ecology (ICIPE) sponsored courses to train practitioners in some of the tools (such as InVEST) in biodiversity and ecosystem services scenario analysis and modelling. Short-term courses and workshops can also be used to provide training on a selection of key biodiversity and ecosystem services scenarios and model tools. Regular courses to support development of biodiversity and ecosystem services skills will

enhance capacity of practitioners and early career researchers, especially from developing countries, in addition to sharing of knowledge and skills and establishing networks across geographical boundaries.

The development and interpretation of scenarios requires explicit acknowledgement of the interdependencies between system components and the uncertainties associated with ecosystem driver trajectories. To be the most effective for decision makers, an understanding of the different parameters that can produce a range of possible futures is also needed. This ‘what if’ analysis (Costanza, 2000; Watson and Freeman, 2012) can be considered an extension of a sensitivity analysis, where all inputs are consistently modified against an overarching theme or narrative (Francis et al., 2011). Training in scenario analysis ideally includes detailed documentations of parameters and model inputs (if these are inbuilt in scenarios). In addition, information and training for scenario analyses are optimised when associated with the development of models and software tools.

7.2.3 Developing and utilising networks to enhance capacity to implement the use of scenarios and models

International environmental governance literature generally conceives of ‘networks’ as the links created by and through social relations in economic, cultural, and political domains, with an emphasis on the materiality of the operation and practice of these networks (Bulkeley, 2005). Using this definition to guide the development and utilisation of networks to enhance the capacity for implementing scenarios and models into the IPBES work programme can focus attention on supporting various educational and development pathways at a range of interconnected scales.

Many global programs, partnerships and initiatives provide opportunities for human resource and skills development associated with biodiversity and ecosystem services through a wide range of training courses, workshops, internships and collaborative projects. Long-term partnerships with universities in developing and developed countries can provide training of practitioners in tools and software for scenario analysis and modelling through the development of short courses and establishment of MPhil/research fellowships. For example, the Oppla network, in development through European Union (EU) funding, will provide facilities to support communities of science, policy and practice for ecosystem services and natural capital, including training courses, guidance documents, and networking opportunities.

Similarly, another way to enhance capacities to use tools is the reinforcement and support of existing regional infrastructure for modelling biodiversity and ecosystem services. Such infrastructure is already present in many places but often lacks funding for training or is not well known. By developing a relationship with the agencies and institutions that have some ecosystem services modelling capacity already, it may be possible to implement a ‘train the trainer’ programme that could exponentially enable capacities.

Creating a networks and user forums that include scientific communities, stakeholders, decision makers, and policy makers can enable feedback at all stages of model development, including evaluating scenario and model outputs with empirical observations.

Such networks and forums are useful for people to ask questions, interact with other users, and exchange knowledge. Communities of practice around specific modelling and scenario tools, such as Marxan and Ecopath with EcoSim (EwE) can build capacity in software use, serve international networks of users, and answer queries from software applications to dataset requirements related to the software.

There is also a need to build communities of practice around broader aspects of modelling and scenarios. International programs such as the Natural Capital Project

(<http://www.naturalcapitalproject.org/>) and The Economics of Ecosystems and Biodiversity (TEEB) (<http://www.teebweb.org/>) provide such networks.

7.3 Improving capacity to access data, information and knowledge

Datasets are essential contributors to our understanding of biodiversity and ecosystem services.

Biodiversity datasets were used to determine that governments missed their target to reduce the rate of biodiversity loss by 2010 (sCBD, 2010). Although the rate of loss was significantly reduced relative to potential biodiversity losses in the absence of existing conservation efforts (Hoffmann et al., 2010), progress toward 2020 Aichi biodiversity targets is limited (sCBD, 2014). These analyses were interpreted through existing datasets by utilising biodiversity and ecosystem service modelling and scenario development processes (e.g., Sala et al., 2000; Leadley et al., 2010; Pereira et al., 2010; Pereira et al., 2013). One of the many reasons for this global failure was the shortage of comprehensive indicators and associated accessible data (Butchart et al., 2010; sCBD, 2010). To create appropriate policies to protect biodiversity, understanding how humans benefit from biodiversity, how species interact, and how they might respond to changes of pressures, both natural and man-made, is essential (Mace et al., 2010; Brooks et al., 2014).

7.3.1 Develop the capacity to gain access to data, information and knowledge managed by internationally active organisations and publishers

Realising the importance of data, many global, regional and national initiatives have progressed to archive different forms of data for the use and applications on various decision-making processes (Table 7.4; MA, 2005a; Chettri et al., 2008; Yahara et al., 2014; Viciani et al., 2014). This is true even at the global level where Multilateral Environmental Agreements such as the United Nations Framework Convention on Climate Change (UNFCCC), the Convention on Biological Diversity (CBD), the Convention on Wetlands of International Importance (RAMSAR), the Convention on International Trade in Endangered Species (CITES), the United Nations Convention to Combat Desertification (UNCCD) and Millennium Development Goals are supported by a range of primary and secondary data both at national and global levels to reach common conservation and development goals. Extensive uses of global and regional datasets are also evident in the progressive and refined reporting from IPCC Fourth Assessment Report (IPCC, 2007) and IPCC Fifth Assessment Report (IPCC, 2014).

Table 7.4

Types of platforms that support model and scenario datasets

Type of platform	Scale	Examples
Multilateral environmental agreements and Biodiversity-related Conventions	Global, regional	Convention on Biological Diversity (CBD), the Convention on International Trade in Endangered Species (CITES), Convention on Migratory Species (CMS), Convention on Wetlands of International Importance especially as Waterfowl Habitat (Ramsar Convention), the United Nations Convention to Combat Desertification (UNCCD)
International Government Organisations (IGOs)	Global, regional	Food and Agriculture Organisation (FAO), Global Environment Facility (GEF), Global Biodiversity Information Facility (GBIF), International Union for Conservation of Nature (IUCN), United Nations Environment Programme (UNEP)
Regionally hosted datasets	Regional, sub-regional	Pan-European Species-directories Infrastructure (PESI), Arctic Biodiversity Data Service, ASEAN Biodiversity Information Sharing Service (BISS), European Landscape Convention, The Alpine Convention
Global thematic datasets	Global, 'thematic'	Ocean Biogeographic Information System (OBIS), MarineBio Species Database (MarineBio), the Global Invasive Species Database (GISD), BirdLife International, FishBase, HerpNET, Integrated Botanical Information System (IBIS), Integrated Taxonomic Information System (ITIS)
Others	All scales	Global Biodiversity Informatics Outlook (GBIO), World Biodiversity Database (WBD), Natura 2000, NatureServe

Parties to such conventions are obliged to develop clearing housing mechanisms with established national level accessible datasets. These practices have significantly contributed to dataset development processes and accessibility. More extensive and accessible datasets are anticipated to improve accuracy and relevance of biodiversity and ecosystem services models and the scenarios, and include the uptake of these tools into environmental assessments. Some of the promising efforts on developing global biodiversity databases include the Encyclopedia of Life (Parr et al., 2014), the IUCN Red List of Threatened Species (<http://www.iucnredlist.org/>), and Key Biodiversity Areas, through the Integrated Biodiversity Assessment Tool (Harris, 2015) and the Global Biodiversity Information Facility (GBIF) (Robertson et al., 2014; Hjørding et al., 2015) among others. The GBIF portal has made significant progress in providing access to over 500 million published digital species records, of which ~80% are geo-referenced data records worldwide (Figure 7.3). Efforts have also been made to develop thematic datasets on forests (Gilani et al., 2015; Pfeifer et al., 2014), wetlands (Lehner and Doll, 2004; Chaudhary et al., 2014), and mountain ecosystems (Chettri et al., 2008; Guralnick and Neufeld, 2005; Gurung et al., 2011).

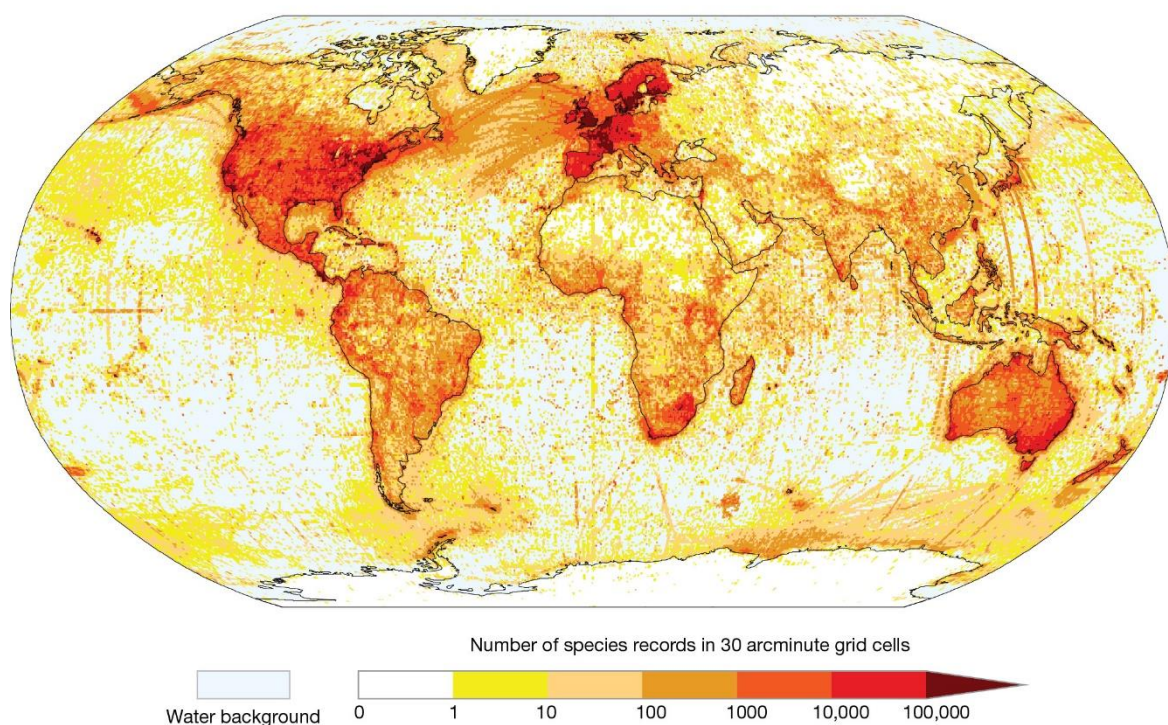

Figure 7.3: Density of geo-referenced species occurrence records published through GBIF till December 2015. Top ten contributing countries of geo-referenced data include the United States of America, Sweden, United Kingdom, Australia, Netherlands, Germany, France, Finland, Norway, and Spain) (Source: <http://www.gbif.org/occurrence>).

As new technologies and scientific approaches are evolving, modelling of both new and historical datasets can provide enhanced understanding of the role of biodiversity and ecosystem services in human health and well-being (Pimm et al., 2014). However, this can happen only if we are able to enrich, maintain and use quality data effectively (GBIF, 2013). Examples include the data quality checks to resolve issues of geo-referencing and taxonomy in many biodiversity databases. These data quality standards support data archiving in a structured and standardised form to enable a diversity of uses, creating new opportunities for research and application, and supporting biodiversity-related policy making. Integration of biodiversity and ecosystem services datasets into innovative modelling tools can enable us to understand the trends and projections with scenarios, and serve as building blocks for future conservation and development goals.

There are five broad groups of issues that are relevant to the access to and incorporation of data into biodiversity and ecosystem services models and scenarios, including intellectual property rights (Arzberger et al., 2004).

1. Technological issues: Broad access to research data, and their optimal utilisation, requires appropriately designed technological infrastructure, broad international agreement on interoperability, and effective data quality controls (Table 7.5);
2. Institutional and managerial issues: While the core open access principle applies to all science communities, the diversity of the scientific enterprise suggests that a variety of institutional models, intellectual property rights, and tailored data management approaches are most effective in meeting the needs of researchers;
3. Financial and budgetary issues: Scientific data infrastructure requires continued, and dedicated, budgetary planning and appropriate financial support. The use of research data cannot be maximised if access, management, and preservation costs are an add-on or after-thought in research projects;
4. Legal and policy issues: National laws and international agreements directly affect data access and sharing practices, despite the fact that they are often adopted without due consideration of the impact on the sharing of publicly funded research data or on intellectual property rights;
5. Cultural and behavioural issues: Appropriate reward structures are a necessary component for promoting data access and sharing practices. These apply to those who produce and those who manage research data.

Table 7.5

Technical requirements to improve data quality and compatibility

Issue	Specific technical requirements
Data quality	<ul style="list-style-type: none"> • Documentation of uncertainties surrounding data collection and measurement error • Authenticity and integrity of data source • Security against loss, destruction, modification, and unauthorised access • Taxonomic resolution and revision (e.g., Nativi et al., 2009). • Inter-operability across the temporal and geospatial scales (e.g., Edwards et al., 2000)
Data format	<ul style="list-style-type: none"> • Compatibility with multiple analytical, reporting and publishing options • Compatibility for both spatial and temporal analysis as well as with available software • Geospatial grids and projections appropriate to geographic region and scale, including altitude • Use of commonly of recognised and widely used data standards such as Darwin core (e.g., Wieczorek et al., 2012)
Data inter-operability	<ul style="list-style-type: none"> • Compatibility of technical standards and protocols across software packages and data management organisations to ensure the access and usability of data
Accessibility	<ul style="list-style-type: none"> • Open access to data and software • Ability to combine data from multiple sources • Comprehensive documentation of datasets
Flexibility	<ul style="list-style-type: none"> • Flexibility to incorporate data management innovations • Flexibility to integrate across disciplines, scales and ecosystems
Long-term sustainability	<ul style="list-style-type: none"> • Financial sustainability to maintain infrastructure including publishing platforms and data hubs • Technological backups of both data and platforms

7.3.2 Developing capacity to enhance multi-disciplinary and cross-sectoral collaboration at the national and regional levels

Existing data collection and management practices could be improved with emphasis on data quality, inter-operability, and institutionalisation of data management processes through short- and long-term strategies.

Data collection and management are among the least priority areas leading to limited representation or participation in global database development discourse. The vast information available amongst the traditional and indigenous people and their fading knowledge has not been properly documented and archived. Many of the existing global datasets, such as the datasets for temperature, and forest for Global Circular Models or the History Database of the Global Environment (HYDE) (Klein Goldewijk et al., 2011), are with coarse resolution. They do not capture the fine-scaled picture of varied landscapes such as that of mountains or small sized wetlands and fragmented forests (Sharma et al., 2010; Pfeifer et al., 2014; Svob et al., 2014).

The existing datasets maintained by Secretariats of multilateral agreements such as UNFCCC, CBD, RAMSAR, the global commons on bioinformatics such as GBIF and IUCN Red List, and other datasets maintained by developed countries do not show complementarity to each other and duplication of work is prominent. Geospatial datasets for the same location may use different geospatial projections, making datasets incompatible (e.g., the numerous geospatial projections available for the Antarctic region, and lack of consistency in usage for Antarctic datasets). In addition, taxonomic inconsistencies, provision for inter-operability among the existing datasets, and duplication of efforts in generating datasets and developing database infrastructure among the biodiversity research communities are bringing more complexities in database management domain rather than contributing to its resolution.

The openABM project (openABM.org) provides a useful example of a general model database for biodiversity and ecosystem services models and scenarios. The Centre for International Earth Science Information Network (CIESIN) have assembled multiple datasets to make it easier for modellers to find data. Improving the accessibility, interconnection, and metadata of data related to ecosystem service models and scenarios can increase the ease with which models can be created.

A number of capacity-building strategies can result in increased capacity to use geospatial databases and analytical and visualisation tools for rapid production and access of information products (Table 7.6).

Table 7.6

Short- and long-term strategies to address gaps in data collection and management strategies to support biodiversity and ecosystem services modelling.

Short-term strategies (1-2 years)	Long-term strategies (3-20 years)
Incorporate SWOT (strengths, weaknesses, opportunities and threats) analysis	Establish/improve data base infrastructures (portals) and accessibility
Prepare database development and management outlook at national and regional levels	Strengthen regional network and cooperation (particularly in nations without culture of data sharing)
Develop database catalogue and identification of gaps	Establish global and regional advisory platforms to certify the quality of the datasets in conformity with the adopted standards
Provide thematic modules for capacity development (training resources available online)	Link results with policy development process
Provide training for database developers and users	Ensure mechanisms exist such that datasets are updated when new information is available
Promote data sharing and users policies	Ensure financial sustainability
Develop guidelines for habitat assessment to allow approximation of ecosystem services based on land-cover/biotypes, and guide data collection to validate model functional relationships	Develop priorities to enlarge data coverage of global datasets
Develop tools for down-scaling of common databases (e.g., GBIF, climate models)	
Develop queries to enable dataset transformations of popular global indices to seasonal-monthly-daily scales; spatial queries to enable regional, national or local scale analysis of global datasets	
Develop products using new technologies such as Android and iOS applications (e.g., Aichi Indicators Exploration application) and E-books (e.g., E-Handbook of the Convention on Biological Diversity) to communicate information from IPBES	

7.4 Integrating scenarios and models into policy and decision making

7.4.1 Capacities required to integrate biodiversity and ecosystem services models and scenarios into policy and decision-making

A scenario provides a basis that allows decision units (governments, agencies) to reflect on how changes in developments beyond their immediate spheres of influence, i.e., biodiversity and ecosystem services, may affect their decisions. Effective scenario building and model construction require expertise in several fields including management, development, ecology (terrestrial or marine), climate change, culture, agriculture, economics and mapping, among others, depending on the subject at hand (McKenzie et al., 2012).

Chapter 2 identifies the primary impediments to the widespread use of models and scenarios in decision making as: a lack of trust in modellers, models and scenarios; a lack of understanding and technical knowledge among decision makers to allow them to understand outputs and appreciate the positive role that models and scenarios can play; a lack of decision support, modelling and scenario analysis skills relative to the number of policy design and implementation challenges; a lack of willingness on the part of some modellers to engage fully in real-world decision problem and develop and communicate in a non-technical way; a lack of willingness of modellers to engage in participatory processes involving other knowledge traditions; and a lack of transparency in approaches to modelling and scenario development.

Capacity-building for decision-making about biodiversity and ecosystem services scenarios and models requires strengthening or developing long-term relevant trans-disciplinary expertise, institutions, and organisational structures to carry out scenario exercises and develop and use models within IPBES assessments (Ash et al., 2010). This capacity allows decision makers to act on findings of biodiversity and ecosystem services models. The purpose of using scenarios and developing stories is to encourage decision makers to consider certain positive and negative implications of different development trajectories (MA, 2005a). Strategies for mainstreaming scenarios and models into decision-making processes across scales (national, regional, global), and across different policy, planning and management contexts within the framework of IPBES are summarised in Table 7.1 and Table 7.2.

The key steps to mainstream scenarios and modelling into Science-Policy interface may involve:

- (1) Engaging the policy makers and all other stakeholders from the beginning;
- (2) Developing relevant biodiversity and ecosystem services scenarios and models that are easily understandable;
- (3) Translating results into policy makers' and stakeholders' language;
- (4) Using just 'sufficient' data (not too much) to convey a clear message;
- (5) Using precise and credible information for biodiversity and ecosystem services scenarios and models.

7.4.2 Strategies to mainstream scenarios into the science-policy interface

At the national scale, most governments recognise the social role of ecosystems and their biodiversity due to their influence on human health and quality of life, apart from their contribution to social and economic development through the supply of essential ecosystem services. This emphasises the socio-cultural and economic value of ecosystem services and the importance of their inclusion in policies. As an example, the failure to meet the 2010 biodiversity targets (sCBD, 2010) stimulated a set of new future targets for 2020 (the Aichi biodiversity targets). As highlighted by Perrings et al. (2011), the first strategic goal to meet the 2020 targets is to 'address underlying causes of biodiversity loss by mainstreaming biodiversity across government and society'. The Millennium Ecosystem Assessment (MA) has shown that there is no clear institutional response to address these underlying causes (indirect drivers of change), and new sets of responses are necessary to meet the 2020 targets. This requires structural changes to recognise biodiversity as a global public service as well as to integrate biodiversity conservation into policies and decision frameworks (Rands et al., 2010) at local, regional and national scales. Biodiversity and ecosystem services scenarios and models can help to fill this gap, but presently, there are very few scenarios that focus on biodiversity and ecosystem services and suit for purpose of policy and decision makers. Costanza et al. (2015) reviewed various scenarios at a global and national scale (i.e., Australia) and most of the scenarios were related to businesses or economy, not to biodiversity and ecosystem services.

The current accelerated changes in economic, social and environmental aspects require flexible policies. Policy is subject not only to a political process but also to urgent or sudden calls for decisions, before any scientific result is available (Scheraga et al., 2003). The complexity of ecosystems and their services demands reliable data and analysis for policy decisions (UNEP, 2012) (Figure 7.4). In addition, there is a growing need for scientific knowledge that is understandable across diverse stakeholder groups.

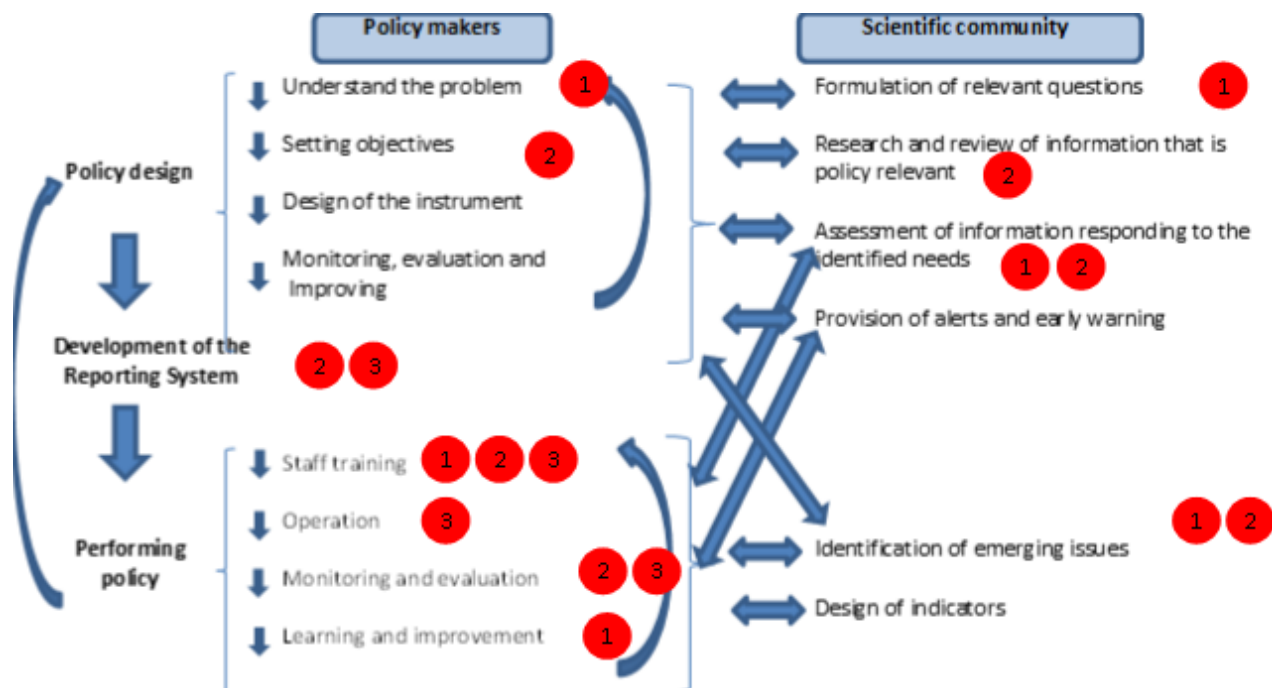

Figure 7.4: Linkages between policy makers and scientific community and the need for capacity on scenario analysis (red circles indicate Capacity-Building objectives as referenced in Table 7.1) (Source: Adapted from Swanson and Bhadwal (2009); IUCN, 2010).

There are at least two different ways in which scenarios and models could be useful for mainstreaming biodiversity and ecosystem services into policy at several scales of decision-making:

- ‘Scenarios based on models’ could be developed to project possible futures where there is a greater degree of certainty in data. For example, population models could be used to develop scenarios on the use of ecosystem services in a particular region.
- ‘Models based on scenarios’ could be used to project possible future options. A model can use different scenarios to suggest different options that may occur in the future. For example, a model can suggest the difference in values of ecosystem services over time based upon current use of ecosystem services as the scenarios based models used in the United Kingdom (Haines-Young et al., 2014).

Either of the two methods mentioned above can be applied to project long-term impacts for future decision making. However, the second approach could be more appropriate in relation to biodiversity and ecosystem services assessment given the intangible nature of many ecosystem services as well as uncertainty in biodiversity and ecosystem services data. The experts, locals and other stakeholders can apply their common judgment to predict future alternatives.

To mainstream scenarios and models into policy and decision-making, it can be valuable to include people’s well-being, economy and status and trends in biodiversity and ecosystem services as important domains in any biodiversity and ecosystem services scenario, to appropriately dialogue with policy makers. An example of a possible ‘biodiversity and ecosystem services approach’ is presented below (Figure 7.5.):

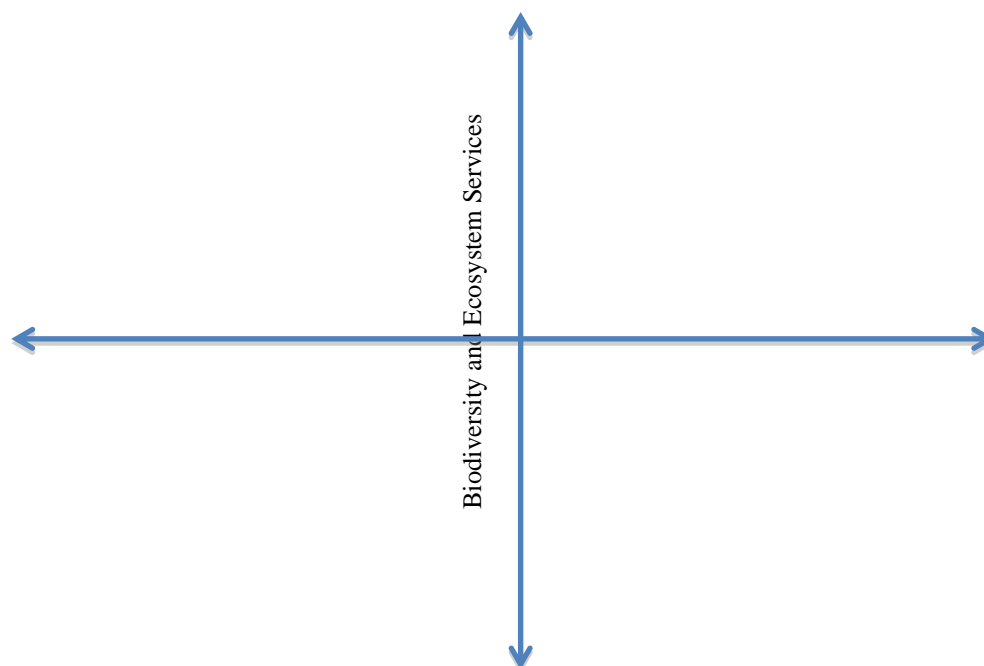

Figure 7.5: Example of biodiversity and ecosystem services scenarios on linking biodiversity and ecosystem services with economy (focused on Gross Domestic Product (GDP)) and well-being of people (adapted from Sangha et al. (2014)). Benefits to biodiversity and ecosystem services increase on the vertical access from bottom to top; benefits to the economy increase on the horizontal access from left to right.

Each type of scenario mentioned in Figure 7.5 can further include studying the impacts of change in biodiversity and ecosystem services over a long-term on: i) Government (development and policy sector); ii) Natural resources (capital) and iii) Social values (capital)

A combined approach of scenario planning and modelling can be useful for the policy decision makers to comprehend various values and changes that may occur in the benefits to humans from biodiversity and ecosystem services over the long-term. However, it is important when working with local or indigenous communities to develop scenarios that suit people's values. This is one major difference from the modelling approach where pre-developed models are applied without including local values. Scenarios can help us exploring options from local perspectives, and can accommodate local knowledge about benefits of biodiversity. This may prove very useful for IPBES assessments to demonstrate the role of ecosystem services in people's well-being, beyond the tangible measures and can significantly help to bridge the gap between local knowledge and policy decision making.

7.4.3 Recognition of the interdependence of knowledge systems, including traditional knowledge, to inform biodiversity and ecosystem services models and scenarios

'Traditional and local knowledge' refers to knowledge and 'know-how' accumulated by [regional, indigenous](#) or local [communities](#) over generations that guide human societies in their interactions with their environment (IPBES/2/17, <http://ipbes.net/>). The IPBES Conceptual Framework clearly recognises the importance and interdependence of the knowledge across multiple systems (local, scientific, technical, educational and traditional) (IPBES/2/17, <http://ipbes.net/>), and that understanding of these complex knowledge systems is necessary to determine system feedbacks within modelling and scenarios. Folke et al. (2002) and Tengö et al. (2012) highlighted the importance of such knowledge systems to build resilience in a world of uncertainties.

Traditional and local knowledge offers us a vision of the world from different knowledge systems, which provides a new perspective to define relationship between people and the environment and to construct 'another possible world' (Leff, 2011). Cultural understanding to develop scenarios or models (a common vision established in the UN Strategic Plan for Biodiversity 2011 - 2020) is a critical aspect of scenario analysis and modelling. For indigenous and local communities, environmental management decisions are intrinsically tied to culture and way of life, and their knowledge can enrich and inform scenarios and models (Feinsinger, 2001). However, these systems are often quite complex due to multiple interactions between people and their environment. The main problem of such complex systems is limited skills to understand, to predict and to control socio-ecological systems (Pilkey and Pilkey-Jarvis, 2007; Roe and Baker, 2007; Eddy et al., 2014). There is a need to develop an integrated system of conventional scientific and traditional knowledge, and for this, decision making must engage with the most relevant users (Cortner, 1999; Bocking, 2004; MA, 2005b; MA, 2005a).

Biodiversity and ecosystem services scenarios and models must integrate key aspects of local knowledge, including feedbacks between different scales and knowledge systems.

Co-design and co-production of necessary knowledge in the process of modelling and building scenarios will strengthen human capacities. To develop effective biodiversity and ecosystem services scenarios and models for decision making, diverse forms of local knowledge must come together by transcending spatial and temporal scales. The dialogue of knowledge can form the platform for scenarios and modelling, across the science exchange to strengthen the validation and the co-production of knowledge (Figure 7.6). This dialogue can integrate knowledge and world views from local and indigenous perspectives, including civil society, scientific experts, private and economic sectors, and the government. In this process, knowledge is achieved through a combination of rights, obligations and responsibilities, resulting in integral, just and sustainable management of resources (Pacheco, 2013).

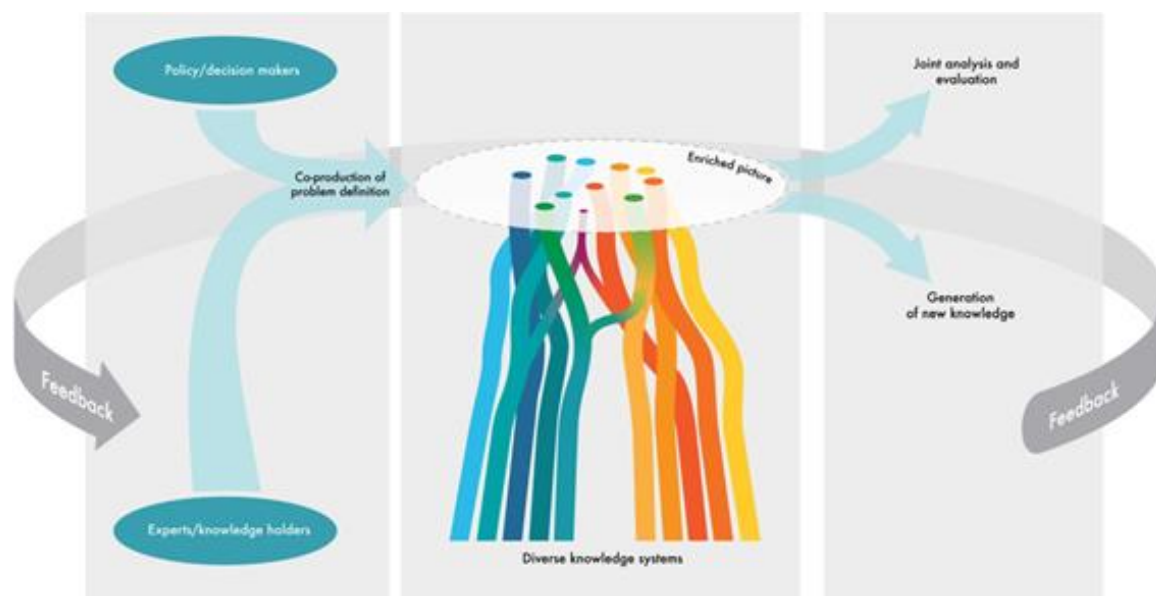

Figure 7.6: Conceptual diagram on integration of local knowledge for developing biodiversity and ecosystem services scenarios and models for decision making (Tengö et al., 2014).

7.4.4 Mechanisms to include indigenous and local knowledge in scenario analysis and modelling

To incorporate traditional knowledge systems into scenario analysis and modelling, the key mechanisms are to integrate knowledge, and enhance participation and dialogue between actors at national and regional scales.

Some key aspects to develop efficient mechanisms on integrating traditional knowledge into biodiversity and ecosystem services scenarios and models are:

1. To develop a good understanding of indigenous knowledge systems and the ability to translate and integrate this knowledge, where possible, into conventional knowledge systems
2. To study beyond the set boundaries to embrace the holistic perspectives of living that are embedded in many indigenous knowledge systems, especially for practitioners in conventional (academic) knowledge systems
3. To develop a 'common' (integrated) knowledge base through shared traditional and conventional knowledge systems (e.g., a set of indicators)
4. To apply a trans-disciplinary approach on the role of biodiversity and ecosystem services in terms of people's livelihoods (well-being), where Millennium Ecosystem Assessment (MA) framework could be useful (but with local modifications)
5. To 'effectively' engage with the local and traditional societies from the earliest possible stages of scenario and model development

Some examples of integration mechanisms include adaptive co-management, participation and ongoing collaboration with traditional and local societies (Folke et al., 2002). Adaptive co-management incorporates traditional and conventional scientific knowledge, and encourages participation and collaboration amongst all the stakeholders (Paulsch et al., 2015). It is critical to effectively engage with local and indigenous communities and their knowledge from the first stage of planning scenarios in order to allow co-definition of the problem, to increase trust and understanding between participatory stakeholders, and to reduce uncertainty in the scenarios (Peterson et al., 2003). The long-term success of a particular scenario will depend on cooperation among various stakeholders through scenario refinement, testing and iterations, to ensure acceptance for evaluating policies and informing decision making. Effective engagement with traditional and local societies can be a key to develop appropriate biodiversity and

ecosystem services scenarios.

Incorporation of traditional knowledge is a process that goes hand in hand with empowerment and strengthening of local communities, and is directly related to Aichi biodiversity target 19. One method to incorporate traditional knowledge is to develop an integrated set of biodiversity and ecosystem services indicators that are based on scientific and traditional knowledge. At a local scale, indicators that include or have links to local and regional traditional knowledge systems will better contribute to collaborative involvement and to enhance socio-ecological scenarios and models (IUCN, 2006). Robb et al. (2014) found that implementation of locally based indicators into biocultural conservation can be used to integrate local Māori knowledge and the conventional academic science. Other such example is the SESELP Program of Biocultural Subantarctica Conservation conducted at a local scale, and National Program of Conservation and Sustainable Utilization (PNCASL) for the caiman (*Caiman yacare*) in Bolivia, as presented in Box 7.1.

Box 7.1. Incorporation of local knowledge in the management and conservation of *Caiman yacare* (a crocodile species) in Bolivia

Bolivia developed a National Program of Conservation and Sustainable Utilization (PNCASL) for the caiman (*Caiman yacare*). Initially, the annual assignment of local harvest quota was estimated across the ‘Scientific Authority’ based on random counts of relative abundance. With the increasing interest among local communities to be a part in the PNCASL, a need to strengthen the system was identified for incorporating new indicators. These included both biological indicators (based upon models of the species) as well as socioeconomic and cultural indicators of species health. One of the first trials under this new approach was done in the Indigenous Territory and National Park Isiboro Séure (TIPNIS) where local knowledge was initially the most reliable source on the status of *Caiman yacare*. The quantitative indicators moved beyond quantitative measures to include qualitative indicators such as perceptions of increase in abundance of charismatic species, e.g., ‘there are a lot more caiman than before’. This helped to develop robust indicators on estimation of population size. This was achieved as the traditional resource users participated in workshops where they informed resource quotas using traditional knowledge of caiman, defining concepts, harmonising criteria, and defining the space and territory conceptualised across maps and knowledge of habitats where caiman live. From a scientific perspective, a population count was measured by the researchers involving indigenous techniques suggested by the communities. The process was repeated by the communities after an integration of knowledge systems and harvest estimates were developed based on local knowledge fortified with scientific concepts and criteria that were internalised (e.g., sizes of hunt allowed). These estimates were used to determine and manage abundance of caiman within the whole protected area. This participatory experience informed a national scale predictive model of abundance of *Caiman yacare*.

Another way to integrate indigenous knowledge for biodiversity and ecosystem services scenarios and models is to understand and evaluate the role of biodiversity and ecosystem services in people’s well-being that further links well with the science of economics. For this, there is need to develop and apply a holistic perspective of well-being for incorporating ecosystem services. Sangha et al. (2011) evaluated the role of ecosystem services from tropical rainforests in indigenous well-being in North Queensland, applying the Millennium Ecosystem Assessment (MA) approach (Figure 7.7). Each ecosystem service-well-being link highlighted the importance of an ecosystem services in terms of well-being of indigenous people that could be used in developing scenarios and models.

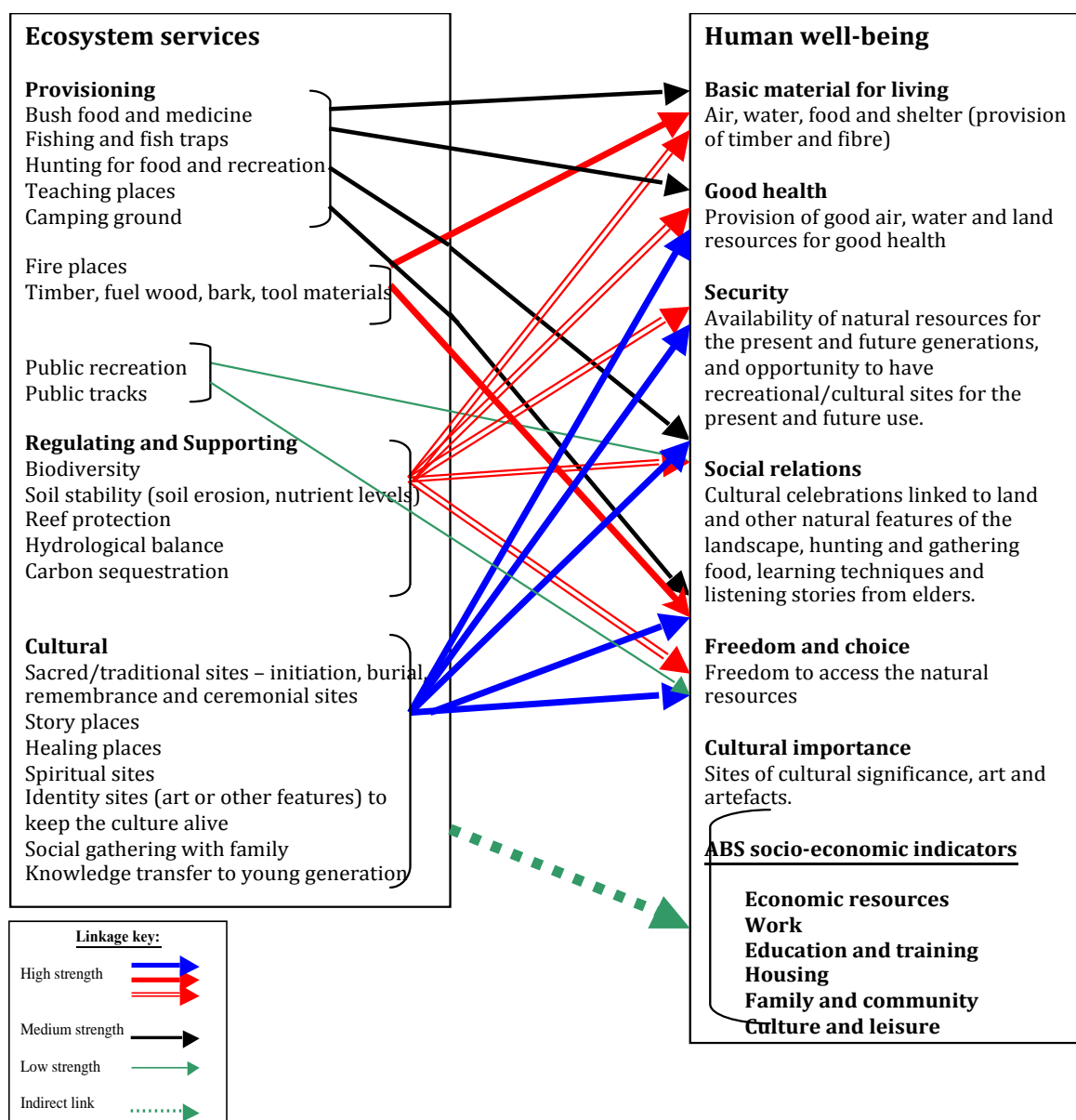

Figure 7.7: Relationships between ecosystem services and the constituents of well-being identified by the Mullunburra-Yidinji community, north Queensland (Sangha et al., 2011).

Indigenous knowledge of biodiversity and ecosystem services also links well with people's capabilities that are important when discussing people's development from a policy decision-making perspective. For example, knowledge of bush food and medicine from local plants benefits people's health and enables them to develop a capability to pass on this knowledge to the next generation. As Sen (1999) suggested, enhancing people's capabilities (e.g., health, education) will enhance their well-being. This approach, linking biodiversity and ecosystem services with indigenous capabilities, requires a new perspective of thinking about development, economics of indigenous systems and related policies. Integration (co-perception) of knowledge from conventional and indigenous systems can help to consider the importance of biodiversity and ecosystem services for policy development decisions. For example, Sangha et al. (2014) proposed an integrated well-being framework (Figure 7.8) focusing on country, which is the indigenous perception of land systems in Australia, that equates to ecosystems. The framework links and equates various ecosystem services from country (ecosystems) with the economic, cultural and social worlds of people. Such an integrated framework could be used as a tool to develop possible scenarios and models to suggest and analyse the role of biodiversity and ecosystem services in the economic and social living of indigenous and local communities.

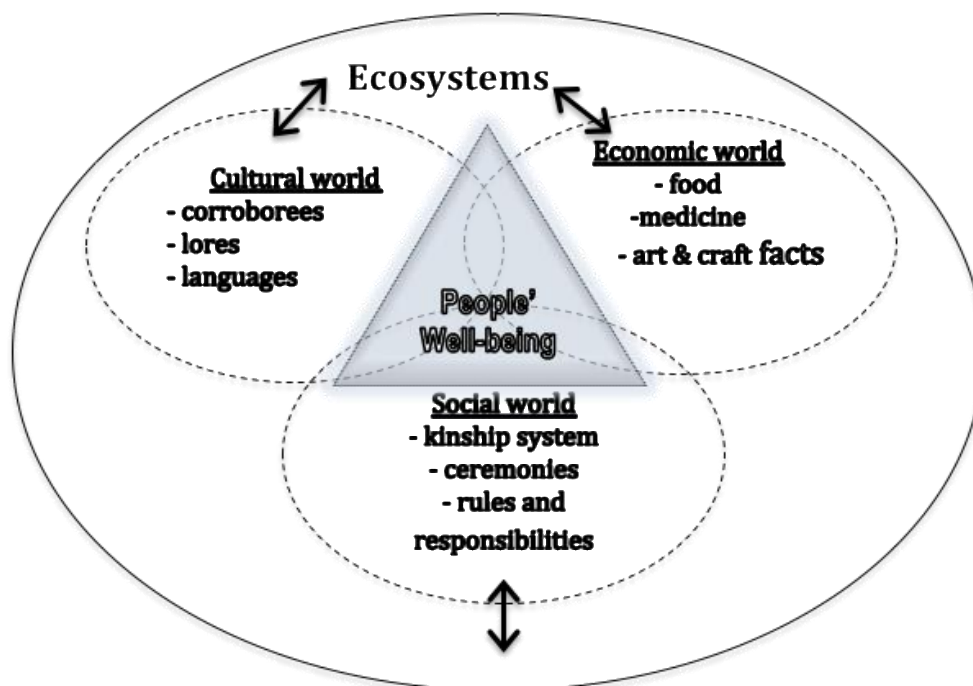

Figure 7.8: A proposed framework on how the ecosystems (i.e., country in indigenous value system) deliver various ecosystem services (in the form of social, economic and cultural values) that are vital for indigenous well-being (Sangha et al., 2014)

To support integration of traditional knowledge, people's capacities need to be identified through key stakeholders, their interests and powers, and feasibility of key stakeholders to participate in the development of relevant and inclusive biodiversity and ecosystem services scenarios and models (Table 7.1; CONDESAN and UMBROL, 2014). By incorporating traditional knowledge, the biodiversity and ecosystem services scenarios and models can actually broaden the horizon, and strengthen our current knowledge systems.

7.5 Develop the capacity for enhanced and meaningful multi-stakeholder engagement

For indigenous and local communities across the globe, scenarios can prove to be useful tools, as these can encompass indigenous and local perspectives of natural systems from a much broader perspective rather than just the biophysical or the economic perspectives that is commonly used in many models. Combining scenarios with modelling can also be an effective tool for decision makers for providing a long-term vision to support decisions. For example, each of the scenarios as mentioned in Figure 7.5 could be further processed using InVEST or any other such model, to project the outcomes over the long-term in the future.

7.5.1 Develop the capacity for effective engagement of stakeholders in assessment and other related activities at the national

A wide range of qualitative and quantitative participatory methods are available to facilitate engagement of stakeholders in scenario development.

These include but are not restricted to: workshops; scenario-based stakeholder engagement; focus group meetings, questionnaire surveys, facilitated discussion and ranking; cooperative discourse; multi-criteria evaluation; conceptual system modelling; and dynamic systems modelling (Bousquet et al., 2002; Madlener et al., 2007; Magnuszewski et al., 2005; Kowalski et al., 2009; van den Belt, 2004; Castella et al., 2005; Renn, 2006; Tompkins et al., 2008 and others).

The key steps to facilitate effective stakeholder participation in scenario development (Reed et al., 2013) are:

1. Define context (biophysical, socio-economic and political) and establish a basis for stakeholder engagement in scenario development.
2. Systematically identify and engage relevant stakeholders in the process.
3. Define clear objectives for scenario development including spatial and temporal boundaries.
4. Select relevant participatory methods for scenario development.

Capacities required to involve stakeholders, the kind of stakeholders and their levels of engagement are summarised in Table 7.7.

Table 7.7

Capacities required to engage with stakeholders and levels of involvement to integrate knowledge for scenario analysis and modelling

Level	Involved	Capacities
Local stakeholders and organisations	Local stakeholders, national and regional organisations	Representation Leadership Inclusion of biodiversity use and values into policy decision making Adaptability to ecosystem and functional change Knowledge register Information from peoples' systems of life Feedback on indicators of direct drivers Lessons learned Integration of traditional and local knowledge Procedures and legal instruments for biodiversity value and conservation
Institutions	Public and private regional associations	Transparency and credibility Measurement of indicators of indirect and direct drivers Interaction with local communities Organisational support for biodiversity and ecosystem services Transverse incorporation of biodiversity knowledge in the educational system Generation of traditional indicators in the form of Ecosystem Data Groups Exchange of information among Data Groups at regional level
Practice	Inter-scientific community; Associations that work with local stakeholders	Active participation Measurement across qualitative and quantitative indicators in relation to the direct drivers Technical integration and multilevel linkages Recapitulation of lessons learned on managing and conservation Inter-scientific dialogue Establish and support networks on biodiversity and ecosystem services

Learning occurs in both directions, with enhanced understanding of local stakeholders in regional, national and international policy and management goals, in addition to the incorporation of local knowledge into local, national and regional collaborative processes that support sustainable development and biocultural conservation. This requires collaborative dialogues between the stakeholders and decision makers (Rozi et al. 2010). Educational initiatives are valuable outlets for enhancing partnerships between the scientific community and local communities through universities and school centres.

7.5.2 Developing capacity for effective communication of the importance of biodiversity and ecosystem

Communication is crucial in dissemination of results of a scenario and modelling exercise.

This requires clear communication goals for the target audiences through appropriate means of communication. A lack of communication in real time could be a main barrier for effective participation of the local communities which influences the dialogue between communities and decision-makers (Primack et al., 2001). The spread of knowledge is greatly important for the local actors to take suitable decisions regarding the management as part of the process of empowerment. Scientific research is more likely to be applied when there is an open dialogue between different parties (Mauser et al., 2013).

Building confidence and trust in models and modelled outputs is a challenge for developing and using biodiversity and ecosystem services models and scenarios, and communication with local communities, stakeholder, and industry can increase confidence in models and scenarios through enhancing understanding of uncertainties in models. Complex dynamic models that simulate future ecosystem response are often those which many have the least confidence in. Assessment and evaluation of model robustness and performance is therefore essential, as is estimating the effect of input datasets and uncertainty in model parameters on modelled outputs.

7.5.3 Develop the capacity to effectively use IPBES deliverables in implementing national obligations under biodiversity-related multilateral environmental agreements

To enable communication of biodiversity and ecosystem services scenarios and models, they must be freely accessible, and translated into products that are compatible with both local language and scientific knowledge systems.

The co-dissemination of the results may include publication of the acquired knowledge also in accessible language, and translation into comprehensible and usable information for different stakeholders. This sharing of knowledge leads to open discussion and future research actions to target sustainability, which will then jointly be framed and initiate a new trans-disciplinary research cycle (Mauser et al., 2013). A number of communication sources are available such as graphical pamphlets, television and print media, educational systems, and internet and social media. Choice of communication media will depend on the community of interest and their technical capacity. The communication materials must have key messages and presentation format that is of relevance to local communities (e.g., local language, drawings and printing, characters, etc.), avoiding excessive technical information. For example, if one seeks to register data on a species from a local perspective, the graphical material could link this with the needs of the local people using agricultural calendars or cultural events. Highlighting the importance of a particular species in people's living based upon their current values and usages can also help to engage and communicate with the locals for future scenarios. An important part of information dissemination is that it should reach the different sectors including minorities, children, women, and aging populations.

7.5.4 Develop the capacity to strengthen networks and information sharing among different knowledge systems, including those of indigenous and local peoples

Long-term support for collaborative partnerships is important to ensure long-term survival of traditional methods of managing common property resources and integration of traditional knowledge into management decisions (Merino and Robson 2006).

Global partnerships include organisations such as the Group on Earth Observations Biodiversity Observation Network (GEO BON) which coordinates activities relating to the Societal Benefit Area, Biodiversity of the Global Earth Observation System of Systems (GEOSS), and the UNESCO Sacred Natural Sites program. Similarly, the United Nations Environment Programme (UNEP) Sub-Global Assessment network strengthens the regional and global networks among the scientists. Most existing networks are for model practitioners, the scientists and policy makers developing and implementing the models and scenarios. However, there are few existing networks for the local and indigenous communities. Similar networks need to be supported for indigenous and local communities at the local, regional and global scales and IPBES can stimulate such a platform.

7.6 Consolidation, strategy, recommendations

Based on the capacity-building requirements identified for biodiversity and ecosystem services models and scenario analysis, the following broad recommendations are proposed that would improve the use and application of biodiversity and ecosystem services models and scenario analyses:

7.6.1 Closing capacity gaps for biodiversity and ecosystem services regional scenarios and models

IPBES could:

- Produce manuals and guidelines to improve common data users' understanding, possible methodologies and limitations of scenarios and models of biodiversity and ecosystem services which are adapted to the situation and capacities of the different UN regions.
- Develop brochures and booklets about scenarios and models of biodiversity and ecosystem services which are adapted to the different user groups and, as such, enable them to tailor and package their scenarios and models in ways that are more useful for decision makers.
- Establish international forums for scenarios and models of biodiversity and ecosystem services managed by highly qualified experts that have the needed skills to translate science concepts into those that users understand and can use, without distorting the concepts. These forums will serve as tools for people to ask questions and interact with other users of models and scenarios, to promote knowledge exchange and development of capacity within and between regions. The experts, who will manage these forums, should be equally chosen to represent the different UN regions that allow them to have in depth understanding of users' needs and the potential opportunities for developing scenarios and models of biodiversity and ecosystem services in their regions.
- Use the lessons learned from previous global and regional assessments to define the other critical skills and expertise required to develop more integrated scenarios and models of biodiversity and ecosystem services in an effective way that will support decision makers.

7.6.2 Develop the capacity for effective participation in the IPBES assessments

IPBES could:

- Develop global, regional and national lists of open source and freely accessible software and tools (e.g., Deliverable 3d) that will support the development of successful scenarios and modelling of biodiversity and ecosystem services. All tools (model, software and database) should be well documented, in an intelligible language so that the user base can understand. Metadata associated with models should be written following international standards, fully illustrated and intelligible by both specialists and non-specialists.

- Run and maintain regular in person and/or online courses at global and at regional/national scales, providing training on use and application of different models and software tools.
- Use and build upon the upcoming global, regional and sub-regional assessments to establish networks of mentoring schemes for early career scientists and researchers. This scheme will seek to facilitate the establishment of mentoring relationships between early-career scientists and researchers working in the field of ecosystem assessments/services, and established assessment practitioners, in order to promote capacity development for undertaking and using current or upcoming ecosystem assessments.
- Develop global and regional ‘fellows programs’ for young scientists on integrated scenarios and models of biodiversity and ecosystem services to transfer the gained experience to the national levels.
- Build partnerships between the IPBES Task Force on Capacity-Building and other global programmes and initiatives to provide a wide range of training courses, workshops, internships and collaborative projects with universities in developing and developed countries to train practitioners on tools and software for scenario development and modelling.
- Provide funds, in cooperation with other international and regional donors, to strengthen national institutions and infrastructure on biodiversity modelling and scenario usage through multidisciplinary research, activities, planning and budgeting.

7.6.3 Promote a dialogue between different world views and knowledge systems

IPBES could:

- Encourage participation and contributions to the existing global scenarios, modelling, and database infrastructure to enhance their capacities instead of building new infrastructure, thus minimising duplication of efforts.
- Initiate development of an Android and/or iOS based free application about IPBES and the biodiversity and ecosystem services models and scenario analyses presented in Deliverable 3c to take advantage of new technologies to reach different stakeholder groups.
- Encourage IPBES to effectively engage local and indigenous knowledge from the first stage of planning scenarios in order to allow co-definition of the problem, to increase trust and understanding between participatory stakeholders, and to reduce uncertainty in the scenarios.
- Develop an integrated set of biodiversity and ecosystem services indicators that are based on scientific and traditional knowledge. These indicators could include or have links to local and regional traditional knowledge systems to enhance socio-ecological scenarios and models.
- Produce standardised training modules that are made available to government officials, decision makers and practitioners as a means of strengthening their capacity to draw appropriately on available data. The training modules could also raise awareness of the available data as it evolves.

7.6.4 Improving capacity-building relating to data management and infrastructure

IPBES could:

- Invite IPBES countries to participate in matchmaking projects, programmes and events, to enhance resource sharing for biodiversity and ecosystem services modelling and scenario development. Data sharing can demonstrate cost effectiveness of forecast-based policy-making in resource management sectors such as agriculture and biotechnology, protected areas management, forestry, nature conservation, and coastal zone management.
- Develop tools to improve and adapt models of species occurrence data.
- In cooperation with existing regional and international institutional networks and respective human resources, cultivate cooperative web-based digital products on biodiversity, modelling, scenarios building, accuracy improvement, and implementation that are needed to support robust modelling outcomes.
- Initiate development of a set of biodiversity and ecosystem services indicators and indices where indirect statistics of existing biodiversity indicators/indices and platforms could serve as a starting guideline.

7.6.5 Incorporating traditional and local knowledge

To achieve an effective integration of traditional knowledge and socio-ecological feedbacks in models and scenarios for biodiversity and ecosystem services IPBES could:

- Work to identify universities, research institutions and Non-Governmental Organizations (NGOs) with experience and/or with existing relationships that enable integration of traditional and local knowledge into development of biodiversity and ecosystem services scenarios or models over both short and long time scales.

-
- Build capacity of indigenous and local knowledge networks through the identification of leadership and educational opportunities and mechanisms to enhance communication between indigenous organisations and local governments.
 - Establish agreements of cooperation between local governments and indigenous technical personnel and organisations for transfer of knowledge as well as for coordination with educational entities to promote incorporation of information on biodiversity and ecosystem services into educational curriculum.
 - Develop policy relevant scenarios backed by rigorous scientific data and local knowledge to decision makers which involve 'good' integration of scientific, social, economic and local information, for telling a good storyline. Apply a balanced approach (just enough data to appropriately inform the stakeholders) to develop scenarios and sufficient scientific data that help policy makers comprehend the impacts or changes under a given scenario.

References

- Arzberger, P., Schroeder, P., Beaulieu, A., Bowker, G., Casey, K. and Laaksonen, L., 2004: Promoting access to public research data for scientific, economic, and social development. *Data Science Journal*, **3**: 135-152.
- Ash, N., Blanco, H., Garcia, K., Tomich, T., Vira, B., Brown, C. and Zurek, M., 2010: *Ecosystems and human well-being: a manual for assessment practitioners*. Washington, DC, Island Press.
- Bagstad, K.J., Semmens, D.J., Waage, S. and Winthrop, R., 2013: A comparative assessment of decision-support tools for ecosystem services quantification and valuation. *Ecosystem Services*, **5**: 27-39.
- Bocking, S., 2004: *Nature's experts: science, politics, and the environment*. New York, New York, USA, Rutgers University Press.
- Bousquet, F., Barreteau, O., d'Aquino, P., Etienne, M., Boissau, S., Aubert, S., Le Page, C., Babin, D. and Castella, J.-C., 2002: Multi-agent systems and role games: collective learning processes for ecosystem management. In *Complexity and Ecosystem Management. The Theory and Practice of Multi-Agent Systems*, Janssen, M.A., ed., Londres, Edward Elgar Publishers, 248-286.
- Brooks, T.M., Lamoreux, J.F. and Soberón, J., 2014: IPBES ≠ IPCC. *Trends in Ecology & Evolution*, **29**(10): 543-545.
- Bulkeley, H., 2005: Reconfiguring environmental governance: Towards a politics of scales and networks. *Political Geography*, **24**(8): 875-902.
- Butchart, S.H.M., Walpole, M., Collen, B., van Strien, A., Scharlemann, J.P.W., Almond, R.E.A., Baillie, J.E.M., Bomhard, B., Brown, C., Bruno, J., Carpenter, K.E., Carr, G.M., Chanson, J., Chenery, A.M., Csirke, J., Davidson, N.C., Dentener, F., Foster, M., Galli, A., Galloway, J.N., Genovesi, P., Gregory, R.D., Hockings, M., Kapos, V., Lamarque, J.-F., Leverington, F., Loh, J., McGeoch, M.A., McRae, L., Minasyan, A., Morcillo, M.H., Oldfield, T.E.E., Pauly, D., Quader, S., Revenga, C., Sauer, J.R., Skolnik, B., Spear, D., Stanwell-Smith, D., Stuart, S.N., Symes, A., Tierney, M., Tyrrell, T.D., Vie, J.-C. and Watson, R., 2010: Global Biodiversity: Indicators of Recent Declines. *Science*, **328**(5982): 1164-1168.
- Castella, J.C., Trung, T.N. and Boissau, S., 2005: Participatory simulation of landuse changes in the northern mountains of Vietnam: the combined use of an agent-based model, a role-playing game and a geographic information system. *Ecology and Society*, **10**(1): 27.
- Chaudhary, S., Kandel, P., Banerjee, S., Uddin, K. and Chettri, N., 2014: An integrated assessment of the effects of natural and human disturbances on a wetland ecosystem: a retrospective from Koshi Tappu Wildlife Reserve, Nepal. ICIMOD, Kathmandu.
- Chettri, N., Shakya, B., Thapa, R. and Sharma, E., 2008: Status of protected area system in the Hindu Kush Himalaya: an analysis of PA coverage. *International Journal of Biodiversity Science and Management*, **4**(3): 164-178.
- CONDESAN and UMBROL, 2014: *Protocolo para la caracterización y monitoreo de actores relacionados con la gestión de recursos naturales – Versión 1.* . Quito, Ecuador, CONDESAN, RUMBOL, COSUDE.
- Cortner, H.M., M., 1999: *The politics of ecosystem management*. Washington, D.C., USA and Cambridge, UK, Island Press.
- Costanza, R., 2000: Visions of alternative (unpredictable) futures and their use in policy analysis. *Conservation Ecology*, **4**(1): 5.
- Costanza, R., Kubiszewski, I., Cork, S.J., Atkins, P., Bean, A., Diamond, A., Grigg, A., Korb, E., Logg-Scarvell, J., Navis, R. and Patrick, K., 2015: Scenarios for Australia in 2050: a synthesis and proposed survey. *Journal of Future Studies*, **19**(3): 49-76.
- Eddy, B.G., Hearn, B., Luther, J.E., van Zyll de Jong, M., Bowers, W., Parsons, R., Piercey, D., Strickland, G. and Wheeler, B., 2014: An information ecology approach to science–policy integration in adaptive management of social-ecological systems. *Ecology and Society*, **19**(3).
- Edwards, J.L., Lane, M.A. and Nielsen, E.S., 2000: Interoperability of biodiversity databases: biodiversity information on every desktop. *Science*, **289**(5488): 2312-2314.
- Feinsinger, P., 2001: *Designing field studies for biodiversity conservation*. Washington, D.C., Island Press.
- Folke, C., Carpenter, S., Elmqvist, T., Gunderson, L., Holling, C.S. and Walker, B., 2002: Resilience and Sustainable Development: Building Adaptive Capacity in a World of Transformations. *AMBIO: A Journal of the Human Environment*, **31**(5): 437-440.

- Francis, T.B., Levin, P.S. and Harvey, C.J., 2011: The perils and promise of futures analysis in marine ecosystem-based management. *Marine Policy*, **35**(5): 675-681.
- FRB, 2013: Scenarios de la biodiversité: un état des lieux des publications scientifiques françaises. FRB (Fondation pour la Recherche sur las Biodiversité), Paris, France.
- GBIF, 2013: Global biodiversity informatics outlook: delivering biodiversity knowledge in the information age. Global Biodiversity Information Facility, Copenhagen, Denmark.
- Gilani, H., Shrestha, H.L., Murthy, M.S.R., Phuntso, P., Pradhan, S., Bajracharya, B. and Shrestha, B., 2015: Decadal land cover change dynamics in Bhutan. *Journal of Environmental Management*, **148**: 91-100.
- Guralnick, R.P. and Neufeld, D., 2005: Challenges building online GIS services to support global biodiversity mapping and analysis: lessons from the mountain and plains database and informatics project. *Biodiversity Informatics*, **2**: 56-69.
- Gurung, D.R., Amarnath, G., Khun, S.A., Shrestha, B. and Kulkarni, A.V., 2011: *Snow-cover mapping and monitoring in the Hindu Kush-Himalayas*. Kathmandu, ICIMOD.
- Haines-Young, R., Tratalos, J., Birkinshaw, S., Butler, S., Gosling, S., Hull, S., Kass, G., Lewis, E., Lum, R., Norris, K., Potschin, M. and Walmsley, S., 2014: Work Package Report 7: Operationalising scenarios UNEP-WCMC, LWEC, UK National Ecosystem Assessment Follow on, United Kingdom.
- Harris, M.B., Semroc, B.L., Sneary, M., Savy, C.E., Besançon, C., May, I., & Ragle, J., The Integrated Biodiversity Assessment Tool: Site-scale Information for Better Development Decisions. <https://www.ibat-alliance.org/ibat-conservation/login>,
- Hjarding, A., Tolley, K.A. and Burgess, N.D., 2015: Red List assessments of East African chameleons: a case study of why we need experts. *Oryx*, **49**: 652-658.
- Hoffmann, M., Hilton-Taylor, C., Angulo, A., Böhm, M., Brooks, T.M., Butchart, S.H.M., Carpenter, K.E., Chanson, J., Collen, B., Cox, N.A., Darwall, W.R.T., Dulvy, N.K., Harrison, L.R., Katariya, V., Pollock, C.M., Quader, S., Richman, N.I., Rodrigues, A.S.L., Tognelli, M.F., Vié, J.-C., Aguiar, J.M., Allen, D.J., Allen, G.R., Amori, G., Ananjeva, N.B., Andreone, F., Andrew, P., Ortiz, A.L.A., Baillie, J.E.M., Baldi, R., Bell, B.D., Biju, S.D., Bird, J.P., Black-Decima, P., Blanc, J.J., Bolaños, F., Bolivar-G., W., Burfield, I.J., Burton, J.A., Capper, D.R., Castro, F., Catullo, G., Cavanagh, R.D., Channing, A., Chao, N.L., Chenery, A.M., Chiozza, F., Clausnitzer, V., Collar, N.J., Collett, L.C., Collette, B.B., Fernandez, C.F.C., Craig, M.T., Crosby, M.J., Cumberlidge, N., Cuttelod, A., Derocher, A.E., Diesmos, A.C., Donaldson, J.S., Duckworth, J.W., Dutson, G., Dutta, S.K., Emslie, R.H., Farjon, A., Fowler, S., Freyhof, J., Garshelis, D.L., Gerlach, J., Gower, D.J., Grant, T.D., Hammerson, G.A., Harris, R.B., Heaney, L.R., Hedges, S.B., Hero, J.-M., Hughes, B., Hussain, S.A., Icochea M., J., Inger, R.F., Ishii, N., Iskandar, D.T., Jenkins, R.K.B., Kaneko, Y., Kottelat, M., Kovacs, K.M., Kuzmin, S.L., La Marca, E., Lamoreux, J.F., Lau, M.W.N., Lavilla, E.O., Leus, K., Lewison, R.L., Lichtenstein, G., Livingstone, S.R., Lukoschek, V., Mallon, D.P., McGowan, P.J.K., McIvor, A., Moehlman, P.D., Molur, S., Alonso, A.M., Musick, J.A., Nowell, K., Nussbaum, R.A., Olech, W., Orlov, N.L., Papenfuss, T.J., Parra-Olea, G., Perrin, W.F., Polidoro, B.A., Pourkazemi, M., Racey, P.A., Ragle, J.S., Ram, M., Rathbun, G., Reynolds, R.P., Rhodin, A.G.J., Richards, S.J., Rodríguez, L.O., Ron, S.R., Rondinini, C., Rylands, A.B., Sadovy de Mitcheson, Y., Sanciangco, J.C., Sanders, K.L., Santos-Barrera, G., Schipper, J., Self-Sullivan, C., Shi, Y., Shoemaker, A., Short, F.T., Sillero-Zubiri, C., Silvano, D.L., Smith, K.G., Smith, A.T., Snoeks, J., Stattersfield, A.J., Symes, A.J., Taber, A.B., Talukdar, B.K., Temple, H.J., Timmins, R., Tobias, J.A., Tsytsulina, K., Tweddle, D., Ubeda, C., Valenti, S.V., Paul van Dijk, P., Veiga, L.M., Veloso, A., Wege, D.C., Wilkinson, M., Williamson, E.A., Xie, F., Young, B.E., Akçakaya, H.R., Bennun, L., Blackburn, T.M., Boitani, L., Dublin, H.T., da Fonseca, G.A.B., Gascon, C., Lacher, T.E., Mace, G.M., Mainka, S.A., McNeely, J.A., Mittermeier, R.A., Reid, G.M., Rodriguez, J.P., Rosenberg, A.A., Samways, M.J., Smart, J., Stein, B.A. and Stuart, S.N., 2010: The Impact of Conservation on the Status of the World's Vertebrates. *Science*, **330**(6010): 1503-1509.
- Horigue, V., Alino, P.M., White, A.T. and Pressey, R.L., 2012: Marine protected area networks in the Philippines: trends and challenges for establishment and governance. *Ocean & Coastal Management*, **64**(0): 15-26.
- IPCC, 2007: Summary for Policymakers. IPCC WGII, Climate Change 2007: Impacts, Adaptation and Vulnerability. Contribution of Working Group II to the Fourth Assessment Report of the Intergovernmental Panel on Climate Change [Field, C.B., V.R. Barros, D.J. Dokken, K.J. Mach, M.D. Mastrandrea, T.E. Bilir, M. Chatterjee, K.L. Ebi, Y.O. Estrada, R.C. Genova, B. Girma, E.S. Kissel, A.N. Levy, S. MacCracken, P.R. Mastrandrea, and L.L. White (eds.)]. Cambridge, United Kingdom and New York, NY, USA.
- IPCC, 2014: Climate Change 2014: Impacts, Adaptation, and Vulnerability. Part A: Global and Sectoral Aspects. Contribution of Working Group II to the Fifth Assessment Report of the Intergovernmental Panel on Climate Change. Cambridge University Press, [Field, C.B., V.R. Barros, D.J. Dokken, K.J. Mach, M.D. Mastrandrea,

- T.E. Bilir, M. Chatterjee, K.L. Ebi, Y.O. Estrada, R.C. Genova, B. Girma, E.S. Kissel, A.N. Levy, S. MacCracken, P.R. Mastrandrea, and L.L. White (eds.)], Cambridge, United Kingdom and New York, NY, USA.
- IUCN, 2006: Indicadores de Conocimiento Tradicional de América Latina y El Caribe. . CBD and FIIB., Seminario de Expertos de América Latina y el Caribe sobre Indicadores para las comunidades indígenas y locales y el Convenio sobre Diversidad Biológica. , Quito, Ecuador.
- IUCN, 2010: Information paper on IPBES.
- Klein Goldewijk, K., Beusen, A., Van Drecht, G. and De Vos, M., 2011: The HYDE 3.1 spatially explicit database of human-induced global land-use change over the past 12,000 years. *Global Ecology and Biogeography*, **20**(1): 73-86.
- Kowalski, K., Stagl, S., Madlener, R. and Omann, I., 2009: Sustainable energy futures: Methodological challenges in combining scenarios and participatory multi-criteria analysis. *European Journal of Operational Research*, **197**(3): 1063-1074.
- Leadley, P., Pereira, H.M., Alkemade, R., Fernandez-Manjarrés, J.F., Proença, V., Scharlemann, J.P.W. and Walpole, M.J., 2010: Biodiversity Scenarios: Projections of 21st century change in biodiversity and associated ecosystem services. Secretariat of the Convention on Biological Diversity, Technical Series 50, Montreal.
- Leff, E., 2011: *Aventuras de la epistemología ambiental: de la articulación de ciencias al diálogo de saberes*. México: Siglo XXI.
- Lehner, B. and Doll, P., 2004: Development and validation of a global database of lakes, reservoirs and wetlands. *Journal of Hydrology*, **296**(1): 1-22.
- MA, 2005a: *Ecosystems and Human Well-being: Scenarios, Volume 2*. Washington, DC, Island Press.
- MA, 2005b: *Ecosystems and human well-being: Multiscale assessments, Volume 4*. Washington DC, Island Press.
- Mace, G.M., Cramer, W., Diaz, S., Faith, D.P., Larigauderie, A. and Prestre, P.L., 2010: Biodiversity targets after 2010. *Current Opinion in Environmental Sustainability*, **2**: 1-6.
- Madlener, R., Kowalski, K. and Stagl, S., 2007: New ways for the integrated appraisal of national energy scenarios: the case of renewable energy use in Austria. *Energy Policy*, **35**: 6060-6074.
- Magnuszewski, P., Sendzimir, J. and Kronenberg, K., 2005: Conceptual modelling for adaptive environmental assessment and management in the Barylz Valley, lower Silesia, Poland. *International Journal of Environmental Research and Public Health*, **2**: 194-203.
- Mausser, W., Klepper, G., Rice, M., Schmalzbauer, B.S., Hackmann, H., Leemans, R. and Moore, H., 2013: Transdisciplinary global change research: the co-creation of knowledge for sustainability. *Current Opinion in Environmental Sustainability*, **5**(3-4): 420-431.
- McKenzie, E., Rosenthal, A., Bernhardt, J., Girvetz, E., Kovacs, K., Olwero, N. and Toft, J., 2012: Developing Scenarios to Assess Ecosystem Service Tradeoffs: Guidance and Case Studies for InVEST Users. World Wildlife Fund, Washington D.C.
- Mills, M., Weeks, R., Pressey, R.L., Gleason, M.G., Eisma-Osorio, R.-L., Lombard, A.T., Harris, J.M., Killmer, A.B., White, A.T. and Morrison, T.H., 2015: Real-world progress in overcoming the challenges of adaptive spatial planning in marine protected areas. *Biological Conservation*, **181**(0): 54-63.
- Morrison, T.H., McAlpine, C., Rhodes, J.R., Peterson, A. and Schmidt, P., 2010: Back to the future? Planning for environmental outcomes and the new caring for our country program. . *Australian Geographer*, **41**(4): 521-538.
- Nativi, S., Mazzetti, P., Saaranmaa, H., Kerr, J. and Tuama, E.O., 2009: Biodiversity and climate change use scenarios framework for the GEOSS interoperability pilot process. *Ecological Informatics*, **4**(1): 23-33.
- Pacheco, D., 2013: Vivir Bien en Armonía y Equilibrio con la Madre Tierra: una propuesta para el cambio de las relaciones globales entre los seres humanos y la naturaleza. Universidad Cordillera/Fundación de la Cordillera, La Paz, Bolivia.
- Parr, C.S., Wilson, M.N., Leary, M.P., Schulz, K.S., Lans, M.K. and Walley, e.a., 2014: The encyclopaedia of Life v2: providing global access to knowledge about life on earth. *Biodiversity Data Journal*, **2**: e1079.
- Paulsch, A., Heubach, K. and Heubach, C., 2015: Shaping capacity-building for stakeholder engagement with IPBES according to most urgent capacity-building needs, identified with experts from Eastern Europe and Central Asia. Report commissioned by the German IPBES Coordination Office,

- Pereira, H.M., Leadley, P.W., Proenca, V., Alkemade, R., Scharlemann, J.P.W., Fernandez-Manjarres, J.F., Araujo, M.B., Balvanera, P., Biggs, R., Cheung, W.W.L., Chini, L., Cooper, H.D., Gilman, E.L., Guénette, S., Hurtt, G.C., Huntington, H.P., Mace, G.M., Oberdorff, T., Revenga, C., Rodrigues, P., Scholes, R.J., Sumaila, U.R. and Walpole, M., 2010: Scenarios for Global Biodiversity in the 21st Century. *Science*, **330**(6010): 1496-1501.
- Pereira, H.M., Ferrier, S., Walters, M., Geller, G.N., Jongman, R.H.G., Scholes, R.J., Bruford, M.W., Brummitt, N., Butchart, S.H.M., Cardoso, A.C., Coops, N.C., Dulloo, E., Faith, D.P., Freyhof, J., Gregory, R.D., Heip, C., Höft, R., Hurtt, G., Jetz, W., Karp, D.S., McGeoch, M.A., Obura, D., Onoda, Y., Pettorelli, N., Reyers, B., Sayre, R., Scharlemann, J.P.W., Stuart, S.N., Turak, E., Walpole, M. and Wegmann, M., 2013: Essential Biodiversity Variables. *Science*, **339**(6117): 277-278.
- Perrings, C., Duraiappah, A., Larigauderie, A. and Mooney, H., 2011: The biodiversity and ecosystem services science-policy interface. *Science*, **331**: 17-19.
- Peterson, G.D., Cumming, G.S. and Carpenter, S.R., 2003: Scenario Planning: a Tool for Conservation in an Uncertain World. *Conservation Biology*, **17**(2): 358-366.
- Pfeifer, M., Lefebvre, V., Gardner, T.A., Arroyo-Rodriguez, V., Baten, L. and Banks-Leite, C., 2014: BIOFRAG - a new adatabase for analyzing BIODiversity responses to forest FRAGmentation. *Ecology and Evolution*, **4**(9): 1524-1537.
- Pilkey, O. and Pilkey-Jarvis, L., 2007: *Useless Arithmetic: Why Environmental Scientists Can't Predict the Future*. New York, Columbia University Press.
- Pimm, S.L., Jenkins, C.N., Abell, R., Brooks, T.M., Gittleman, J.L., Joppa, L.N., Raven, P.H., Roberts, C.M. and Sexton, J.O., 2014: The biodiversity of species and their rates of extinction, distribution, and protection. *Science*, **344**(6187): 1246752.
- Primack, R., Rozzi, R., Feinsinger, P., Dirzo, R. and Massardo, F., 2001: *Fundamentos de Conservación Biológica. Perspectivas Latinoamericanas*. México, Fondo de Cultura Económica.
- Rands, M.R.W., Adams, W.M., Bennun, L., Butchart, S.H.M. and Clements, A., 2010: Biodiversity conservation: challenges beyond 2010. *Science*, **329**: 1298-1303.
- Reed, M.S., Kenter, J., Bonn, A., Broad, K., Burt, T.P., Fazey, I.R., Fraser, E.D.G., Hubacek, K., Nainggolan, D., Quinn, C.H., Stringer, L.C. and Ravera, F., 2013: Participatory scenario development for environmental management: A methodological framework illustrated with experience from the UK uplands. *Journal of Environmental Management*, **128**: 345-362.
- Renn, O., 2006: Participatory processes for designing environmental policies. *Land Use Policy*, **23**: 34-43.
- Robb, M., Harmsworth, G. and Awatere, S., 2014: Maori values and perspectives to inform collaborative processes and planning for freshwater management. landcare Research, Hamilton, New Zealand.
- Robertson, T., Doring, M., Guralnick, R.P., Bloom, D., Wiczorek, J. and Braak, K., 2014: The GBIF integrated publishing toolkit: facilitating the efficient publishing of biodiversity data on the internet. *PLoS ONE*, **9**(8): e102623.
- Roe, G.H. and Baker, M.B., 2007: Why Is Climate Sensitivity So Unpredictable? *Science*, **318**(5850): 629-632.
- Sala, O.E., Stuart Chapin, F., III, Armesto, J.J., Berlow, E., Bloomfield, J., Dirzo, R., Huber-Sanwald, E., Huenneke, L.F., Jackson, R.B., Kinzig, A., Leemans, R., Lodge, D.M., Mooney, H.A., Oesterheld, M.n., Poff, N.L., Sykes, M.T., Walker, B.H., Walker, M. and Wall, D.H., 2000: Global Biodiversity Scenarios for the Year 2100. *Science*, **287**(5459): 1770-1774.
- Sangha, K., LeBrocq, A., Costanza, R. and Cadet-James, Y., 2014: Ecosystems and indigenous well-being: an integrated framework. *Global Ecology and Conservation*, **4**: 197-206.
- Sangha, K.K., Butler, J., Delisle, A. and Stanley, O., 2011: Identifying links between ecosystem services and Aboriginal well-being and livelihoods in north Australia: Applying the millennium ecosystem assessment framework. *Journal of Environmental Science and Engineering*, **5**(7): 931-946.
- sCBD, 2010: Global biodiversity Outlook 3. Montreal.
- sCBD, 2014: Global Biodiversity Outlook 4. Secretariat of the Convention on Biological Diversity, Montreal.
- Scheraga, J.D., Ebi, K.L., Furlow, J. and Moreno, A.R., 2003: *From science to policy: developing responses to climate change*. Copenhagen: World Health Organization/World Meteorological Organization/United Nations Environment Programme.
- Sen, A., 1999: *Commodities and capabilities*. Oxford University Press.

- Sharma, E., Chettri, N. and Oli, K., 2010: Mountain biodiversity conservation and management: a paradigm shift in policies and practices in the Hindu Kush-Himalayas. *Ecological Research*, **25**(5): 909-923.
- Svob, S., Arroyo-Mora, J.P. and Kalacska, M., 2014: The development of a forestry geodatabase for natural forest management plans in Costa Rica. *Forest Ecology and Management*, **327**: 240-250.
- Swanson, D.Y. and Bhadwal, S., 2009: *Creating Adaptive Policies*. IISD, Ottawa.
- Tengö, M., Brondizio, E., Elmqvist, T., Malmer, P. and Spierenburg, M., 2014: Connecting Diverse Knowledge Systems for Enhanced Ecosystem Governance: The Multiple Evidence Base Approach. *AMBIO*, **43**(5): 579-591.
- Tengö, M., Malmer, P., Borraz, P., Cariño, C., Cariño, J., Gonzales, T., Ishizawa, J., Kvarnström, M., Masardule, O., Morales, A., Nobrega, M., Schultz, M., Soto Martinez, R. and Vizina, Y., Tengö, M. and Malmer, P., 2012: Knowledge for the 21 st Century: Indigenous knowledge, traditional knowledge, science and connecting knowledge system. In Tengö, M. and Malmer, P., eds. *Workshop Report Usdub, 10-13 April 2012*. pp. , Guna Yala Panama 19-23.
- Tompkins, E.L., Few, R. and Brown, K., 2008: Scenario-based stakeholder engagements: incorporating stakeholders preferences into coastal planning for climate change. *Journal of Environmental Management*, **88**: 1580-1592.
- UNEP, 2012: *Global Environment Outlook 5, Environment for the future we want*. Nairobi, Kenya, United Nations Environmental Programme
- van den Belt, M., 2004: *Mediated modeling: a system dynamics approach to environmental consensus building*. Island Press.
- Viciani, D., Lastrucci, L., Dell'Olmo, L., Ferretti, G. and Foggi, B., 2014: Natura 2000 habitats in Tuscany (central Italy): synthesis of main conservation features based on a comprehensive database. *Biodiversity and Conservation*, **23**(6): 1551-1576.
- Watson, R. and Freeman, O., 2012: *Future Vision*. Brunswick, Victoria, Scribe Publications.
- Wieczorek, J., Bloom, D., Guralnick, R.P., Blum, S., Doring, M. and Giovanni, R., 2012: Darwin Core: An evolving community-developed biodiversity data standard. *PLoS ONE*, **7**(1): e29715.
- Yahara, T., Ma, K., Darnaedi, D., Miyashita, T., Takenaka, A. and Tachida, H., 2014: Developing a regional network of biodiversity observation in the Asia-Pacific region: achievements and challenges of OP BON. In *Integrative Observations and Assessments*, Japan, Springer, 3-28.

Chapter 8 Improving the rigour and usefulness of scenarios and models through ongoing evaluation and refinement

Coordinating Lead Authors:

H. Resit Akçakaya (Turkey), Henrique M. Pereira (Germany)

Lead Authors:

Graciela Ana Canziani (Argentina), Cheikh Mbow (Keyna), Akira Mori (Japan), Maria Gabriela Palomo (Argentina), Jorge Soberon (Mexico), Wilfried Thuiller (France), Shigeo Yachi (Japan)

Contributing Authors:

Erle C. Ellis (USA), Miguel Fernandez (Germany), Sónia C. Ribeiro (Brazil), Marie Stenseke (Sweden), Niklaus E. Zimmermann (Switzerland)

Review Editors:

Neil Burgess (Denmark), Beth Fulton (Australia)

Purpose of this chapter: Adopts a more forward-looking perspective than the previous seven chapters; and thereby identifies major directions, both in underpinning science and in practical application, that need to be pursued to ensure the future rigour and utility of scenarios and models of biodiversity and ecosystem services.

Target audience: While less technical than most of the preceding chapters, this chapter is targeted mainly at readers seeking guidance on where best to direct future effort and support in developing and applying scenarios and models.

Key findings

There are significant gaps in data availability and data access for biodiversity and ecosystem services. The spatial, temporal and taxonomic coverage and resolution of monitoring of biodiversity change is heterogeneous. There are also gaps in information on social demand for ecosystem services and on high-resolution data of ecosystem properties relevant for ecosystem services. Much progress has been made in mobilizing data on biodiversity and ecosystem services, but significant barriers remain to data sharing. More efforts are required to provide easier access to well-documented data and models (Section 8.2.2 and 8.2.3).

There are already many models available to assess the impacts of drivers on biodiversity change and ecosystem services; however important gaps remain. These include gaps on (i) linkages between biodiversity and ecosystem services; (ii) ecological processes at temporal and spatial scales relevant to the Intergovernmental Platform on Biodiversity and Ecosystem Services (IPBES) assessments, including species interactions and community dynamics; (iii) early warning systems to anticipate ecological breakpoints and regime shifts; and (iv) coupling of, and feedbacks between, social and ecological components of ecosystems (Section 8.3.1).

Scenarios can allow effective use of data and models in decision-making. Both short-term scenarios (10 years) examining alternative policy options and long-term scenarios examining plausible futures are useful in assessing the impacts of drivers on biodiversity and ecosystem services. Exploratory scenarios foster creative thinking and exchange of viewpoints between different stakeholders, but do not always provide clear actions that decision makers can implement to reach desirable outcomes. Normative scenarios are more likely to provide clear policy pathways but have been criticized for being value laden (Section 8.4).

Scenarios can be improved through an iterative process that includes the steps of: engaging stakeholders, linking models to policy options, managing uncertainty, communicating the results and bringing scenarios outcomes to policy making. It is critical that assessments identify stakeholders relevant at the scale of the problem, including scientists, decision-makers and people with local and indigenous knowledge (ILK), and engage them early in the modelling and scenario analysis process (Section 8.4.1). Models and scenarios can improve the transparency of policy-making, by rendering the assumptions explicit and facilitating the comparison of multiple options (Section 8.4.2).

Key recommendations

IPBES could engage with existing processes on increasing data collection and data sharing. A key task is to identify common metrics for monitoring, modelling and reporting of biodiversity and ecosystem services and develop cost-effective approaches that are geared towards the needs of users at multiple scales (Sections 8.2.1 and 8.2.2). The Task Force on Knowledge, Information and Data (Deliverable 1d) could adopt existing data and model documentation standards and expand those as needed, make use of existing central repositories, liaise with relevant organizations to develop new ones, and participate in on-going efforts to assure proper credit to data and model providers.

The IPBES expert group on scenarios (Deliverable 3c) is encouraged to develop guidelines for verification and validation of models, and for assessing and managing uncertainty in scenario analysis and modelling. These guidelines need to be regularly updated based on scientific developments (Section 8.3.2). Complementary to visual validation, statistical analyses and accuracy tests are pivotal to make model validation and model comparisons robust, general and quantitative. It is important for the IPBES Regional and Global Assessments to use verified and validated models with a relevant pedigree and adopt appropriate methods for incorporating and communicating uncertainties. Depending on context and topical relevance, multiple models, of differing complexities and types, could be used to address structural uncertainties.

Thematic, Regional and Global Assessments are encouraged to use both short-term (e.g., 10 years) and long-term scenarios (e.g., 50 years) to assess the future of biodiversity change and ecosystem services and their implications for human well-being. For the regional assessments, existing long-term scenarios from other initiatives can be adopted and downscaled to the regions. Global assessment could develop a new set of long-term exploratory scenarios around key issues specific to biodiversity and ecosystem services (including those related to Sustainable Development Goals (SDGs)) identified by the relevant stakeholder community. Short-term scenarios comparing

Scope of this chapter:

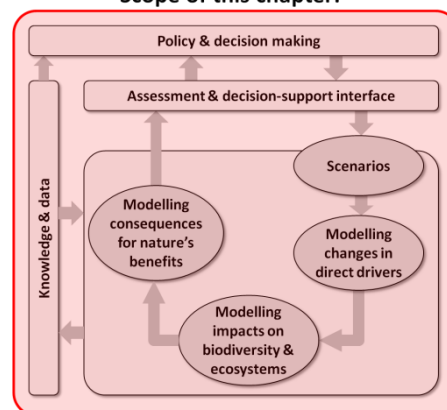

policy options using models and qualitative information can be developed both in regional and global assessments (Section 8.4.2).

The Task Force on Capacity-Building (Deliverable 1a/b) could support the use of models and scenarios in assessments at different scales, and interaction among social and natural scientists and multiple stakeholders. This includes activities that give planners and policy makers a better understanding of models and scenarios, including limitations and uncertainties, and activities to assist modellers in engaging further with policy and planning processes. Further research is needed on developing robust methods to elicit local and indigenous knowledge for the development of models and scenarios (Sections 8.4.2, 8.4.3 and 8.4.4). The Task Force on Indigenous and Local Knowledge (Deliverable 1c) may liaise with the Task Force on Capacity-Building in order to foster this research.

The follow-up work to the assessment on Scenarios and Modelling (Deliverable 3c), Conceptualization of Values (Deliverable 3d), and Policy Support (Deliverable 4c), could ensure that the review of available policy support tools and methodologies for scenario analysis and modelling continues to reflect best available science. Because of on-going research and rapid progress on many aspects of scenario analysis and modelling of biodiversity and ecosystem services, there is a need to continually update the review of available policy support tools and methodologies for scenario analysis and modelling of biodiversity and ecosystem services. Further, the Task Force on Knowledge, Information and Data (Deliverable 1d) could engage in an ongoing prioritization of research needs, in order to encourage basic research that advances scenario analysis and modelling in contexts and scales that are relevant to IPBES with the ultimate objective of decision support, especially research on including socio-cultural aspects in modelling and scenario development (Section 8.3.1.3).

8.1 Introduction

Previous chapters have demonstrated the variety of approaches to scenario analysis and modelling that can be used to inform decisions and evaluate policy options. Scenario analysis and modelling can address issues ranging from the local scale, such as assessing consequences of municipal land-planning options for ecosystem services and biodiversity, to the global scale, such as the impacts of alternative pathways of population economic growth on biodiversity and ecosystem services. Although IPBES assessments range only from sub-regional to global scales, this chapter also provides information relevant for local scales. Previous chapters have identified the problems or challenges, and reviewed existing solutions, for the use of models and scenarios in assessments of biodiversity and ecosystem services. The goal of this chapter is to chart the way forward for additional research and development that is required to take the use of models and scenarios to a whole new level of rigour and utility.

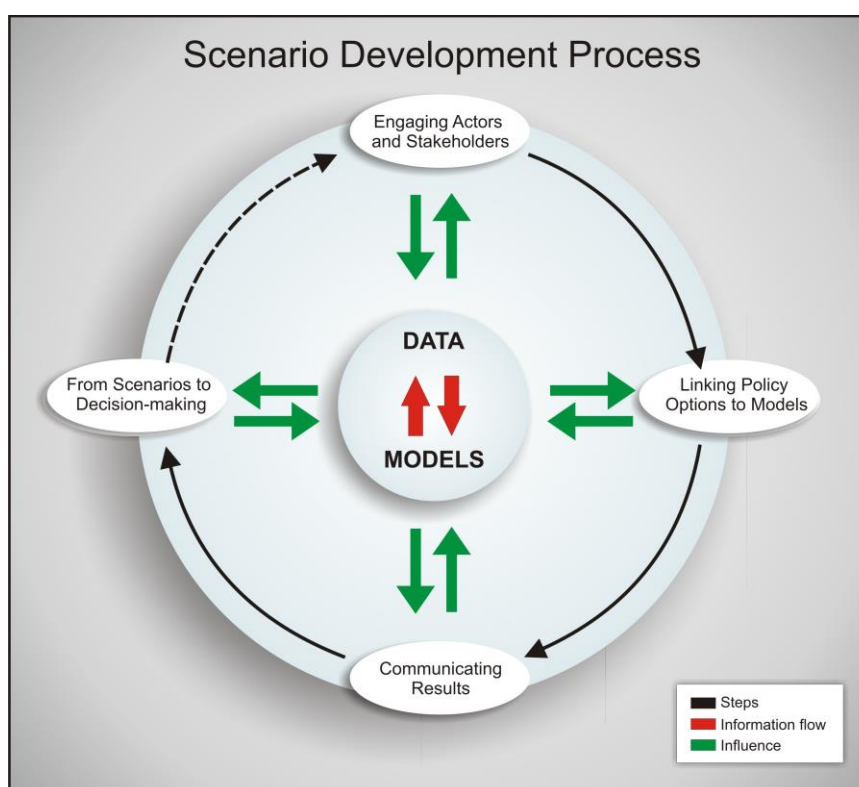

Figure 8.1: Scenario development and analysis process involving steps (in white ovals) such as engaging actors and stakeholders (including ILK), with each step interacting with the data and models (green arrows) and with information flow between models and data (red arrows). The dashed arrow indicates that the policy assessment involves several instances and actions, repeatedly involving actors and stakeholders; hence the iterative nature of this process.

The chapter is organised into three main sections. We first discuss approaches to improving the data used to calibrate and validate biodiversity and ecosystem services models, emphasizing linkages to various existing initiatives for biodiversity monitoring at national, regional and global scales. We then discuss basic and applied science research needed to improve models of biodiversity and ecosystem services, both by promoting development of new models and by encouraging and facilitating functional linkages among existing models and modelling platforms. Finally, we discuss directions for improving scenarios' relevance for policy-making. We consider four key steps of the iterative cycle of scenario development which are supported in models and data (Figure 8.1): (1) engaging actors and stakeholders; (2) linking policy options to models and scenarios; (3) communicating results; (4) using the scenario results and analysis for decision-making. In our discussions we use 'ecosystem services' as synonymous for 'nature's benefits to people', following the IPBES Conceptual Framework (Díaz et al., 2015).

This chapter emphasizes quantitative approaches to measure and forecast biodiversity and ecosystem services. However, we also cover inter- and transdisciplinary approaches, involving social sciences and stakeholders and point out corresponding research needs and best practices.

8.2 Improving data

8.2.1 Identification of common metrics

Biodiversity has multiple dimensions, including genetic diversity, species diversity, functional diversity and ecosystem diversity, and can be measured in a multitude of ways (Noss, 1990; Pereira et al., 2012). Similarly, there are many ecosystem services and each ecosystem service can be quantified using different approaches, including biophysical, cultural and economic measurements (Daily et al., 2009; Hauck et al., 2016). Important challenges remain in bridging towards the socio-cultural values of ecosystem services (Martín-López et al., 2012). The values of nature, nature's benefits to people and good quality of life are plural and they can be considered from diverse dimensions, some of which are quantifiable and others that are not. Researchers often face the challenge of accessing adequate data for calibration and validation of models, as different initiatives monitor differently and even have diverging epistemologies. There is a lack of harmonization and integration of monitoring methods, datasets and approaches across observation communities (e.g., different research communities, governmental agencies, non-governmental organizations) and across countries (Pereira et al., 2013).

A key challenge is the identification of common metrics that could be used by the modelling and observation communities. A common set of metrics for observation and modelling of biodiversity and ecosystem services would foster collaboration between the modelling and observation communities. This would promote integration of data from different sources, foster the development of approaches to fill data gaps, and would facilitate calibration, validation of models and scenarios and inter-model comparison.

Currently two complementary approaches, at different levels of data abstraction, show promise (Table 8.1): the Essential Biodiversity Variables being promoted by the Group on Earth Observations Biodiversity Observation Network (GEO BON) (Pereira et al., 2013), and the biodiversity indicators adopted by the Convention on Biological Diversity (CBD) and supported by the Biodiversity Indicators Partnership (www.bipindicators.net) to assess progress towards the 2010 target and the 2020 Aichi biodiversity targets (Butchart et al., 2010; sCBD, 2010; Tittensor et al., 2014 ; sCBD, 2014).

In recent years, scientific communities of different physical and biological phenomena have started to identify essential variables that are critical for monitoring and modelling. The first such effort was the identification of the Climate Essential Variables by the Global Climate Observing System. Similarly, GEO BON has developed a process to identify Essential Biodiversity Variables. The idea behind this concept is to identify, using a systems approach, the key variables that should be monitored in order to measure biodiversity change. The Essential Biodiversity Variables are an intermediate layer of abstraction between the raw data, from in situ and remote sensing observations, and the derived high-level indicators used to communicate the state and trends of biodiversity. These variables can be used in models of the whole biosphere or parts of it as the main system variables. They can then be used to compare model simulations with data. For example, the population abundance variable is defined as a three dimensional matrix of population abundances per species, per location, per time. A gridded dataset of population abundances for a group of species requires the integration of population estimates from different methods and observers, and the interpolation of gap areas with models. Models for interpolation can use as inputs climate variables and other environmental variables, including variables that can be remotely sensed. A list of 23 Essential Biodiversity Variable candidates has been identified and organized into six major classes (Pereira et al., 2013): genetic composition, species populations, species traits, community composition, ecosystem structure, and ecosystem function (Table 8.1). An effort is on-going to identify appropriate monitoring schemes, propose data standards and develop global or regional datasets for each variable.

Some Essential Biodiversity Variables measure directly the supply of ecosystem services such as nutrient retention or net primary productivity (a measure closely related with the carbon sequestration service); Essential Biodiversity Variables can also be used to measure the supply of services dependent on the distribution of particular species, such as wild animals used for food or medicine (Díaz et al., 2015). But for some of these and other nature's benefits, it is

important to look at the entire ecosystem service supply chain, and incorporate the role of human activities and social preferences in models (Tallis et al., 2012; Karp et al., 2015).

Table 8.1

Examples of common metrics for observation, reporting, and modelling for each class of Essential Biodiversity Variables. For some Essential Biodiversity Variables there are related indicators that are being used to assess progress towards the CBD 2020 targets. Essential Biodiversity Variables development focuses on how to monitor or model, while indicator development focuses on how to report or communicate. Examples of models that project the evolution of an Essential Biodiversity Variable metric or an Aichi indicator under different scenarios are also provided.

References: ¹Pereira et al., 2013; ²CBD, 2015; ³Brook et al., 2000; ⁴Christensen and Walters, 2004; ⁵Harfoot et al., 2014; ⁶Guisan and Thuiller, 2005; ⁷Visconti et al., 2015; ⁸Jetz et al., 2012 ⁹Newbold et al., 2015; ¹⁰Alkemade et al., 2009; ¹¹Hurt et al., 2011; ¹²Nemec and Raudsepp-Hearne, 2013 ; ¹³Sitch et al., 2008.

Essential Biodiversity Variable Classes ¹	Essential Biodiversity Variable Metrics ¹	Aichi Indicators ²	Models
Genetic composition	Number of animals of each livestock breed and farmed area under each crop	Trends in genetic diversity of cultivated plants and of farmed animals	-
Species populations	Population abundance of selected species or functional groups	Trends in species populations; Trends in proportion of fish stocks outside safe biological limits; Trends in species extinction risk	Population Viability Analysis ³ ; Trophic Models of Ecosystems ^{4,5}
	Species distribution of selected species	Trends in species extinction risk	Species Distribution Models ⁶ ; Habitat Suitability Models ^{7,8}
Species traits	Leaf senescence for selected species	-	-
Community composition	Species richness of a community	Trends in degradation of forest and other habitats	Dose-Response Models ^{9,10}
Ecosystem structure	Proportion of cover of each habitat type	Trends in extent of forest and other habitats	Integrated Assessment Models ¹¹
Ecosystem function	Nutrient retention	Trends in nutrient levels	Ecosystem Service Models ¹²
	Net primary productivity	Trends in carbon stocks	Dynamic Global Vegetation Models ¹³

For instance for wood production, supply can be assessed by standing biomass, demand by timber harvest and benefit by the market value of timber products (Tallis et al., 2012). GEO BON has proposed a set of metrics to monitor ecosystem services globally at different stages of the supply chain (Tallis et al., 2012; Karp et al., 2015). The Mapping and Assessment of Ecosystem Services initiative has identified a wide range of indicators and measures for provisioning, regulating and cultural services tailored to each major category of ecosystem in Europe: forests, agro-ecosystems, freshwater and marine (EC, 2014). A set of ecosystem service measures has also been proposed by the Final Ecosystem Goods and Services Classification System or FECS-CS (Landers and Nahlik, 2013) and by the Experimental Ecosystem Accounting of the United Nations (UN) System of Environmental Economic Accounting (UN et al., 2014). Many ecosystem services (e.g., some regulating services) cannot be easily directly observed and models play a key role in their assessment (Table 8.1).

The identification of common metrics can also be based on aggregated indicators and indices (van Strien et al., 2012). Over the last decade several biodiversity indicators have been used to report on biodiversity change at the national and global level (Butchart et al., 2010; Tittensor et al., 2014; CBD, 2015). The Biodiversity Indicators Partnership (<http://www.bipindicators.net>) has played an important role in this process. Indicators condense a wealth of data into a few values. For instance, one specific indicator for Trends in Species Populations (Table 8.1), the Living Planet Index (LPI), condenses information on population counts of several thousands of vertebrate populations into a single global value per year, which inform on global vertebrate population reductions relative to a base year. Another specific indicator for Trends in species extinction risk (Table 8.1), The Red List Index (RLI) (Butchart et al., 2004; Baillie et al., 2008), condenses assessments of species status of >20 000 species into a single value for a time point which can be compared with values from previous time points to assess if there has been an acceleration or deceleration of biodiversity loss.

It is possible to model either the more disaggregated data of each Essential Biodiversity Variable or the more aggregated data of biodiversity indicators and indices. For instance, many models are available to develop scenarios for population abundances or occupancy across ranges of individual species or groups of species (Table 8.1). But it is also possible to model the dynamics of aggregated indices such as mean species abundance or species richness at local to global scales (Nicholson et al., 2012). A particular challenge of using species richness or species abundance indices instead of the disaggregated data is the choice of the appropriate aggregated metric. There is a wide range of metrics being used to describe change in community composition, such as species richness, phylogenetic diversity, Simpson's diversity index, geometric mean abundance, arithmetic mean abundance, just to name a few (van Strien et al., 2012; Buckland et al., 2005; Lyashevskaya and Farnsworth, 2012). It is also possible to just focus on a subset of species such as rare or endemic species versus abundant species or threatened versus non-threatened species. The Essential Biodiversity Variables framework is particularly flexible in this regard, as calculating an index of an Essential Biodiversity Variable can result in another Essential Biodiversity Variable: e.g., using occupancy data for a set of species in a community to calculate species richness (Table 8.1). Furthermore, Essential Biodiversity Variables can be modelled globally integrating in situ observations and remote sensing and used as inputs to the calculation of spatially explicit indicators (www.geobon.org/essential-biodiversity-variables/ebv-classes/).

Understanding the upstream drivers and pressures and the downstream impacts and management responses are crucial to assess biodiversity and ecosystem services. The Drivers-Pressures-States-Impacts/Benefits-Responses (DPSIR) indicator framework allows for the consistent assessment of the dynamics of social-ecological systems (Sparks et al., 2011), and it is used to develop scenarios for biodiversity and ecosystem services (Pereira et al., 2010). The Aichi biodiversity targets of the Convention on Biological Diversity for the year 2020 are organized into five strategic goals that closely follow the DPSIR framework and can be assessed by using indicators for each target component (Tittensor et al., 2014; Leadley et al., 2014). The DPSIR framework also makes clear that the variables used as outputs of some models can be the inputs of other models. A socio-economic model may project changes in the harvest pressure of fish stocks, leading to changes in the abundance of different species. In turn this change in the ecosystem state may lead to changes in the fish provisioning from the ecosystem. Therefore, the choice of metrics has to take into account the interoperability of different models. Finally, metrics or indicators could be chosen so that they are able to detect biodiversity trends reflecting changes in pressures or policy and management (Nicholson et al., 2012). Indicators at regional scales or for specific groups of taxa (e.g., taxa vulnerable to a specific driver) may be more likely to do so than generic global indicators.

It is important for IPBES to engage in processes which aim at identifying common metrics of biodiversity and ecosystem services in order to guarantee that the metrics, associated monitoring methods and data standards, serve the needs of assessments users. Therefore, the participation of all IPBES stakeholders is important to ensure a balanced choice of metrics.

Regional and global IPBES assessments could report results of models and scenarios using a set of common metrics for biodiversity, including selected Essential Biodiversity Variables and/or Aichi Indicators (Table 8.1). Models of nature's benefits could use the standard classification of ecosystem services such as the Common International Classification of Ecosystem Services or CICES (EC, 2014), and common metrics such as the ones identified by GEO BON (Tallis et al., 2012) or the United Nations System of Environmental-Economic Accounting (UN SEEA) (UN et al., 2014). Indeed, the Task Force on Data and Knowledge has already proposed a list of indicators that could be used by Regional IPBES Assessments (IPBES/3/INF/4, <http://ipbes.net>). This set of indicators could be further explored by a Task Force on Modelling and Scenarios, which would also update regularly the guidelines presented in the current report.

Regarding socio-cultural values, it is important to recognize the complexity of incommensurable values and, if possible, use practical ways of dealing with it (IPBES/3/INF/7, <http://ipbes.net/>). Assessments could be explicit about which value dimensions were included in the scenarios, which ones could not be included and what are the implications of this selection (IPBES/3/INF/4, <http://ipbes.net/>).

8.2.2 Increasing data availability for model calibration and validation

Despite recent increases in the variety and amount of biodiversity-related data, there are significant gaps with respect to quantity and quality (Brooks and Kennedy, 2004), and significant biases in the availability of biodiversity and ecosystem services data (Box 8.1). Reasons for these gaps include lack of financial support for long-term monitoring, lack of local capacity, and limited international collaboration on developing globally representative monitoring programs (Scholes et al., 2012).

Different technical and strategic approaches could be taken for overcoming biases and gaps in data availability of biodiversity and ecosystem services. IPBES could identify critical gaps and promote the enhancement of (i) monitoring programs, (ii) the mobilization of data, and (iii) modelling for interpolation, estimation and other methods for filling data gaps.

In many cases, existing databases can be improved with concerted and coordinated efforts to increase spatial (regional) coverage, spatial resolution (e.g., smaller grid size or denser sampling points), temporal resolution (regular

and frequent observations), and temporal coverage (long-term, sustainable monitoring for the future; historical reconstruction for the past). For example, the Projecting Responses of Ecological Diversity In Changing Terrestrial Systems (PREDICTS) database collected data from existing literature of 78 countries representing over 28,000 species (Hudson et al., 2014), including invertebrates, vertebrates, and plants in terrestrial ecoregions around the world. However, the areas covered by the database are not balanced, but representative of the data availability (see also Figure 8.2), indicating a need for improvement on existing data. Monitoring programs could have a data strategy that supports intelligent choices about what and how to measure (Section 8.2.1); and be cost-efficient, sustainable through space and time, and effective, avoiding duplication (Box 8.2). For instance, in terms of taxonomic coverage, adding large numbers of species in poorly studied taxonomic groups may not be cost effective. However, a taxonomically sampled approach, as used in the *Sampled Red List Index* (Baillie et al., 2008), can provide taxonomic coverage in a cost-effective way. It would also be beneficial if monitoring programs would expand their efforts in observations of ecosystem services of most importance to human well-being, and if the data were more accessible (see Section 8.2.3).

New and promising approaches to obtaining data, and building and curating datasets include citizen science and crowd-sourcing (Silvertown, 2009; Wiggins and Crowston, 2011), and new technological tools such as automated data collectors and sensor networks that are embedded in the environment (Collins et al., 2006; Porter et al., 2009; Rundel et al., 2009; Benson et al., 2009). The new field of eco-informatics envisions building ecological data sets in the context of a 'data life cycle' that encompasses all facets of data generation to knowledge creation, including planning, collection and organization of data, quality assurance and quality control, metadata creation, preservation, discovery, integration, and analysis and visualization (Michener and Jones, 2012). Eco-informatics tools that support and assist various steps of the data life cycle include data management planning tools (e.g., <http://dmp.cdlib.org/>); metadata standards and tools; relational data bases which allow specification of constraints on the types of data that can be entered (i.e., data typing) assuring data integrity; scientific workflow systems, such as Kepler, Taverna, VisTrails and Pegasus (see Section 8.3.1.2); and cloud-computing resources.

In some cases, gaps in datasets can be filled using quantitative approaches such as statistical and modelling methods. One approach is imputation, which is often used when analysing large data sets of demographic traits (e.g., Di Marco et al., 2012; Penone et al., 2014), but relies on the assumption that relationships that exist in the data are also valid for the missing data. Another option for filling data gaps is making inferences based on allometric relationships between biological variables such as body size, metabolic rates, population density, generation time and maximum population growth rate (e.g., Damuth, 1987). Although allometric relationships have been used, for example, in size-structured food web models (Blanchard et al. 2009) and in models of energy budgets (Simoy et al., 2013), large uncertainties in the predicted values limits their usefulness in estimating parameters of predictive dynamic models at the species level. However, they may be useful, even in this context, if limited to groups of functionally related species (such as herbivorous mammals). A third approach involves sampling demographic parameters of population models using a 'generic life history modelling' approach. Although linking ecological niche and population models gives more realistic predictions of the effects of changing environmental conditions on species (Keith et al., 2008), widespread application of such coupled niche-population models is hampered by the availability of species-specific demographic data. The generic life history modelling (Pearson et al., 2014; Stanton et al., 2015) gets around this problem by using ensembles of population models designed to encompass the full set of life history parameters characteristic of a particular group of species. This approach avoids the need to obtain species-specific demographic parameters, which are rarely known, and enables generalising results beyond the well-studied species; however, this is achieved at the cost of not being able to make species-specific predictions of population dynamics (Pearson et al., 2014).

Remote sensing and in situ data are vital for modelling and monitoring environmental parameters relevant for biodiversity conservation (Buchanan et al., 2009; Kogan et al., 2011; Skidmore et al., 2015). Satellite remote sensing is useful for collecting data across different spatial and temporal scales. However, many users still lack the capability to deal with these data. Access to training and education in using satellite-based observations are essential in the future to address this issue (Turner et al., 2015). Some initiatives for increasing access to remote sensing data globally are the international Group on Earth Observations, European Space Agency's Climate Change Initiative (Bontemps et al., 2011), EU Copernicus Programme, and Committee on Earth Observation Satellites (ceos.org).

Box 8.1. Biases and gaps on data availability of biodiversity and ecosystem services

- **Regional biases in coverage:** Historically, ecologists studied non-urban but relatively human-accessible areas, in wealthy countries, resulting in a very uneven global distribution of study areas (Figure 8.2). The disparity among terrestrial, freshwater and marine realms is also noteworthy (Loh et al 2005).
- **Taxonomic biases in coverage:** Ecological studies have focused disproportionately on conspicuous species. Vertebrates, particularly birds and mammals, are much more often the focus of ecological studies than invertebrates and plants (Pereira et al., 2012). One of the most popular indices for measuring global biodiversity change, the Living Planet Index (LPI), is based on vertebrate populations only (Loh et al., 2005).
- **Spatial and temporal resolution:** Most ecological studies either have high spatial resolution and small spatial extent, focusing in detail on small areas, or have low spatial resolution and focus on larger regions. For some

scenario analysis and modelling approaches, high resolution data with global coverage are needed (Pereira et al. 2010). Such data exist for some biodiversity-related variables (such as forest cover data available at

<http://earthenginepartners.appspot.com>), but this is rare.

- **Thematic gaps:** There is a lack of regional and global consensus on what to monitor. Some Essential Biodiversity Variable classes such as species traits and genetic composition have received less attention from monitoring programs than others such as species populations. Regulating and cultural ecosystem services and particularly their benefits for populations are not monitored or only partially monitored in most places (Tallis et al., 2012).

BOX 8.2: Data strategy (modified from Scholes et al. (2012) and other sources): required properties of IPBES-relevant data:

1. Data that are aligned with the needs of scenario analysis and modelling at global, regional and local scales are relevant and useful for decision-making.
2. Global in coverage, but with sufficient resolution and accuracy at subnational scales to be useful to the main decision-makers at this scale.
3. Statistically sound basis for repeated measurements of biodiversity.
4. Following best practices for metadata specification.
5. Provisions for coordinating and managing data that are collected by disparate institutions and individuals for different purposes.
6. Sufficiently comprehensive in terms of taxonomic coverage.
7. Quality controlled, with well-defined standards for formats, codes, measurement units and metadata; traceability of the observation (including place and time of origin, the techniques used to make the observation, and methods used to modify the data); enforced data-typing
8. Cost efficient. Avoiding duplicative work in recording or analysing the same observations for the same time period.
9. Sustained. Ensuring data continuity and comparability over time, including provisions for long-term storage and data management.
10. Adaptive. Responsive to new technical possibilities, emerging societal needs and changing system state.
11. Interoperable. Data available to (and discoverable by) other parts of the system, with tools to enable analysis of data from different parts together. Requires metadata (see above) and harmonization of observations, analysis and data exchange standards and protocols.

Metrics and indicators of the quantity and quality of ecosystem services are essential to knowing if these services are being sustained or lost or how they need to be managed in order to sustain human well-being and biodiversity (Layke et al., 2012). While some ecosystem services (e.g., providing goods) can be directly quantified, most regulating, supporting and cultural services are less straightforward to quantify, so indicators or proxy data are required (Egoh et al., 2012). Development of robust indicators is an important step towards mapping ecosystem services and meeting biodiversity targets (Egoh et al., 2012). In recent years, ecosystem services modelling has improved with governmental demand for standardized practices to measure, value and map ecosystem services (Waage and Kester, 2014).

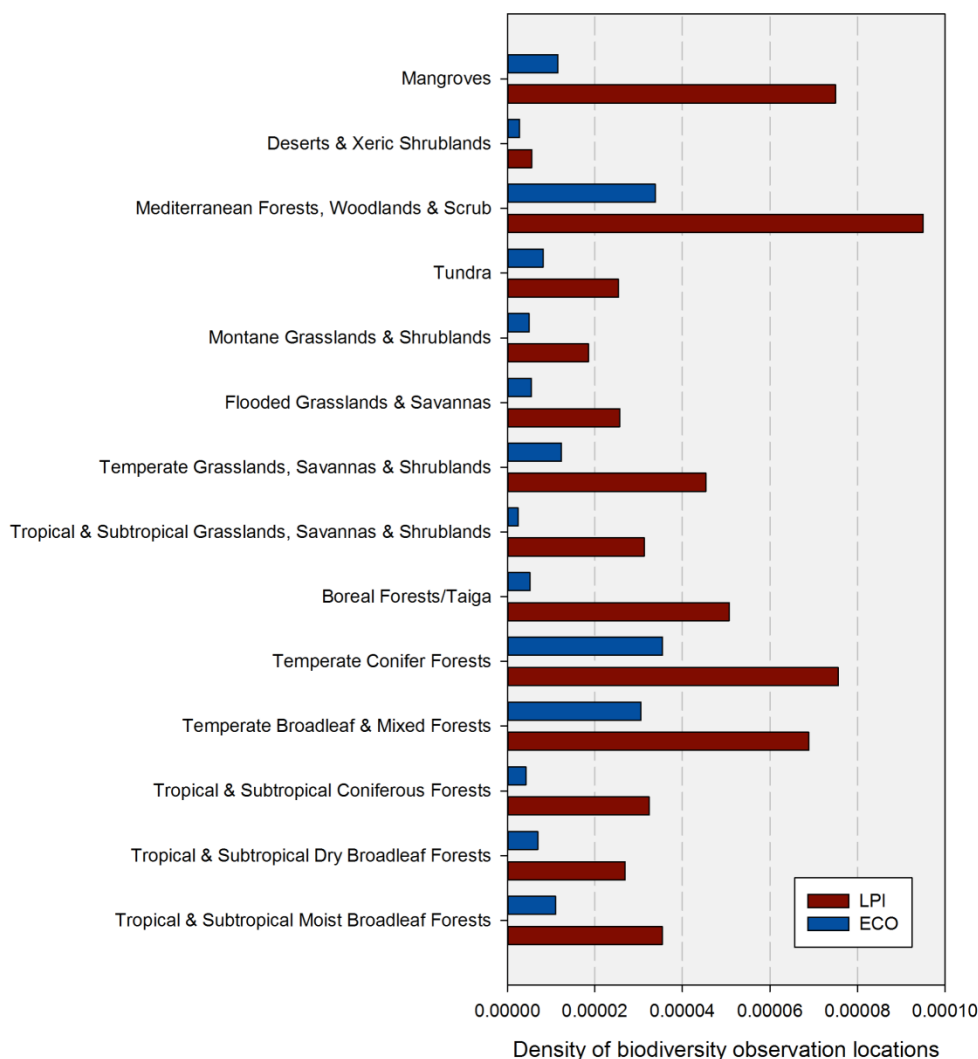

Figure 8.2: Number of observations per square kilometre calculated for each terrestrial biome (Olson et al., 2001). Red: Living Planet index (LPI) study sites for 10,000 vertebrates populations with population trends collected from 1970 to 2010 (Collen et al., 2009). Blue: Ecological studies (ECO), reported in the literature for 2,573 sites from 2004 to 2009 (Martin et al., 2012). See also Figure 7.3 for another illustration of regional biases in biodiversity studies.

8.2.3 Facilitating data access for model calibration and validation

Good practices in sharing data, developing open source databases and platforms, and documenting data access procedures need to be encouraged within the scientific community.

8.2.3.1 Improving data sharing

There is currently a major movement to ‘open data’, reflecting an increasing interest and demand for data being made publicly available (Reichman et al., 2011; Molloy, 2011). The CBD Aichi biodiversity target 19 emphasizes that biodiversity information needs to be ‘widely shared and transferred, and applied.’ In coming years, data release is expected to be more often required by funding sources and by research journals, and it will become a common norm of conduct of scientific societies. Note that this is not just a response to increasing calls for transparency from stakeholders; archiving data in public domains can potentially yield multiple benefits to the scientific community and the data providers. The opening-up of data not only helps reduce the duplication of work needed for data collection but also facilitates scientific exploration (Rüegg et al., 2014; Hobern et al., 2013) and helps address conservation problems. Considering that combining past inventory data with present data can serve as a surrogate of long-term monitoring (e.g., estimating a temporal change in species distribution in response to climate change; Moritz et al., 2008), digital mobilization of existing data is crucial. This applies not only to data on natural systems, but also social data on all aspects of human activities relevant to the status of, and pressures on, biodiversity and ecosystem services. Similarly, local and indigenous communities are sometimes the only repositories of historical data, and it is important to promote the uptake and publication of traditional knowledge (see Sections 7.3.2, 7.4.2 and 7.6.5).

Creating large datasets spanning several temporal, geographical and biological scales, which are essential for global assessments, require numerous inputs from a large number of contributors. However, such broad-scale sharing can have challenges. Field data, which are the crucial part for the majority of models, need enormous effort to be

collected. Therefore, data are undoubtedly precious and some people may feel reluctant to provide their data to public domains. Local communities may fear sharing their traditional knowledge because of concerns with knowledge misuse and the loss of their intellectual property (see Section 4.2.3).

For scientists, incentives for data sharing, including career rewards, are of importance to ensure further development of data archives (Borgman, 2012; Costello et al., 2013; Hobern et al., 2013). While potential benefits of open data have been extensively discussed in the literature, not enough emphasis has been placed on crediting and rewarding aspects of providing data. Advocates for opening up data tend to stand on the side of the ‘data user’, and do not necessarily view the issue from the side of the ‘data collector’. According to a survey, the most dominant answer from data collectors as a condition for the use of data is formal citation (Michener et al., 2012). Importantly, the advent of Digital Object Identifier (DOI) for data and encouragement to list data sources in reference lists are major factors that promote release of data. Despite this, some data collectors may instead prefer to openly publish only the metadata. However, conflicts exist as raw data are often required by the data users. Archiving data as a metadata requires users to resort to multiple, sometimes lengthy procedures to access raw data.

Given the ‘top-down pressure’ (Molloy, 2011) for open data, development of additional incentives and initiatives will be necessary for shortening the time for data to become available for models and scenarios. In this regard, inviting data collectors to be involved in data analysis may potentially help as data collectors have first-hand knowledge about the strengths and weaknesses of the data. This co-development and collaboration between data collectors and users may benefit both, leading to ‘win-win solutions’. This is one possible way to overcome the issue, but would not provide an ultimate solution, because it may not be feasible to include all data collectors as co-authors or to be able to coordinate an analysis with potentially large numbers of people. In summary, data collectors should be encouraged to publish their data on open repositories.

Lastly, those who are involved in constructing and maintaining web interfaces and large-scale repositories have not always been well acknowledged. They are a critical part in scientific communities to support data accessibility and facilitate data users. Importantly, a rapid expansion of policy and requirement for data depository may come with the heterogeneity in data quality. To screen out noisy or poor-quality data from being archived, database managers will likely play more important roles in the future. While a stringent set of criteria and protocols will be also required to maintain data quality, those who contribute to this process need further recognition.

8.2.3.2 Accessing and using data

Both biodiversity and ecosystem services data are increasingly being made publicly available (e.g., Boxes 8.3 and 8.4). In using such data, an important issue is data standardization. Models and scenarios often require multiple data types, sourced from different databases. Combining data from multiple sources may be difficult; for example, biodiversity information such as taxonomic names are often stored in different ways or following different published taxonomies. Work has been on-going to create a comprehensive formal taxonomic classification and creating architectures which can handle multiple taxonomies (Hobern et al., 2013). A number of tools are available to unify data from different sources, such as the Global Names Architecture which can help match and integrate names of species from different sources (<http://globalnames.org>).

The licensing form of data also needs to be considered. For instance, many institutions make data available as open access for non-commercial use; however, data licensing policies for commercial use may have some restrictions or require a fee for usage (e.g., Creative Commons multiple licensing modes). Some new frameworks that help retain currency and attribution back to the original data sources will also be important to strengthen the direct linkage between data collectors and users. Another issue is that the operability of data is different between databases and between data types, largely limiting the direct application of existing data for model calibration and validation. Considering the increasing visibility of data, platforms that facilitate user access will play a crucial part in the coming years (Box 8.3). While biodiversity information such as those archived in the Global Biodiversity Information Facility (GBIF; <http://www.gbif.org>), in the International Union for Conservation of Nature (IUCN) Red List of Threatened Species (<http://www.iucnredlist.org>), and in the Ocean Biogeographic Information System (<http://www.iobis.org>) are widely recognized and relatively well organized, data for ecosystem services tend to be collected individually and more diversely. The difficulty of coordinating development of repositories for large database for ecosystem services results from the lack of common and agreed language, definitions and framework on ecosystem services.

Generally, ecosystem services data are often produced by combining datasets sourced from multiple databases into a focal type of data (Tallis et al. 2012; MAES 2014). These datasets are diverse and can be physical, biological and social, such as satellite images, digital elevation models, Light Detection and Ranging (LiDAR) data, land/ocean use information, crowd-sourced data (e.g., for taxa distribution and phenology), meteorological data, human health statistics, cultural/religious information, and economic/financial statistics. Another reason why these diverse datasets are required is that, in real-world decision-making, it is important to identify trade-offs and synergies between multiple services (e.g., Brandt et al., 2014; Bateman et al., 2013). Although some tools to facilitate data use are now becoming open and available (Chapter 7), handling such different datasets needs multidisciplinary and interdisciplinary skills and knowledge, which is not easy for the majority of users. At the local scale, the shortage of human resources can be as serious as data incompleteness. Another issue that needs to be addressed is cultural values,

which are heterogeneously distributed across the globe. Localized information such as traditional knowledge, which would be tightly associated with cultural ecosystem services, have not been well archived.

Currently, some synthesized information, which potentially facilitates non-expert use of ecosystem services information, is available online. For example, the Ecosystem Service Valuation Database of The Economics of Ecosystems and Biodiversity (TEEB) (<http://www.fsd.nl/esp/80763/5/0/50>), gives the global overview of the estimates of monetary values of ecosystem services, potentially benefiting local stakeholders who are unfamiliar with environmental economics. Another example is the Global Forest Change (<http://earthenginepartners.appspot.com>), which makes it possible for groups without a remote-sensing expertise to visualize and assess the changing status of forest coverage in a specific region of interest Hansen et al., 2013. Although such frameworks for increasing the availability of ecosystem services data are currently emerging, comprehensive ecosystem services database would require collaboration among relevant organizations, including IPBES.

In addition to open data, open tools are becoming increasingly numerous and available. However, it is crucial to assist different users in the use of diverse datasets. In this regard, it is desirable to expand opportunities for learning how to handle different types of data, including online-learning modules and webinars that can be accessible worldwide. Many organizations, universities and research institutes now provide various databases; in addition to the information regarding the types of available data, they could also be encouraged to provide documentation and tools on how to use these data (also see Chapter 7). The growing appreciation of the need to communicate science and access information in all fields will likely make such development easier.

BOX 8.3: Examples of good practices in sharing biodiversity data at the species level

A. Databases of occurrences, trends, and threats

- GBIF: occurrence data -- <http://www.gbif.org>
- IUCN Red List: threat category, range map, and information on population, trends, ecology, distribution, threats and conservation measures -- <http://www.iucnredlist.org/>
- Global Population Dynamics Database: time series of population abundances or indices -- <http://www3.imperial.ac.uk/cpb/databases/gpdd>
- North American Breeding Bird Survey: population trends and relative abundances of North American bird species -- <https://www.pwrc.usgs.gov/bbs/>
- Map of Life: trends and occurrence data -- <http://mol.org>
- Global Invasive Species Database: native and invaded ranges -- <http://www.issg.org/database/welcome/>
- WoRMS: taxonomy and distribution of marine species -- <http://www.marinespecies.org>
- OBIS: Ocean biogeographic information system: occurrence data -- <http://www.iobis.org>
- EOL: Encyclopedia of Life -- <http://eol.org>
- AlgaeBASE: taxonomic and distribution data on algae species -- <http://www.algaebase.org>

B. Databases of demography and life history characteristics

- TRY: Plant Trait Databases -- <https://www.try-db.org/>
- COMPADRE: matrix (demographic) models for plant and animal species -- <http://www.compadre-db.org>
- MAPS: Monitoring Avian Productivity and Survivorship -- <http://www.birdpop.org/pages/maps.php>
- BROT: plant trait database for Mediterranean Basin species -- <http://www.uv.es/jgpausas/brot.htm>
- AnAge: Database of traits such as longevity, body size, age of first reproduction, etc. for animal species -- <http://genomics.senescence.info/species/>
- PanTHERIA: life history, ecology, and geography of extant and recently extinct mammals (Jones et al. 2009 <http://esapubs.org/archive/ecol/E090/184/>)
- FishBase: size and other biological information on fishes -- <http://www.fishbase.org/home.htm>
- SeaLifeBase: size and other biological information on marine species -- <http://www.sealifebase.org>
- EltonTraits (Wilman et al., 2014): foraging ecology of birds and mammals -- <http://www.esapubs.org/archive/ecol/E095/178/>

BOX 8.4: Examples of good practices in sharing ecosystem services and biodiversity data at the ecosystem level

A. Biodiversity, ecosystems and environmental databases

- BISE: Biodiversity information system for Europe collect databases on biodiversity and habitat types (<http://biodiversity.europa.eu>)
- EcoDB numerical data of gas fluxes and micrometeorology in agricultural fields, wetlands and grasslands. (<http://ecomdb.niaes.affrc.go.jp>)
- NOAA Global Oceanographic and Atmospheric I Data (<http://www.ngdc.noaa.gov>)
- Sea Around Us : information about fisheries and fisheries related data (<http://www.seaaroundus.org>)
- EDGAR: Emissions Database for Global Atmospheric Research (<http://edgar.jrc.ec.europa.eu/>)
- ACP Environmental observatory (<http://acpobservatory.jrc.ec.europa.eu/>)
- EFDAC: Europe Forest resources database (<http://forest.jrc.ec.europa.eu/efdac/>)
- TreeBASE: a database of of phylogenetic information (<http://treebase.org/treebase-web/>)
- Global Land Cover Characterization (<http://edc2.usgs.gov/glcc/>)

B. Ecosystem services and management databases

- MESP Marine Ecosystem Services Partnership: information on the human uses of marine ecosystems around the world. (<http://www.marineecosystems-services.org>)
- Ecosystem-based management tools: information about coastal and marine planning and management tools (<http://www.ebmtools.org>)
- FAOSTAT : provides time-series and cross sectional data relating to food and agriculture (<http://faostat3.fao.org/>)
- Joint Research Centre : database on Ecosystem services (<https://ec.europa.eu>)
- ESP : The Ecosystem Services Partnership : a database on monetary values of ecosystem services (<http://www.fsd.nl>)

8.3 Improving models**8.3.1 Basic research to fill thematic gaps and build functional linkages**

There is a wide variety of approaches to scenario analysis and modelling that can now be used to inform assessment of status and trends, to assess future risks, and to evaluate policy options (Chapter 3, 4 and 5). Despite recent advances in these approaches, there are significant gaps, both in the types of models for analysing and forecasting different ecological processes (at all levels of organization, from individual to ecosystem), and in linkages between different types of models.

This section focuses on basic science needs, i.e., research directed towards further development of theoretical and conceptual underpinnings of ecological and social-ecological systems.

Most research of this type is included in the basic science research carried out by academic scientists in various disciplines. This section gives examples of research that would advance scenario analysis and modelling, in contexts and scales that are of interest to IPBES.

8.3.1.1 Thematic gaps

There is a need for research that leads to development of new types of models to analyse and forecast ecological processes and ecosystem services that have so far not been the focus of much research. In this section, we give a few examples of these ‘thematic gaps’.

Species interactions and community dynamics

Models for performing scenario analyses and projecting regional biodiversity dynamics under IPBES will need to incorporate species interactions and community dynamics (including, for example, trophic interactions and disease dynamics). There is already much progress in this area in marine systems, especially at the community and ecosystem levels (Fulton 2010). For example, the Ecopath with Ecosim (EwE) model (Christensen and Walters, 2004) combines trophic relationships, environmental indicators, and biomass dynamics in the marine environment at a range of scales from local to global scales. The model also incorporates the spatial and temporal dynamics primarily designed for exploring impact and placement of protected areas. It can be used to evaluate past and future impact of fishing and environmental disturbances as well as management and policy options. The mechanistic General Ecosystem Model

(Harfoot et al., 2014) is a process-based model that facilitates consideration of the ecological implications of human activities and decisions on both marine and terrestrial ecosystems. The model uses biological and ecological data of functional groups to explore the interactions between them and with the environment, and to make predictions about the ecosystem structure and function ranging from the local to the global scales.

Although there is also much theoretical and empirical research on species interactions and disease dynamics in terrestrial systems and at the species level, these developments have not been translated into predictive tools at large temporal and spatial scales (Thuiller et al. 2013). For instance, while it is generally acknowledged that much of the impact of climate change will be through disruption of existing species interactions and emergence of new ones (Van der Putten et al. 2010), most large-scale models that project impacts of climate change on biodiversity either exclude such interactions or incorporate them only implicitly or under simplifying assumptions (Albouy et al. 2014). When species interactions are explicitly included in predictive models of biodiversity, they are often limited to only two or few species, such as one-predator-one-prey (Fordham et al. 2013) and predator-prey-pathogen (Shoemaker et al. 2014); or they are limited to specific types of well-studied interactions such as pollination (Bascompte et al. 2006). Part of the reason for this thematic gap is that, in the context of projecting the effects of particular policy or management actions on specific systems, the challenges in community ecology are even greater than in population ecology of single species. In other words, our understanding of the dynamics of communities is less than that of populations of single species, thus making it difficult to develop models that have sufficient skills to directly inform policies and management.

Therefore, basic science investments that lead to incorporation of species interactions and community dynamics into scenario analysis and modelling at large spatial and temporal scales would benefit global and regional IPBES assessments. Research needs include large scale experiments (e.g., experimental translocations), long-term and large spatial scale monitoring of the effects of conservation or policy actions (e.g., monitoring following the establishment of protected areas and invasive species control measures), and studies designed to translate measurable properties (such as comparison of ecological niche models of potentially interacting species) to parameters commonly used in theoretical models of species interactions (such as interaction coefficients or partial derivatives of population growth equations).

Recent studies have attempted to improve the mechanistic understanding of the relationship between species diversity and ecosystem functioning by using a functional group (trait) approach instead of species richness. In terrestrial environments, a comparison between a trait-based approach and a taxonomic approach indicated that ecosystem functioning was predicted better by the trait composition rather than the number or abundance of species (Gagic et al., 2015). However, a review of over 110 experimental studies has shown that richness is positively associated with ecosystem function (Cardinale et al. 2006). An increase in species richness increases the ability of that functional group to exploit and deplete resources, such as primary space, food, or nutrients, which has usually been considered an indication of 'ecological performance' (Wieters et al., 2012). The diversity of these results suggest new modelling approaches that integrate biodiversity composition and ecosystem function, to achieve an improved understanding of ecological systems and provide more accurate predictions of future states and management outcomes are required.

Early warning of regime shifts

Another research need is in developing practical early warning systems to anticipate ecological breakpoints, tipping points, and regime shifts (Leadley et al. 2014a). Although much research has been done on regime shifts in ecosystems, there are significant gaps, with the result that no practical early warning system for regime shifts (i.e., a set of generally agreed-upon measurable indicators), is currently available for adoption by IPBES. While generally agreed-upon indicators may be desirable, they may not be possible given system specificity. Practical limitations include dependence on long-term time series data (which are not as practical as static measures such as spatial patterns often used at the species level), difficulty of determining critical thresholds for a specific ecosystem, difficulty of predicting the timing of the transition and the nature of the altered state.

At the species level, warning systems based on current status and recent trends of populations have been in use for decades (Mace et al. 2008), and have been recently tested under scenarios of climate change (Stanton et al. 2015). At community or ecosystem levels, warning systems based on statistical properties of time series - such as increasing temporal variance and autocorrelation, and slowdown of system recovery from small perturbations - have been proposed (Scheffer et al. 2009) and empirically tested (Carpenter et al. 2011). For example, Mumby et al. (2013) used ecological models and field data to show that coral reef systems likely have multiple attractors and they can shift to and get stuck in an undesirable (degraded) alternative stable state. A promising research direction is linking theoretical research on network robustness and empirical research on indicators of resilience, which have been largely unconnected so far (Scheffer et al. 2012). A related, and also promising, research direction is using time series data of ecological variables to infer causal drivers of ecological change. Regime shifts may be more predictable if the underlying ecological processes are understood. Methods such as maximum likelihood (Wolf & Mangel 2008), convergent cross-mapping (Sugihara et al. 2012), and Bayesian model selection (Shoemaker and Akçakaya 2014) have been used to infer causes of species decline and to separate causality from correlation.

Further development and refinement of existing approaches will help advance the use of mechanistic models for building early warning systems as well as for evaluating the effect of policy options on biodiversity and ecosystem services.

Response to variability and extreme events

One critical research need related to regime shifts, at both species and ecosystem levels, involves the effects of changes in environmental variability and environmental regimes, and biodiversity responses to extreme events (Zimmermann et al. 2009). In particular, global climate change is expected to result in increased frequency and intensity of extreme weather events.

Predicting the effects of the projected weather variability on the properties of biological systems (including their persistence and variability) requires multidisciplinary collaboration among climatologists and ecologists, as well as integrating information from demographic models, physiological models, and predictions of climatic variability.

Developing models for projecting biodiversity indicators

Many of the currently used or proposed indicators (see Section 8.2.1) are useful for assessing current status and recent trends of components of biodiversity and ecosystem services, but few can be projected into the future. Research that links indicators and modelling can fill this gap.

Such research would allow for simulation testing of indicators to evaluate their reliability and information content, which also supports the identification of indicators that can be used to not only measure the current status but also to forecast the future state of biodiversity and ecosystem services, based on scenario analysis and modelling. One key research direction is developing models that can project future values of biodiversity indicators for alternative policy options. For instance, in marine systems, size-based models generate simulated size distributions, abundance, and productivity of multiple species, which are then used to calculate size-based indicators and characterise potential future ecosystem states under alternative management options (Blanchard et al. 2014). Another example is the IUCN Red List threat category, a biodiversity indicator of species-level extinction risk, which has been projected under scenarios of climate change using coupled niche-demographic models (Stanton et al. 2015).

IPBES-relevant scales

Most basic ecological research involves short time periods and small spatial scales, which would be relevant to short-term scenarios and local scales. However, they may not be relevant to the long-term scenarios for global and regional assessments to be undertaken by IPBES. There is a need for investments in research on ecological processes at the spatial and temporal scales relevant to IPBES assessments. This is especially important for regional assessments, both because IPBES will undertake them first, and because global assessments will need data and model support from sub-global assessments to fill knowledge gaps. In addition, there is bias in taxonomic and regional coverage of basic research, with a disproportionate amount of research involving populations of few groups (such as birds and mammals), and focusing certain regions (such as northern temperate regions). There is also a need for academic modellers and ecologists to become more familiar with applied fields such as forestry, fisheries, and agriculture, where policy relevant models have been used at scales relevant to IPBES (e.g., Platts et al. 2008; Blanchard et al. 2012; Kok et al. 2014).

8.3.1.2 Functional linkage gaps between biodiversity, ecosystem services and human well-being

There is a research need to develop linkages concerning functionality between biodiversity and ecosystem function, human well-being and natural systems.

Coupling social and ecological models

One type of linkage that is needed is between human socio-economic systems and natural systems. Improving the coupling of the social and ecological components of models and scenarios requires well developed, specific feedbacks from the ecological to the social systems and vice versa (Carpenter et al. 2009; Figueiredo and Pereira 2011). Research on these matters requires not only an understanding of how people make decisions to enhance their well-being, but also an understanding of the context under which they make those choices. Moreover, it is important to consider if information about the effects or consequences of these decisions is available, and if available, if it is used in making decisions. These decision processes are poorly understood but remain essential.

Linkages between human and natural systems may have complex structures, and may form cascades. For example, the effect of human activities on the world's climate is fairly well studied. There are also studies on the second link, the effects climate change have on human activities, such as shifts in agriculture and urbanization. And the third link is the effect of these changes in human activities on biodiversity and ecosystem services, compounding the direct effects of climate change on natural systems. Other examples include the linkages among human population growth, land-cover change, and ecosystem services (Pereira et al. 2010; Brock et al. 2009). Such cascades of causal connections are often difficult to predict (Chapman et al. 2014; Watson 2014).

Understanding the linkages between the ecological and the social components and identifying the underlying

feedbacks and cascades are vital to understanding the dynamics of the coupled system. Understanding how people perceive that their well-being is affected by environmental conditions, how policies are designed and accepted, and how people may change their behaviour as their environment changes are essential components of scenario modelling (Perrings 2014). Moreover, an understanding of how values vary between individuals and groups, how they relate to context and scale and how they change through time is crucial for assessing nature's benefits to people and human well-being.

The modelling communities in the natural and social sciences are relatively isolated from each other, and a substantive collaboration effort is needed. Model co-design will promote intellectual fusion between communities, helping them to formalize and integrate different discourses into a consistent framework (Rindfuss et al., 2004). Such an effort will necessitate overcoming linguistic, epistemological, technical and other hurdles between the modelling communities. Moreover, in order to increase the policy relevance, including problem framing and the transparency relating to aspects such as social justice and equality, modelling and qualitative cultural research need to be brought into conversation.

It is thus critical to encourage research on the coupling of human and ecological systems that focuses on these causal chains and feedbacks as well as on other relations, and on the scale at which these linkages operate to help modellers make more adequate projections of future changes in biodiversity and ecosystem services.

Other types of coupling that are needed include those between ecosystem types, such as between the terrestrial and freshwater ecosystems. Greater understanding of the functional connectivity within and between terrestrial, freshwater and marine ecosystems would help address a variety of questions related to ecosystem services, for instance designing diffuse pollution mitigation measures to prevent downstream eutrophication.

Linking biodiversity and ecosystem services

A critical research need involves the functional linkages between biodiversity and ecosystem services (Mace, 2012; Díaz et al. 2007). As the previous chapters have emphasized (e.g., see Chapters 4, 6), there is only a limited number of models that attempt to predict the impact of ecological changes on human well-being (for some examples see Pattanayak et al. 2009; Bauch et al. 2015). Furthermore, many models and spatial assessments of ecosystem services rely on land-cover and other biophysical variables such as topography but have a limited treatment of the effect of biodiversity at the species and community levels, including much of the regional scale work carried out in Europe (Schulp et al. 2014) or at the global scale (Karp et al. 2015). There is a need for demonstrating the role of biodiversity and ecosystem health in underpinning ecosystem services and for reinforcing the understanding of the relationships between ecological mechanisms and ecosystem services to create the realistic end products for managers (Wong et al. 2015). One of the few well-developed connections is between pollinators and human well-being (see IPBES Thematic assessment of pollinators, pollination and food production). A particular challenge is modelling not only the supply or potential supply of ecosystem services, but also the service actually used or enjoyed by the people, which often requires assessing the demand for the service and the social preferences of the communities (Tallis et al. 2012; see IPBES Deliverable 3(d) on the diverse conceptualization of values). Another significant challenge is that existing models are usually one-way linked, which may not capture the non-linear dynamic linkages between different components of biodiversity and ecosystem services (e.g., see Chapter 6).

Developing such integrated models, tools, and methods will require basic research involving multi-disciplinary teams of scientists (including economists and social scientists, in addition to natural scientists) as well as policy makers and other stakeholders (see Section 8.4).

Integrating process-based and correlative approaches

Development of the types of functional linkages between different types of models of biodiversity and ecosystem services discussed above can be facilitated by research into process-based (mechanistic) as well as statistical (e.g., correlative) relationships.

For example, analysis of statistical relationships between environmental drivers (climate, land-cover) and biodiversity components (e.g., species occurrence) allows some predictive ability. Such an approach has been successfully implemented as ecological niche models and used to project the future potential distribution of species in response to environmental change (e.g., Guisan and Thuiller 2005). However, in order to predict beyond the current conditions, and to evaluate the impact of management and conservation options, a deeper understanding of ecological processes is needed. This need has led to the development of more mechanistic models that incorporate ecological processes such as dispersal and demography (e.g., Keith et al. 2008), and coupling of correlative and process-based approaches (Boulangéat et al. 2014). Similarly, the development of linkages discussed in this section will likely benefit from coupling of correlative or statistical methods with mechanistic models of ecological and socio-economic processes, such as some of the models incorporated in the Integrated Valuation of Ecosystem Services and Trade-offs (InVEST) package (Daily et al. 2009) or integrated assessment and system models.

Platforms for model linkage

On the technological side of developing these linkages, there is a need to encourage development of models that can communicate with (or that can be embedded in) software platforms that are designed for linking different models.

Two main types of such platforms are ‘scientific workflow managers’ and ‘integrated environmental modelling frameworks’. Both of these approaches allow users to assemble and run a system composed of existing simulation models that can exchange data at run time. Examples of scientific workflow managers include Kepler (kepler-project.org), with applications in areas such as ecological niche modelling (Pennington et al. 2007) and environmental sensor data analysis (Barseghian et al. 2010); VisTrails (vistrails.org), recently applied to habitat modelling (Morissette et al. 2013); and Taverna (<http://www.taverna.org.uk>), recently applied to mapping potential distribution patterns (Leidenberger et al. 2014). The integrated modelling frameworks include OpenMI (openmi.org), Object Modelling System (www.javaforge.com/project/oms), and Metamodel Manager (www.vortex10.org/MeMoMa.aspx), which have been applied to models of hydrology (Butts et al. 2014), sediment transport (Shrestha et al. 2013), trophic interactions (Prowse et al. 2013), and solar radiation (Formetta et al. 2013). An important difference between these systems is that the workflow managers are mainly designed for infrequent, unidirectional transfer of data among component models whereas the integrated modelling frameworks are designed for among-component interactions (i.e., feedbacks) and for frequent exchange of data among modules (e.g., passing key information at every time step), thereby allowing two-way interactions between two linked models.

Other technological improvements required for integrated or coupled models include compatible spatial and temporal scales (coverage and resolution; see Chapter 6); data-based and region- or system-specific functional relationships; and interacting drivers (see Chapter 2).

8.3.1.3. Evolving methodological reviews and research prioritization

Research on many aspects of scenario analysis and modelling of biodiversity and ecosystem services is progressing at a rapid rate. Many of the approaches reviewed in this report will be further developed in the near future; others may become obsolete. Therefore, there is a need to ensure, through ongoing updates and new evaluations, that the review of available policy support tools and methodologies for scenario analysis and modelling of biodiversity and ecosystem services continues to reflect best available science. Similarly, there is a need for ongoing prioritization of research needs. Some of the research and development directions and needs identified in this chapter will have already matured in the next few years, and others will not be pursued, or will be proven to be not beneficial.

Therefore, it is critical that IPBES develops mechanisms for research prioritization, in order to encourage basic research that advances scenario analysis and modelling in contexts and scales that are relevant to IPBES.

This could be through the IPBES expert groups on Scenarios and Modelling (Deliverable 3c), Conceptualisation of Values (Deliverable 3d), Policy Support (Deliverable 4c), and the Task Force on Knowledge and Data (Deliverable 1d), which could make recommendations to research funding agencies about the significant gaps that remain in our understanding of the fundamental processes that are the subject of scenario analysis and modelling used in IPBES assessments. Such recommendations would benefit from input from policy makers, resource managers and planners, both applied and academic natural resource modellers and researchers, and ecological, economic, and social scientists.

8.3.2 Verifying and validating models

To be of any use for IPBES and other applications such as conservation planning or for decision-making, models and ultimately scenarios need to have a full treatment and report of uncertainty together with a proper and sound validation.

In biodiversity and ecosystem modelling, the heterogeneity of data and the range of factors influencing the results mean that the tasks of analysis and validation can be complex. Model validation covers different approaches and goals, but the overall idea is to use a set of criteria to classify and identify an acceptable model. Agreement between model output and observed/experimental data of any sort can be analysed qualitatively using appropriate graphical design, to visualise model performance. In addition, and complementary to visual validation, statistical analyses and accuracy tests are pivotal to make model validation and model comparisons robust, general and quantitative. Model validation (or, assessment of model skill) is a growing topic area with existing precedents in biophysical, climate and weather modelling (e.g., for IPCC, see Flato et al. 2013). However, there is a lack of standardized terminology and approaches to validate biodiversity and ecosystem service models and their application for scenario building. IPBES could be the driving force to prepare such guidelines as they are critical for users to trust models and scenarios and for developing global or regional syntheses. In this development, model pedigrees could be highly valuable tools to build trust judging the output of existing and used biodiversity and ecosystem service models. Model pedigree is a measure of confidence the research community has in a given model and is influenced by factors such as testing and verification of internal model processes; the quality of the data used; acceptance and use of the model by a large part of the community; applications of the model to a wide variety of cases, questions and taxa; the transparency and documentation of the model structure, assumptions and functions; and the scientific and technical credibility of the model developers.

A model may be general (can be useful in many different situations), realistic (parameters and variables are based on

true cause-effect relationships), and precise (accurate quantitative output), but it is impossible to have a perfect model that can maximize all three of these attributes simultaneously (Levins 1966). Models are often built for gaining a deeper understanding of the interactions between systems' components and for responding to questions about the systems' functioning (thus increasing 'reality'). Hence, the limitations of a model need to be assessed from the start and adequately communicated to the stakeholders who will be using the outputs. There is a need for appropriate guidelines for validation that could be applicable to a large range of biodiversity, ecosystem process and ecosystem service models. The difficulty in creating such protocols is that the variety of existing models is large and will require different strategies. The expert group on Scenario and modelling could be the leading force for such standardizations.

There are several issues modellers and users should consider when validating a biodiversity or an ecosystem service model and associated scenarios.

The goal of the validation: There are several ways of validating a model and the appropriate approach depends on the overall purpose of the validation. The purpose of validation should thus always be clearly defined and reported since the subsequent tests, whether they are qualitative or quantitative, will be linked to that specific validation purpose. The output of the validation procedure gives important feedback to the modeller on how the models could be improved, but also to the end users on whether the model can be used, or with what confidence it can be used for a specific purpose. In biodiversity modelling, one may want a model that correctly predicts the equilibrium range of a species. In that case, visual inspection of observed and predicted maps and associated statistics would be sufficient. However, such a validation procedure will not give any information to the end-user or stakeholder on the ability of the model to simulate the transient dynamics of species in response to a given environmental change. For such purposes, modellers require dynamic models and time series of data for validation.

Model and scenario comparison: Model and scenario comparisons should also be part of the validation procedure. For any given phenomena, several alternative models and scenarios can be developed, for instance at different levels of complexity. Comparing several models or scenarios built or calibrated for the same system and purpose allow us to: (i) understand their respective behaviour, (ii) chose the best one if needed, (iii) understand the effects of structural uncertainty on model outputs; (iv) average the models or (v) build an ensemble forecast to visualize and apprehend the overall variation of the models and scenarios given the data and system (Araujo and New 2007). Species range modelling is one of the areas where statistical models and process-based models of increasing complexity can be benchmarked against observed data. Cheaib et al. (2012) compared eight different species distribution models from purely statistical models to highly complex individual-based models under current and future conditions. While varying the effects of environmental drivers, they singled out the assumptions made, the drawbacks therein, and the ability of these models to project the potential distribution of species (Cheaib et al. 2012). Although such evaluations and comparisons have been done in number of studies for modelling the distribution of species (Kearney et al. 2010; Morin & Thuiller 2009), of dynamic vegetation processes (Cramer et al. 2001), or of resulting ecosystem services (Bagstad et al. 2013), we argue that systematic comparison of different models and scenarios and the building of model ensembles to project both trends and uncertainties should be a gold standard, as is currently done in climate change research. Such comparisons, together with analysis of uncertainties are critically important if the outputs of such models are to be used for decision-making or conservation planning. Ensemble modelling or ensemble forecasting is the appropriate method in this regard if paired with appropriate validations and formulation of uncertainty.

Model predictions and scenarios: Most biodiversity and ecosystem services models are built to provide predictions based on scenarios, for instance under changing climate and land use. As such, these predictions can be compared with expert knowledge, experimental data, observed, and virtual data. A plethora of approaches and statistical techniques exist (e.g., residual mean square errors) and they have already been thoroughly compared and discussed. Clear predictions, using robust statistical methods, and generating enough data (either experimental or observational) are pivotal elements for reaching the level of quality needed for validation. Biodiversity and ecosystem services models are often subject to data limitations because of the difference between the scale of the prediction and the scale of measurement. For instance, most dynamic vegetation models use growth curves that are calibrated over dozens of individuals (of e.g., trees) measured in situ with precise climate measurements. These curves are then extrapolated over large spatial scales and with resolutions such as 20x20 km for which climate is highly smoothed. The outcome can then no longer be directly compared to the growth of single individual trees. To overcome this limitation, cross-scale validation has been proposed (using data generated at a finer scale to validate models built for a larger scale). But even here, the question of interchangeability of processes between scales has not been truly addressed (Morozov and Poggiale 2012).

Predictions involving future conditions pose special problems for validation, since the temporal scales are such that we often cannot test the validity of models in the future, which could be populated with previously unobserved phenomena. In this regard, biodiversity and ecosystem service models can be considered validated if they successfully predict past events (retrospective testing; e.g., Brook et al. 2000). However, the probability of making meaningful projections decreases with the length of the time period into the future.

A continuous exchange of validation data among developers and test teams should either ensure a progressive

validation of the models by time, or highlight the need for updated interpretations of the analysed system (population, ecosystem, community, or landscape). To this end, spatially and temporally dynamic models of biodiversity or ecosystem services must be validated against monitoring data.

8.3.3 Managing uncertainty in models

Linguistic and scientific uncertainty in models can be reduced by developing new technical approaches and by engaging stakeholders and local populations in the model development process.

With the rise of statistical and mechanistic predictive models of biodiversity and ecosystem services, quantifying, incorporating, and propagating uncertainty have become key issues. Regan (2002) recognized two main types of uncertainty in environmental science: scientific (also called epistemic) and linguistic (Table 8.2). As seen in Chapter 4, scientific uncertainty relates to the knowledge of the system and includes data bias and limitations, structural uncertainty, parameter uncertainty, extrapolation and interpolation, while linguistic uncertainty comes from the vague, ambiguous, imprecise and context-dependent vocabulary. The definition of a species as a unit and its general use is one simple example, and the word biodiversity is another. Although integrating linguistic uncertainty is not new in conservation biology where policy and decision-making are part of the process, it is generally ignored in most cases and only scientific uncertainty is considered.

Table 8.2

Sources of uncertainty and potential treatment. Adapted from Regan 2002 and Elith et al. 2002.

	Source of uncertainty	General treatments
Scientific uncertainty	Measurement error	Statistical techniques; use of intervals
	Systematic error	Recognize and remove bias
	Natural variation	Probability distributions, intervals
	Inherent randomness	Probability distributions
	Model uncertainty	Validation, revision of theory based on observation, discussion with end-user, prediction
	Subjective judgment	Degree of belief, imprecise probabilities
Linguistic uncertainty	Numerical vagueness	Sharp delineation, fuzzy sets, rough sets, super-evaluations
	Non-numerical vagueness	Use multidimensional measures than treat them as numerical
	Context dependence	Specify context
	Ambiguity	Clarify meaning
	Indeterminacy in theoretical terms	Make decision about future usage of term when need arises
	Under-specificity	Provide narrowest bounds

A model is as good as the assumptions behind its construction, that is, what is accepted as true or as certain to occur. Structural uncertainty is key when sub-models or assumptions are likely to be wrong or uncertain (see Chapters 4). Structural uncertainty can be addressed using validation (Section 8.3.2), and by using multiple models with alternative structures.

Data are essential for developing conceptual models that will later translate into quantitative or qualitative models, and also for calibrating and evaluating those models. When the information is incomplete, unreliable, imprecise, fragmented, contradictory, or in any way deficient, it is fundamental that stakeholders understand that even a simple model based on very general data can be useful at providing insight into the possible effects of different alternatives. In addition, there are diverse mathematical or statistical techniques that can deal with information deficiencies, including fuzzy inference systems and uncertainty-based information theory (Klir & Yuan, 1995; Cao 2010). One advantage of fuzzy inference systems is that they allow for the incorporation of qualitative information that local experts and stakeholders may volunteer to provide. This information may then be integrated into a more rigorous framework of model construction. Qualitative reasoning helps in the construction of *knowledge models* that capture insights from domain experts about the structure and functioning of the system (Recknagel, 2006). Artificial Neural Network models may also be helpful in situations in which a response variable should be estimated or its behaviour predicted as a function of one or several predictor variables. Artificial Neural Network models have been conceptualized as non-parametric statistical techniques because they do not require the fulfilment of the theoretical assumptions of parametric statistics. They are also considered as non-linear regression techniques.

The input data for biodiversity and ecosystem services models and scenarios are often uncertain and are specified as a range of values or as statistical distributions. Uncertainty analysis aims to quantify the overall uncertainty of model results in order to estimate the range of values the output could take (Regan et al. 2002). In recent years there has been an increasing interest in uncertainty analyses, partly motivated by the goal of keeping imperfect data in data-poor model environments instead of discarding them. Uncertainty and dependence modelling, model inferences, sampling design, screening and sensitivity analysis, and probabilistic inversion are among the most active research areas (Kurowicka & Cooke 2006). To date, despite few positive examples and the awareness that different algorithms likely result in different projections, biodiversity and ecosystem services models are too often used without clear reporting of the underlying uncertainty in parameter estimation or the uncertainty resulting from the input data (see Section 4.6.1).

Better integration of statistical analyses into parameter estimation of mechanistic models could foster appropriate characterization and reporting of uncertainty. Promising approaches for doing so include inverse modelling or Bayesian computation, which produce a probability distribution of the estimated parameters (the posterior distribution) that are relevant for the reporting of uncertainty (Hartig et al. 2012). So far, however, a full treatment of uncertainty has been considered too time-consuming and complex to be achieved in biodiversity and ecosystem services models, and a full integration and partitioning of the uncertainty originating from different sources (such as climate or land-use models) is difficult to achieve. To meet this challenge, there is a need for mathematical, statistical and computational skills that extend beyond the range of standard ecological expertise, and include novel techniques mixing deterministic and random concepts that are usually considered as independent skills and expertise. For instance, Bayesian calibration, comparison and averaging can be used in biodiversity and ecosystem service models to be used in IPBES assessments. These methods require a capacity of integrating process and parameter uncertainty and incorporating prior, even qualitative, knowledge. These approaches have mostly been tested with forest-gap models (van Oijen et al. 2011, 2013) but they could certainly be extended to many other types of biodiversity and ecosystem service models.

Pragmatic approaches are encouraged, for instance by sub-sampling alternative climate projections for the same scenario to obtain a basic representation of the uncertainty; or by considering that parameters in mechanistic models should not be fixed to one value but rather sampled from probability distributions representing uncertainty. While climate research has long started to produce such kinds of ensemble projections (e.g., the World Climate Research Programme (WCRP)'s Inter-Sectoral Impact Model Intercomparison Project (ISI-MIP)), this is not often done in biodiversity models, e.g., land use models. This situation poses serious challenges when modellers have an ensemble of climatic data and only few discrete scenarios of land use as input for deriving biodiversity scenarios into the future.

8.4 Improving Scenarios and Policy Support

Scenarios play a major role in assessments by helping decision makers to explore the impact of a broad range of policy options and socio-economic pathways on biodiversity, ecosystem services and human well-being. Quantitative models are one of the main tools used in scenarios to assess such impacts. In this section we identify areas for improvement of scenarios in biodiversity and ecosystem services assessments at each step of the scenarios development iterative cycle (Figure 8.1). We first examine how best to engage stakeholders in scenario development. Next we discuss how to improve the links between models and policy options in scenarios. We then examine how the results of scenarios can be better communicated to policy-makers and other stakeholders. Finally, we propose avenues for improving the impact of scenarios in decision making.

8.4.1 Engaging stakeholders and identifying policy needs

Identifying and engaging stakeholders in the scenario development process is essential to identify policy options. Encouraging stakeholders to participate in models and scenarios from an early stage fosters mutual understanding, trust and empowers participants toward the assessment goal. A key policy issue is to manage trade-offs and also opportunities for synergies between biodiversity conservation, food security and livelihoods across contrasting social-ecological regions.

'Stakeholders' are any individuals, groups or organizations who affect, or could be affected (whether positively or negatively) by a particular issue and its associated policies, decisions and actions (Grimble & Wellard 1997, Lucas et al. 2010). 'Actors' are active stakeholders influencing the process, while 'Users' are stakeholders who use the products of an assessment, such as decision-makers. The early engagement of stakeholders in scenarios development is crucial to enhance the legitimacy, salience, and credibility of an assessment (Cash et al. 2003; UNEP & IOC-UNESCO 2009). *Legitimacy* means that the relevant stakeholders are included in the assessment and perceive the process as unbiased and meeting standards of political and procedural fairness (Cash et al. 2003; UNEP & IOC-UNESCO 2009, Lucas et al. 2010, Wittmer et al. 2013). *Saliency* means that the assessment must be relevant by addressing problems relevant for the users (instead of, for instance, questions mainly relevant for the researchers), and take into account the ecological, governance or legal context of the issues. *Credibility* means that the stakeholders are willing to accept the results of the assessment.

As number and/or variety of stakeholders increases, conflicts of interest are likely to occur, especially as regards

engagement of private sectors (Hochkirch et al. 2014). Inappropriate selection of stakeholders causes loss of legitimacy by excluding agents of interest groups, decreases relevance and credibility. ‘User needs assessment’ and ‘stakeholder analysis’ are recommended methods to adopt at the beginning of the assessment for the purpose (Hesselink et al. 2007, Grimble & Wellard 1997). Stakeholder analysis is especially useful to ensure that under-represented categories are included, such as the ‘chronic absentees’ or ‘hard-to-reach’ stakeholders (Padovani and Guentner 2007). Stakeholder analysis can be structured into five steps: (1) define the context affected by a decision or action (see Section 2.2); (2) identify all stakeholders at the different scales of the assessment; (3) identify their interests; (4) differentiate and categorize the stakeholders; (5) investigate the relationship between stakeholders. In identifying and recruiting stakeholders, transparency of the process should be kept such that all stakeholders have the opportunity to be heard and to participate (Wittmer et al. 2013).

A range of participatory methods and tools have been proposed to engage stakeholders in co-designing scenarios (Box 8.5). Participatory scenario development can be used to improve the transparency and relevance of policy making, by incorporating demands and information of each stakeholder, and to negotiate outcomes between stakeholders. Models allow for the comparison of multiple options and the easy substitution of alternative assumptions, while also making trade-offs and potential conflicts of interests between stakeholders explicit (Wittmer et al. 2013). Cultural diversity among stakeholders, including indigenous and local communities, may bring up multiple possible interpretations of a situation (Sections 2.2.1 and 7.4.3, Brugnach and Ingram 2012). Stakeholder interactions become essential to create a shared understanding of a situation. In this way, decision choices become the direct product of shared rules, agreements and practices developed from working together (Section 5.3, Brugnach and Ingram 2012). Hence research efforts need to be oriented towards integrating and producing knowledge in an inclusive manner.

A key policy issue is how to manage trade-offs and opportunities for synergies between biodiversity conservation, food security and livelihoods across contrasting social-ecological regions. In particular the research community needs to: i) identify the nature of these trade-offs and synergies across social-ecological systems and regions of the world; ii) identify the key ecosystem services that are at stake in these trade-offs; iii) identify the biophysical and societal drivers that contribute to exacerbating the trade-offs and those that contribute to reducing them; iv) identify opportunities for synergies between biodiversity conservation, food security and livelihoods that are most suitable for particular social-ecological contexts (Klapwijk et al., 2014; Smith et al., 2013; McCarthy et al., 2012).

Box 8.5. Participatory scenario development

Participatory scenario development allows for the integration of stakeholder’s values and visions in the scenario formulation as well as in the framing of scenario assumptions (Börjeson et al., 2006; Shaw et al., 2009; Forrester et al., 2015). There are different approaches for implementing participatory scenarios, ranging from time demanding truly bottom-up processes of storyline development (Carvalho-Ribeiro et al., 2010; Sheppard, 2005) to more expedited approaches such as ‘confronting’ stakeholders with a storyline already developed as prompts for discussion (Van Berkel et al., 2011). Independently of the method used, stakeholders must have the opportunity to represent in the scenario storylines their own interests and knowledge in such a way they feel rewarded by their engagement in the scenario development process (Flyvbjerg, 2001). Because, in general, stakeholders can judge trade-offs and assess the ways by which land change affects their livelihoods; thus, participatory scenarios can play an important role for addressing the linkage gaps between biodiversity, ecosystem services and human well-being (Section 8.3.1.2). Local and regional stakeholders can also provide insights into the role of spatial variation in the delivery of multiple ecosystem services (Van Berkel et al., 2011). Participatory scenarios are therefore particularly well suited for gaining a richer understanding of trade-offs amongst possible biodiversity futures (Carpenter et al., 2006). Despite wide agreement on the advantages of participatory processes, there are also shortcomings related to the effects of ‘powerful’ stakeholders who may strongly influence participatory processes. Implementing participatory scenarios also requires time for resolving conflicts, to account for possible shifts in policy and economic conditions as the participatory process evolves. One of the tools that has proven useful for comprehensive stakeholder engagement is the use of visualization techniques (Vervoort et al., 2010; Appleton and Lovett, 2003), which can improve communication efficacy by setting everyone’s mind in the same context see 8.4.3.1).

Local communities and indigenous peoples have a wealth of traditional knowledge and are valuable sources of information (see Sections 4.2.3 and 7.3.2 (Pert et al., 2015)). In these communities, the knowledge of the ecosystems and their resource use and conservation practices are related to cultural aspects and religious beliefs (Section 7.4.3, Gadgil et al. (1993)). Hence, they may not trust persons outside their community sufficiently to share their knowledge. Overcoming this requires the development of participation channels through the work of anthropologists and social scientists. Efforts should be made to systematically gather and organize such information. There are some lessons to be learned from climate science and efforts to include traditional ecological knowledge in mitigation and adaptation strategies (Dewulf et al., 2005; Smith and Sharp, 2012; Brugnach et al., 2014). IPBES Deliverable 1c is set to provide guidance on procedures, approaches and participatory processes for working with indigenous and local knowledge systems, while IPBES Deliverable 1c considers different approaches as well as procedures for working with indigenous and local knowledge in assessments of biodiversity and ecosystem services. It is clear that research is needed on developing robust methods to elicit local and indigenous knowledge that are, in many situations, key to the development of models and scenarios (Hesselink et al., 2007).

8.4.2 Linking models to policy options in scenarios

Short-term scenarios can be used to assess policies that act on direct drivers. Long-term scenarios are needed to assess policies that act on indirect drivers or to assess long trajectories of direct drivers. Regional IPBES assessments can use short-term scenarios or existing long-term socio-economic scenarios. The global IPBES assessment could foster a new generation of long term scenarios.

Scenarios can be developed using a variety of approaches (Kok et al., 2011; Alcamo, 2001). We can classify scenarios into two broad classes: exploratory scenarios and policy intervention scenarios (Section 1.3.2; Section 3.2.2). In exploratory scenarios, the analysis starts in the present and different plausible future trajectories are explored by stakeholders, often across major axes of uncertainty on social-ecological dynamics, and using associated narratives for the unfolding of events from present to the future (Kok et al., 2011; Alcamo, 2001). Exploratory scenarios are often associated with the problem identification stage of the policy cycle (Section 3.2.2), and examples include the Millennium Ecosystem Assessment and the Intergovernmental Panel on Climate Change (IPCC) Special Report on Emissions Scenarios (SRES). In policy intervention scenarios, the goal is to assess how specific policy interventions will change the social-ecological trajectories or futures (Van Vuuren et al., 2012b). They can be further divided into target-seeking scenarios and policy-screening scenarios. In target-seeking scenarios, stakeholders agree on a desirable future, and then perform a back casting analysis to identify policy interventions that may lead to the target future (Kok et al., 2011). For example, the Roads from Rio+20 Scenarios (Van Vuuren et al., 2012a) defined a vision for biodiversity in 2050, and then examined three pathways, each one with its own set of policy options, that can lead to that vision. In policy-screening scenarios, a policy or a set of policies are applied and an assessment of how those policies modifies the future is carried out. For instance, the Rethinking Global Biodiversity Strategies scenarios (Ten Brink et al., 2010) consider a set of policy options aimed at reducing biodiversity loss, such as increase in protected areas, changes in diet and improving forest management. The effects on biodiversity of the implementation of those options are then assessed over time.

Exploratory scenarios foster creative thinking and exchange of viewpoints between different stakeholders, but do not always provide clear actions that decision-makers should implement to reach desirable outcomes. Policy intervention scenarios are more likely to provide clear policy pathways but have been criticized for being value laden. Some scenario exercises have tried to combine elements of both approaches (Kok et al., 2011). The scenarios used in the 5th Assessment Report of the IPCC defined plausible relative concentration pathways (RCPs) of greenhouse gases to achieve different target levels of radiative forcing for the end of the century (Moss et al., 2010; Van Vuuren and Carter, 2014). Then, emission pathways and a range of exploratory socio-economic pathways (SSP) were developed (Van Vuuren and Carter, 2014).

Scenarios can also be classified according to their temporal horizon into short-term (e.g., up to a decade) and long-term (decades to a century), addressing different policy development needs (Leadley et al., 2014). Long-term scenarios are useful for assessing policies that act on indirect drivers, such as population growth, with dynamics that play out over large time scales and which impact direct drivers, such as land use change. For instance, a change in fertility rates today will have the most noticeable demographic impacts in a generation. Those changes will then impact the long-term future trajectory of land-use requirements to feed the population, which in turn will impact biodiversity and nature's benefits over those long time scales (Pereira et al., 2010). In some instances it is the biophysical system that has slow dynamics or time lags. For instance, the dynamics of the climate system are so slow that only long term analysis can provide meaningful projections of the climate impacts of current policy changes in fossil fuel use (see Table 8.3).

Table 8.3

Policy applications and development pathways for long-term and short-term scenarios

Type of scenario	Policy application	Options available for development
Long-term scenarios	a) Assessing policies that act on indirect drivers b) Exploring possible futures	i) Use existing indirect driver and/or direct drivers scenarios, and project impacts on biodiversity and ecosystem services. Feasible for regional assessments. ii) Develop scenarios for indirect drivers associated with uncertainties or specific policies and carry out full modelling cycle. Feasible for the global assessment.
Short-term scenarios	Assessing short-term policies on direct drivers.	Model direct driver impacts on biodiversity and ecosystem services under different policies. Users may only want to know endpoints, not the trajectories.

We can envision two different approaches to develop long-term scenarios in IPBES assessments (Table 8.3). One approach is to develop novel socioeconomic scenarios and carry out the complete modelling cycle from indirect to direct drivers, to biodiversity and finally to ecosystem services (Pereira et al., 2010). The socio-economic scenarios could be developed around uncertainties on drivers which are relevant for biodiversity and ecosystem services (corresponding to exploratory scenarios), or with specific policies on indirect drivers with impacts on biodiversity and ecosystem services, including those related to sustainable development goals (SDGs) (corresponding to policy intervention scenarios). This approach would be feasible for the global assessment, but the scenario development would likely start before the beginning of the global assessment as the full scenario development cycle can take up to 5 years, a bit longer than the length planned for the global assessment. This approach would also allow for closing of the feedback loop from ecosystem services to human well-being to indirect drivers in the scenario development (Pereira et al., 2010).

A simpler and faster approach, that could be used by the regional assessments, is to resort to existing long-term scenarios for indirect drivers or socio-economic pathways (e.g., Millennium Ecosystem Assessment (MA), IPCC SSP). Policies to be assessed could be matched to the different pathways (e.g., a policy promoting low fertility would be matched with a MA or IPCC scenario where fertility is low). In some cases existing projection of direct drivers (e.g., land-use change or climate change) associated with those pathways can be used to assess impacts on biodiversity and ecosystem services using models or expert knowledge and downscaling techniques (Sleeter et al., 2012; Walz et al., 2014). Downscaling existing global projections to the regional scale can improve the spatial resolution of the projections and their relevance for the analysis of biodiversity impacts and decision support (Section 6.4.1).

Short-term scenarios can also be useful for assessing how policies on direct drivers affect biodiversity and ecosystem services in the short-term (Leadley et al., 2014). Short-term scenarios do not require modelling the temporal dynamics of indirect drivers or of their impacts on direct drivers. Instead they use simple projections of direct drivers under different policies or actions (corresponding to target-seeking or policy screening scenarios) and assess alternative futures for biodiversity and ecosystem services. Trajectories can be irrelevant as users may only want to know endpoints of direct drivers and assess their impacts on biodiversity and nature's benefits. Short-term scenarios can use optimization tools to find the best actions to achieve a given target, models to assess the biodiversity and ecosystem services consequences of different land-use configurations, or simple statistical extrapolations under different policies. For instance, in systematic conservation planning, optimization tools are used to find the minimum number of protected sites needed to achieve a given target scenario for biodiversity conservation (Sarkar et al. 2006). Ecosystem service models can be used to assess the impacts of short-term land-use scenarios on ecosystem services (Nemec and Raudsepp-Hearne, 2013). Short-term land-use scenarios can be developed through participatory exercises, using maps, photos, and Geographic Information System (GIS) tools (Carvalho Ribeiro et al., 2013; Van Berkel et al., 2011). Finally, simple extrapolations for future values of biodiversity or ecosystem services indicators under a specific action relative to current trends can be made (Leadley et al., 2014). These range of short-term scenario technique can be useful both for global, regional and sub-regional assessments.

8.4.3 Improving the communication of results

Effective communication of model limitations, assumptions and uncertainties, as well as the implications of model outputs, especially probabilistic ones, is essential for constructive use of models in decision-making.

8.4.3.1 Understanding model outputs and the limitations in their scope

Models results need to be understood within the context of the data and the assumptions. Keohane et al., (2014) identify five plausible principles to guide communication: honesty, precision of scientific findings, audience relevance, process transparency, and, specification of uncertainty about conclusions. It is particularly important that the process of building a dialogue between scientists/modellers and stakeholders/decision-makers explicitly involves communicating the weaknesses that inevitably appear regarding present knowledge and the way it can be used. Being clear about what the shortcomings are should permit an increase in the confidence between interlocutors.

Making clear to users what the uncertainties in the output are, what the implications are, and also all that is not implied (Janssen et al., 2005) may have a deep effect on the decision-making process. When users participate in the scenario and model development, they are able to have a better comprehension of the relative value of the output and its meaning because of their previous understanding and involvement in the process. However, when the intended audience was not engaged in the model-construction process, much more attention needs to be given to communicating the outputs in a way that minimizes misinterpretation and does not generate confusion or mistrust. In all cases, the results need to be presented in a clear, consistent, and precise way, giving preference to graphic forms or to tables that summarize the main points.

New technologies in computer science and design have made it easier to represent in a graphical form information on processes and/or data creating a visual image, usually a chart or diagram but also video clips, movement effects and interactive visualizations. These can be efficient means of communicating complex concepts in a clear and simple

way, particularly among actors with different cultural backgrounds. Although scientists usually use sketches and graphs to explain ideas and results in their work environment, they do not normally have any training on how to use these visualization techniques to better report findings to a wider, less specialized audience (McInerny, 2013; McInerny et al., 2014). Infographics and visual representations could be valuable tools to be used from the very beginning of the iterative process of scenarios and model construction and assessment involving scientists and stakeholders, facilitating the understanding of complex processes and identifying uncertainties, and thus building confidence and empowering participants. Moreover, planning of final visual outputs can be embedded into the development and production stage of modelling and scenario activities.

The process of constructing models, proposing scenarios and analysing them as means of learning in advance about the effects and implications of policies on biodiversity and ecosystem services is not only a technical matter. The whole process is embedded in the cultural setting of the societies that are part of those ecosystems and use their resources. Communicating effectively with those stakeholders requires the participation of interdisciplinary professionals with diverse skills and broader intellectual capabilities, in particular social scientists who understand the institutions and the social structure in the region, helping modellers to notice relevant issues, but who can also contribute in helping society better understand and solve environmental problems. The Task Force on Capacity-Building and Task Force on Local and Indigenous Knowledge could consider the proper ways to train and involve interdisciplinary professionals in these communication processes.

8.4.3.2 The importance of communicating uncertainty

A critical challenge in communicating the results of scientific research arises when those results contain uncertainties. It is highly important that the various types of uncertainties that will necessarily appear in the modelling process, as well as in the scenario analysis, be clearly communicated to all stakeholders and decision-makers so that there is full understanding of the relative weight of the output, their implications and the risks involved. Uncertainties need to be set in the context of the key messages that are being conveyed, and the implications of the uncertainties need to be explained. It may also be important to offer information on how the uncertainties can be treated or dealt with. However, decisions can be made even when gaps in information appear, or data are not totally reliable, or ample variability is observed and risks are identified (see Section 8.3.2).

Recent experience, mostly related to the communication of uncertainties related to climate change (Box 8.5) or to potential pandemics, has opened the way to a more systematic analysis of how people perceive the uncertainty inherent to scientific research. These problems have captured the attention of both climate and social scientists (Janssen et al., 2005; Handmer and Proudley, 2007; Klopogge et al., 2007; Pidgeon and Fischhoff, 2011). Research communities have emerged in which people from different fields, such as climate and environmental scientists, historians, social scientists and philosophers, examine issues of uncertainty with respect to global environmental problems with the purpose of improving the capacity to discuss and weigh related policy recommendations (e.g., www.princeton.edu/piirs/research-communities/communicating-uncertainty/).

Box 8.5: An example of the importance of communicating uncertainty in a science-policy interface.

Keohane et al. (2014) focus on the ethics of scientists' communication with policy makers on issues such as climate change. As a case study, they analyse the treatment of possible sea-level rise as a result of melting of ice sheets in Antarctica and Greenland in the Fourth Assessment of the IPCC. Sea-level rise can be projected using computer simulations of global climate models and focusing on three processes: thermal expansion of the oceans, mountain glacier melt, and ice sheet disintegration via melting and dynamical loss (or sliding of ice sheets into the ocean). Sliding is considered the major contributing factor in Antarctica; however, scientists did not have models to estimate future changes in sliding which resulted in a high degree of uncertainty in the projections. The IPCC Working Group I assessing the physical scientific aspects of the climate system and climate change (IPCC, 2007) gave uneven treatment to this third factor relative to the other two, creating confusion with projections lacking clarity and transparency. This led to significant differences in the estimation of sea-level rise to be used in infrastructure planning by coastal communities, making it difficult to take practical, long-term steps under a risk-based approach. It can also be noted that Working Group I and Working Group II (assessing impacts, vulnerability, and adaptation) chose different approaches to deal with uncertainty.

The IPCC has provided guidance on consistent treatment of uncertainties in a unified language (Mastrandrea et al., 2010, <https://www.ipcc.ch/pdf/supporting-material/uncertainty-guidance-note.pdf>), consisting of two metrics for communicating the degree of certainty in key findings. First, theory, data, models and expert judgment can be presented qualitatively in terms of confidence in their validity ('limited', 'medium', or 'robust') and in terms of the degree of agreement ('low', 'medium', or 'high'). Second, uncertainty in a finding can be expressed quantitatively, in terms of probabilities. Following the 'Guide on production and integration of assessments from and across all scales' (IPBES Deliverable 2a), IPBES assessments are encouraged to express their findings using a four-box model of confidence based on evidence and agreement that gives four main confidence terms: 'well established' (much evidence and high agreement), 'unresolved' (much evidence but low agreement), 'established but incomplete' (limited evidence but good agreement) and 'speculative' (limited or no evidence and little agreement).

8.4.3.3 The need to improve the communication of probabilistic results

All biological dynamical systems evolve under stochastic forces. In a stochastic or random process there is some indeterminacy, which is a third type of uncertainty differing from scientific and linguistic uncertainty. Even if the initial condition or starting point is known, there are several directions in which the process may evolve. Translating the meaning of output from stochastic models to persons without professional or specialized knowledge in the subject often generates confusion because there is a whole set of possible outcomes and the results are given in terms either of averages or probabilities. As mentioned earlier, and depending on the context, it is advisable to use multiple models, of differing complexities and types, to compare the outputs and help comprehend their meaning.

Information involving probabilities is often susceptible to biases and misinterpretations, as people have different perceptions of what is really meant. For instance, different levels of comprehension of weather forecasts given in probabilistic terms were detected depending on gender and age (Handmer and Proudley, 2007). Social and cultural factors may influence the interpretation of the probability of occurrence of a given outcome and the perception of the seriousness of possible non-desirable consequences. Research on cognitive biases and prospect theory (behavioural economic theory that describes the way people choose between probabilistic alternatives that involve risk) indicates that people have difficulty in correctly interpreting risks because they are more likely to act to avoid a loss than to achieve a gain (Kahneman and Tversky, 1979; Kahneman et al., 1982; Kahneman, 2011). IPBES Deliverable 2a takes this into account when pointing to the fact that the way in which a statement is framed will have an effect on how it is interpreted; for instance, a 10% chance of dying is interpreted more negatively than a 90% chance of surviving. Hence, when assessing and communicating confidence for Executive Summaries and Summaries for Policy Makers, it recommends considering reciprocal statements to avoid value-laden interpretations. It is advisable that the Task Force on Capacity-Building encourages further research on cognitive processes that may help improve the communication of more precise information regarding uncertainties and risks in a probabilistic format.

8.4.4 From scenarios to decision-making

The process whereby stakeholders engage in a scenarios assessment includes the definition of the relevant variables, assumptions, methods and parameterization, all the way to communicating results, uncertainties and caveats, in the appropriate language, to different audiences (Cash et al., 2003; Folke et al., 2005). There is a variety of science-policy interfaces that enable the two-way communication between scientists and stakeholders needed for a scenarios assessment (Chapason and van den Hove, 2009). The most successful of these science-policy interfaces have some institutional way of facilitating or enabling the aforementioned functions over the long periods of time that are often necessary for effective communication. Such institutions have been called boundary or bridging institutions (Cash et al., 2003; Folke et al., 2005; Cash et al., 2006).

The role of bridging institutions in facilitating the science to policy process is crucial given the multiscale features of most realistic biodiversity-governance problems, the variety of stakeholders (Section 8.4.1), and the serious problem of communicating the assumptions and the results of ‘boundary objects’ (Section 8.4.3) such as scenarios. Boundary objects are collaborative products that are both adaptable to different viewpoints, and therefore commonly recognized, and relevant for different actors and robust enough to maintain identity across them (Clark et al., 2011). Besides scenarios, other examples of boundary objects are conceptual frameworks, models and reports (Hauck et al., 2014).

Boundary objects resulting from a science to policy process should be communicated actively using the right translation of terms, and concepts, and, if needed, a mediation between stakeholders with different languages, usages and histories (Cash et al., 2003). Such demanding and complicated tasks are better performed institutionally. An institution is more likely than individuals to develop the credibility, memory and experience needed to facilitate the process of developing appropriate boundary objects. Bridging institutions such as IPBES and IPCC can create the conditions not only for the development of boundary objects but also for the uptake of those boundary objects by decision-makers and other stakeholders. Bridging institutions can also demonstrate the benefits and use of scenarios assessments, so that models and scenarios are more widely used in decision making in a variety of contexts.

In this chapter we provided an overview of the multiple aspects of the scenario development cycle and the underlying dialog between data and model which are amenable for improvement (see summary in Box 8.6). Ultimately, it is up to scientists and all stakeholders to bring these ideas to fruition in order to improve decision-making processes related to the management of biodiversity and ecosystem services.

Box 8.6: Summary of key issues to improve scenarios.

In order to increase the uptake of models and scenarios in decision-making processes, assessments should:

- Identify key global biodiversity and ecosystem services problems and questions to which they can develop effective and robust answers;
- Overcome disciplinary barriers in modelling, data collection, selection and management;
- Identifying co-design and co-development of best practices that respond to policy needs;

- Define, develop, and improve modelling and scenario development methodologies appropriate for the different social contexts and policy needs;
- Identifying robust model integration and validation techniques that respond to current and future development requirements;
- Establish a permanent dialogue between modellers, scenario developers, and decision-makers to address issues such as common understanding of concepts, transdisciplinarity, and infrastructure for resource and knowledge sharing;
- Encourage transdisciplinary research leading to a clearer, effective, and broader communication of model and scenario outputs as well as communication of uncertainties within the cultural context of the human societies involved.

References

- Alcamo, J., 2001: Scenarios as tools for international environmental assessments. European Environment Agency, Environmental issue report 24, Luxembourg.
- Alkemade, R., Van Oorschot, M., Miles, L., Nellemann, C., Bakkenes, M. and ten Brink, B., 2009: GLOBIO3: A Framework to Investigate Options for Reducing Global Terrestrial Biodiversity Loss. *Ecosystems*, **12**(3): 374-390.
- Appleton, K. and Lovett, A., 2003: GIS-based visualisation of rural landscapes: defining 'sufficient' realism for environmental decision-making. *Landscape and Urban Planning*, **65**: 117-131.
- Baillie, J.E.M., Collen, B., Amin, R., Akcakaya, H.R., Butchart, S.H.M., Brummitt, N., Meagher, T.R., Ram, M., Hilton-Taylor, C. and Mace, G.M., 2008: Toward monitoring global biodiversity. *Conservation Letters*, **1**(1): 18-26.
- Bateman, I.J., Harwood, A.R., Mace, G.M., Watson, R.T., Abson, D.J., Andrews, B., Binner, A., Crowe, A., Day, B.H., Dugdale, S., Fezzi, C., Foden, J., Hadley, D., Haines-Young, R., Hulme, M., Kontoleon, A., Lovett, A.A., Munday, P., Pascual, U., Paterson, J., Perino, G., Sen, A., Siriwardena, G., van Soest, D. and Termansen, M., 2013: Bringing Ecosystem Services into Economic Decision-Making: Land Use in the United Kingdom. *Science*, **341**(6141): 45-50.
- Benson, B.J., Bond, B.J., Hamilton, M.P., Monson, R.K. and Han, R., 2009: Perspectives on next-generation technology for environmental sensor networks. *Frontiers in Ecology and the Environment*, **8**(4): 193-200.
- Bontemps, S., Herold, M., Kooistra, L., van Groenestijn, A., Hartley, A., Arino, O., Moreau, I. and Defourny, P., 2011: Revisiting land cover observations to address the needs of the climate modelling community. *Biogeosciences Discussions*, **8**: 7713-7740.
- Borgman, C.L., 2012: The conundrum of sharing research data. *Journal of the American Society for Information Science and Technology*, **63**(6): 1059-1078.
- Börjeson, L., Höjer, M., Dreborg, K.-H., Ekvall, T. and Finnveden, G., 2006: Scenario types and techniques: towards a user's guide. *Futures*, **38**(7): 723-739.
- Brandt, P., Abson, D.J., DellaSala, D.A., Feller, R. and von Wehrden, H., 2014: Multifunctionality and biodiversity: Ecosystem services in temperate rainforests of the Pacific Northwest, USA. *Biological Conservation*, **169**: 362-371.
- Brook, B.W., O'Grady, J.J., Chapman, A.P., Burgman, M.A., Akçakaya, H.R. and Frankham, R., 2000: Predictive accuracy of population viability analysis in conservation biology. *Nature*, **404**(6776): 385-387.
- Brooks, T. and Kennedy, E., 2004: Conservation biology: biodiversity barometers. *Nature*, **431**(7012): 1046-1047.
- Bruognach, M., Craps, M. and Dewulf, A., 2014: Including indigenous peoples in climate change mitigation: addressing issues of scale, knowledge and power. *Climatic Change*: 1-14.
- Buchanan, G.M., Nelson, A., Mayaux, P., Hartley, A. and Donald, P.F., 2009: Delivering a global, terrestrial, biodiversity observation system through remote sensing. *Conservation Biology*, **23**(2): 499-502.
- Buckland, S.T., Magurran, A.E., Green, R.E. and Fewster, R.M., 2005: Monitoring change in biodiversity through composite indices. *Philosophical Transactions of the Royal Society B: Biological Sciences*, **360**(1454): 243.
- Butchart, S.H.M., Stattersfield, A.J., Bennun, L.A., Shutes, S.M., Akçakaya, H.R., Baillie, J.E.M., Stuart, S.N., Hilton-Taylor, C. and Mace, G.M., 2004: Measuring Global Trends in the Status of Biodiversity: Red List Indices for Birds. *PLoS Biology*, **2**(12): e383.
- Butchart, S.H.M., Walpole, M., Collen, B., van Strien, A., Scharlemann, J.P.W., Almond, R.E.A., Baillie, J.E.M., Bomhard, B., Brown, C., Bruno, J., Carpenter, K.E., Carr, G.M., Chanson, J., Chenery, A.M., Csirke, J., Davidson, N.C., Dentener, F., Foster, M., Galli, A., Galloway, J.N., Genovesi, P., Gregory, R.D., Hockings, M., Kapos, V., Lamarque, J.-F., Leverington, F., Loh, J., McGeoch, M.A., McRae, L., Minasyan, A., Morcillo, M.H., Oldfield, T.E.E., Pauly, D., Quader, S., Revenga, C., Sauer, J.R., Skolnik, B., Spear, D., Stanwell-Smith, D., Stuart, S.N., Symes, A., Tierney, M., Tyrrell, T.D., Vie, J.-C. and Watson, R., 2010: Global Biodiversity: Indicators of Recent Declines. *Science*, **328**(5982): 1164-1168.
- Carpenter, S.R., De Fries, R., Dietz, T., Mooney, H.A., Polasky, S., Reid, W.V. and Scholes, R.J., 2006: Millennium ecosystem assessment: research needs. *Science*, **314**: 257-258.
- Carvalho-Ribeiro, S.M., Lovett, A. and O'Riordan, T., 2010: Multifunctional forest management in Northern Portugal: Moving from scenarios to governance for sustainable development. *Land Use Policy*, **27**(4): 1111-1122.

- Carvalho Ribeiro, S., Migliozi, A., Incerti, G. and Pinto Correia, T., 2013: Placing land cover pattern preferences on the map: Bridging methodological approaches of landscape preference surveys and spatial pattern analysis. *Landscape and Urban Planning*, **114**: 53-68.
- Cash, D.W., Clark, W.C., Alcock, F., Dickson, N.M., Eckley, N., Guston, D.H., Jäger, J. and Mitchell, R.B., 2003: Knowledge systems for sustainable development. *Proceedings of The National Academy of Sciences*, **100**(14): 8086-8091.
- Cash, D.W., Adger, W.N., Berkes, F., Garden, P., Lebel, L., Olsson, P., Pritchard, L. and Young, O., 2006: Scale and cross-scale dynamics: governance and information in a multilevel world. *Ecology and Society*, **11**(2): 8.
- CBD, 2015: Report of the Ad-Hoc Technical Expert Group on Indicators for the Strategic Plan for Biodiversity 2011-2020. Secretariat of the Convention on Biological Diversity,
- Chapason, L. and van den Hove, S., 2009: The Debate on an intergovernmental science-policy platform on biodiversity and ecosystem services (IPBES): Exploring gaps and needs. *Iddri - Idées pour le débat*, (01).
- Christensen, V. and Walters, C.J., 2004: Ecopath with Ecosim: methods, capabilities and limitations. *Ecological Modelling*, **172**(2-4): 109-139.
- Clark, W.C., Tomich, T.P., van Noordwijk, M., Guston, D., Catacutan, D., Dickson, N.M. and McNie, E., 2011: Boundary work for sustainable development: Natural resource management at the Consultative Group on International Agricultural Research (CGIAR). *Proceedings of The National Academy of Sciences*, **10**: 1073.
- Collen, B., Loh, J., Whitmee, S., McRae, L., Amin, R. and Baillie, J.E.M., 2009: Monitoring Change in Vertebrate Abundance: the Living Planet Index. *Conservation Biology*, **23**(2): 317-327.
- Collins, S.L., Bettencourt, L.M.A., Hagberg, A., Brown, R.F., Moore, D.I., Bonito, G., Delin, K.A., Jackson, S.P., Johnson, D.W., Burleigh, S.C., Woodrow, R.R. and McAuley, J.M., 2006: New opportunities in ecological sensing using wireless sensor networks. *Frontiers in Ecology and the Environment*, **4**(8): 402-407.
- Costello, M.J., Michener, W.K., Gahegan, M., Zhang, Z.-Q. and Bourne, P.E., 2013: Biodiversity data should be published, cited, and peer reviewed. *Trends in Ecology & Evolution*, **28**(8): 454-461.
- Daily, G.C., Polasky, S., Goldstein, J., Kareiva, P.M., Mooney, H.A., Pejchar, L., Ricketts, T.H., Salzman, J. and Shallenberger, R., 2009: Ecosystem services in decision making: time to deliver. *Frontiers in Ecology and the Environment*, **7**(1): 21-28.
- Damuth, J., 1987: Interspecific allometry of population density in mammals and other animals: the independence of body mass and population energy-use. *Biological Journal of the Linnean Society*, **31**(3): 193-246.
- Dewulf, A., Craps, M., Bouwen, R., Abril, F. and Zhingri, M., 2005: How indigenous farmers and university engineers create actionable knowledge for sustainable irrigation. *Action research*, **3**(2): 175-192.
- Di Marco, M., Cardillo, M., Possingham, H.P., Wilson, K.A., Blomberg, S.P., Boitani, L. and Rondinini, C., 2012: A novel approach for global mammal extinction risk reduction. *Conservation Letters*, **5**(2): 134-141.
- Díaz, S., Demissew, S., Carabias, J., Joly, C., Lonsdale, M., Ash, N., Larigauderie, A., Adhikari, J.R., Arico, S., Báldi, A., Bartuska, A., Baste, I.A., Bilgin, A., Brondizio, E., Chan, K.M.A., Figueroa, V.E., Duraipappah, A., Fischer, M., Hill, R., Koetz, T., Leadley, P., Lyver, P., Mace, G.M., Martin-Lopez, B., Okumura, M., Pacheco, D., Pascual, U., Pérez, E.S., Reyers, B., Roth, E., Saito, O., Scholes, R.J., Sharma, N., Tallis, H., Thaman, R., Watson, R., Yahara, T., Hamid, Z.A., Akosim, C., Al-Hafedh, Y., Allahverdiyev, R., Amankwah, E., Asah, S.T., Asfaw, Z., Bartus, G., Brooks, L.A., Caillaux, J., Dalle, G., Darnaedi, D., Driver, A., Erpul, G., Escobar-Eyzaguirre, P., Failler, P., Fouda, A.M.M., Fu, B., Gundimeda, H., Hashimoto, S., Homer, F., Lavorel, S., Lichtenstein, G., Mala, W.A., Mandivenyi, W., Matczak, P., Mbizvo, C., Mehrdadi, M., Metzger, J.P., Mikissa, J.B., Moller, H., Mooney, H.A., Mumby, P., Nagendra, H., Nesshover, C., Oteng-Yeboah, A.A., Pataki, G., Roué, M., Rubis, J., Schultz, M., Smith, P., Sumaila, R., Takeuchi, K., Thomas, S., Verma, M., Yeo-Chang, Y. and Zlatanova, D., 2015: The IPBES Conceptual Framework — connecting nature and people. *Current opinion in environmental sustainability*, **14**: 1-16.
- EC, 2014: Mapping and Assessment of Ecosystems and their Services: Indicators for ecosystem assessments under Action 5 of the EU Biodiversity Strategy 2020. European Commission, Technical Report 080,
- Egoh, B., Drakou, E.G., Dunbar, M.B., Maes, J. and Willemsen, L., 2012: Indicators for mapping ecosystem services: a review. European Commission, Joint Research Centre, Ispra, Italy.
- Flyvbjerg, B., 2001: *Making social science matter: Why social inquiry fails and how it can succeed again*. Cambridge university press.
- Folke, C., Hahn, T., Olsson, P. and Norberg, J., 2005: Adaptive governance of social-ecological systems. *Annu. Rev. Environ. Resour.*, **30**: 441-473.

- Forrester, J., Cook, B., Bracken, L., Cinderby, S. and Donaldson, A., 2015: Combining participatory mapping with Q-methodology to map stakeholder perceptions of complex environmental problems. *Applied Geography*, **56**: 199-208.
- Gadgil, M., Berkes, F. and Folke, C., 1993: Indigenous Knowledge for Biodiversity Conservation. *AMBIO: A journal of the human environment*, **22**(2-3): 151-156.
- Guisan, A. and Thuiller, W., 2005: Predicting species distribution: offering more than simple habitat models. *Ecology Letters*, **8**(9): 993-1009.
- Handmer, J. and Proudley, B., 2007: Communicating uncertainty via probabilities: The case of weather forecasts. *Environmental Hazards*, **7**(2): 79-87.
- Hansen, M.C., Potapov, P.V., Moore, R., Hancher, M., Turubanova, S.A., Tyukavina, A., Thau, D., Stehman, S.V., Goetz, S.J., Loveland, T.R., Kommareddy, A., Egorov, A., Chini, L., Justice, C.O. and Townshend, J.R.G., 2013: High-Resolution Global Maps of 21st-Century Forest Cover Change. *Science*, **342**(6160): 850-853.
- Harfoot, M.B.J., Newbold, T., Tittensor, D.P., Emmott, S., Hutton, J., Lyutsarev, V., Smith, M.J., Scharlemann, J.P.W. and Purves, D.W., 2014: Emergent Global Patterns of Ecosystem Structure and Function from a Mechanistic General Ecosystem Model. *PLoS Biology*, **12**(4): e1001841.
- Hauck, J., Albert, C., Fürst, C., Geneletti, D., La Rosa, D., Lorz, C. and Spyra, M., 2016: Developing and applying ecosystem service indicators in decision-support at various scales. *Ecological Indicators*, **61**, Part 1: 1-5.
- Hauck, J., Görg, C., Werner, A., Jax, K., Bidoglio, G., Maes, J., Furman, E. and Ratamáki, O., 2014: Transdisciplinary Enrichment of a Linear Research Process: Experiences Gathered from a Research Project Supporting the European Biodiversity Strategy to 2020. *Interdisciplinary Science Reviews*, **39**(4): 376-391.
- Hesselink, F., Goldstein, W., van Kempen, P.P., Garnett, T. and Dela, J., 2007: Communication, Education and Public Awareness (CEPA) A toolkit for National Focal Points and NBSAP Coordinators. Secretariat of the Convention on Biological Diversity and IUCN, Montreal, Canada.
- Hobern, D., Apostolico, A., Arnaud, E., Bello, J.C., Canhos, D., Dubois, G., Field, D., Alonso Garcia, E., Hardisty, A., Harrison, J. and others, 2013: *Global biodiversity informatics outlook: delivering biodiversity knowledge in the information age*. Global Biodiversity Information Facility (Secretariat).
- Hudson, L.N., Newbold, T., Contu, S., Hill, S.L.L., Lysenko, I., De Palma, A., Phillips, H.R.P., Senior, R.A., Bennett, D.J., Booth, H., Choimes, A., Correia, D.L.P., Day, J., Echeverría-Londoño, S., Garon, M., Harrison, M.L.K., Ingram, D.J., Jung, M., Kemp, V., Kirkpatrick, L., Martin, C.D., Pan, Y., White, H.J., Aben, J., Abrahamczyk, S., Adum, G.B., Aguilar-Barquero, V., Aizen, M.A., Ancrenaz, M., Arbeláez-Cortés, E., Armbrrecht, I., Azhar, B., Azpiroz, A.B., Baeten, L., Báldi, A., Banks, J.E., Barlow, J., Batáry, P., Bates, A.J., Bayne, E.M., Beja, P., Berg, Á., Berry, N.J., Bicknell, J.E., Bihn, J.H., Böhning-Gaese, K., Boekhout, T., Boutin, C., Bouyer, J., Brearley, F.Q., Brito, I., Brunet, J., Buczkowski, G., Buscardo, E., Cabra-García, J., Calviño-Cancela, M., Cameron, S.A., Cancellato, E.M., Carrijo, T.F., Carvalho, A.L., Castro, H., Castro-Luna, A.A., Cerda, R., Cerezo, A., Chauvat, M., Clarke, F.M., Cleary, D.F.R., Connop, S.P., D'Aniello, B., da Silva, P.G., Darvill, B., Dauber, J., Dejean, A., Diekötter, T., Dominguez-Haydar, Y., Dormann, C.F., Dumont, B., Dures, S.G., Dynesius, M., Edenius, L., Elek, Z., Entling, M.H., Farwig, N., Fayle, T.M., Felicioli, A., Felton, A.M., Ficetola, G.F., Filgueiras, B.K.C., Fonte, S.J., Fraser, L.H., Fukuda, D., Furlani, D., Ganzhorn, J.U., Garden, J.G., Gheler-Costa, C., Giordani, P., Giordano, S., Gottschalk, M.S., Goulson, D., Gove, A.D., Grogan, J., Hanley, M.E., Hanson, T., Hashim, N.R., Hawes, J.E., Hébert, C., Helden, A.J., Henden, J.-A., Hernández, L., Herzog, F., Higuera-Diaz, D., Hilje, B., Horgan, F.G., Horváth, R., Hylander, K., Isaacs-Cubides, P., Ishitani, M., Jacobs, C.T., Jaramillo, V.J., Jauker, B., Jonsell, M., Jung, T.S., Kapoor, V., Kati, V., Katovai, E., Kessler, M., Knop, E., Kolb, A., Kőrösi, Á., Lachat, T., Lantschner, V., Le Féon, V., LeBuhn, G., Légaré, J.-P., Letcher, S.G., Littlewood, N.A., López-Quintero, C.A., Louhaichi, M., Lövei, G.L., Lucas-Borja, M.E., Luja, V.H., Maeto, K., Magura, T., Mallari, N.A., Marin-Spiotta, E., Marshall, E.J.P., Martínez, E., Mayfield, M.M., Mikusinski, G., Milder, J.C., Miller, J.R., Morales, C.L., Muchane, M.N., Muchane, M., Naidoo, R., Nakamura, A., Naoe, S., Nates-Parra, G., Navarrete Gutierrez, D.A., Neuschulz, E.L., Noreika, N., Norfolk, O., Noriega, J.A., Nöske, N.M., O'Dea, N., Oduro, W., Ofori-Boateng, C., Oke, C.O., Osgathorpe, L.M., Paritsis, J., Parra-H, A., Pelegrin, N., Peres, C.A., Persson, A.S., Petanidou, T., Phalan, B., Phillips, T.K., Poveda, K., Power, E.F., Presley, S.J., Proença, V., Quaranta, M., Quintero, C., Redpath-Downing, N.A., Reid, J.L., Reis, Y.T., Ribeiro, D.B., Richardson, B.A., Richardson, M.J., Robles, C.A., Römbke, J., Romero-Duque, L.P., Rosselli, L., Rossiter, S.J., Roulston, T.a.H., Rousseau, L., Sadler, J.P., Sáfián, S., Saldaña-Vázquez, R.A., Samnegård, U., Schüepp, C., Schweiger, O., Sedlock, J.L., Shahabuddin, G., Sheil, D., Silva, F.A.B., Slade, E.M., Smith-Pardo, A.H., Sodhi, N.S., Somarriba, E.J., Sosa, R.A., Stout, J.C., Struebig, M.J., Sung, Y.-H., Threlfall, C.G., Toniello, R., Tóthmérész, B., Tschardtke, T., Turner, E.C., Tylianakis, J.M., Vanbergen, A.J., Vassilev, K., Verboven, H.A.F., Vergara, C.H., Vergara, P.M., Verhulst, J., Walker, T.R., Wang, Y., Watling, J.I., Wells, K.,

- Williams, C.D., Willig, M.R., Woinarski, J.C.Z., Wolf, J.H.D., Woodcock, B.A., Yu, D.W., Zaitsev, A.S., Collen, B., Ewers, R.M., Mace, G.M., Purves, D.W., Scharlemann, J.P.W. and Purvis, A., 2014: The PREDICTS database: a global database of how local terrestrial biodiversity responds to human impacts. *Ecology and Evolution*, **4**(24): 4701-4735.
- Hurttt, G.C., Chini, L.P., Frothing, S., Betts, R.A., Feddema, J., Fischer, G., Fisk, J.P., Hibbard, K., Houghton, R.A., Janetos, A., Jones, C.D., Kindermann, G., Kinoshita, T., Klein Goldewijk, K., Riahi, K., Shevliakova, E., Smith, S., Stehfest, E., Thomson, A., Thornton, P., van Vuuren, D.P. and Wang, Y.P., 2011: Harmonization of land-use scenarios for the period 1500–2100: 600 years of global gridded annual land-use transitions, wood harvest, and resulting secondary lands. *Climatic Change*, **109**(1-2): 117-161.
- IPCC, 2007: Summary for policymakers. Cambridge University Press, Climate Change 2007: The Physical Science Basis. Contribution of Working Group I to the Fourth Assessment Report of the Intergovernmental Panel on Climate Change [Stocker, T.F., D. Qin, G.-K. Plattner, M. Tignor, S.K. Allen, J. Boschung, A. Nauels, Y. Xia, V. Bex and P.M. Midgley (eds.)]. Cambridge, United Kingdom and New York, NY, USA.
- Janssen, P.H.M., Petersen, A.C., van der Sluijs, J.P., Risbey, J.S. and Ravetz, J.R., 2005: A guidance for assessing and communicating uncertainties. *Water science and technology*, **52**(6): 125-134.
- Jetz, W., McPherson, J.M. and Guralnick, R.P., 2012: Integrating biodiversity distribution knowledge: toward a global map of life. *Trends in Ecology & Evolution*, **27**(3): 151-159.
- Kahneman, D., 2011: *Thinking, fast and slow*. New York, Farrar, Straus and Giroux.
- Kahneman, D. and Tversky, A., 1979: Prospect theory: An analysis of decision under risk. *Econometrica*, **47**(2): 263.
- Kahneman, D., Slovic, P. and Tversky, A., 1982: *Judgment under Uncertainty: Heuristics and Biases*. New York, Cambridge University Press.
- Karp, D.S., Tallis, H., Sachse, R., Halpern, B., Thonicke, K., Cramer, W., Mooney, H., Polasky, S., Tietjen, B., Waha, K., Walz, A. and Wolny, S., 2015: National indicators for observing ecosystem service change. *Global Environmental Change*, **35**: 12-21.
- Keith, D.A., Akcakaya, H.R., Thuiller, W., Midgley, G.F., Pearson, R.G., Phillips, S.J., Regan, H.M., Araujo, M.B. and Rebelo, T.G., 2008: Predicting extinction risks under climate change: coupling stochastic population models with dynamic bioclimatic habitat models. *Biology Letters*, **4**(5): 560-563.
- Keohane, R.O., Lane, M. and Oppenheimer, M., 2014: The ethics of scientific communication under uncertainty. *Politics, Philosophy & Economics*: 343-368.
- Klapwijk, C.J., Van Wijk, M.T., Rosenstock, T.S., Van Asten, P.J.A., Thornton, P.K. and Giller, K.E., 2014: Analysis of trade-offs in agricultural systems: current status and way forward. *Current opinion in environmental sustainability*, **6**: 110-115.
- Kloprogge, P., van der Sluijs, J. and Wardekker, A., 2007: Uncertainty Communication Issues and good practice. Copernicus Institute for Sustainable Development and Innovation Department of Science Technology and Society (STS), Utrecht, The Netherlands.
- Kogan, F., Powell, A. and Fedorov, O., 2011: *Use of satellite and in-situ data to improve sustainability*. Springer.
- Kok, K., van Vliet, M., Bärlund, I., Dubel, A. and Sendzimir, J., 2011: Combining participative backcasting and exploratory scenario development: experiences from the SCENES project. *Technological Forecasting and Social Change*, **78**(5): 835-851.
- Landers, D.H. and Nahlik, A.M., 2013: Final ecosystem goods and services classification system (FECS-CS). In EPA United States Environmental Protection Agency. Report number EPA/600/R-13/ORD-004914.
- Layke, C., Mapendembe, A., Brown, C., Walpole, M. and Winn, J., 2012: Indicators from the global and sub-global Millennium Ecosystem Assessments: An analysis and next steps. *Ecological Indicators*, **17**: 77-87.
- Leadley, P.W., Krug, C.B., Alkemade, R., Pereira, H.M., Sumaila, U.R., Walpole, M., Marques, A., Newbold, T., Teh, L.S.L., Van Kolck, J., Bellard, C., Januchowski-Hartley, S.R. and Mumby, P.J., 2014: Progress towards the Aichi Biodiversity Targets: An Assessment of biodiversity Trends, Policy Scenarios and Key Actions. Secretariat of the Convention on Biological Diversity, Technical Series 78, Montreal, Canada.
- Loh, J., Green, R.E., Ricketts, T., Lamoreux, J., Jenkins, M., Kapos, V. and Randers, J., 2005: The Living Planet Index: using species population time series to track trends in biodiversity. *Philosophical Transactions of the Royal Society of London B: Biological Sciences*, **360**(1454): 289-295.
- Lyashevskaya, O. and Farnsworth, K.D., 2012: How many dimensions of biodiversity do we need? *Ecological Indicators*, **18**: 485-492.

- Martín-López, B., Iniesta-Arandia, I., García-Llorente, M., Palomo, I., Casado-Arzuaga, I., Amo, D.G.D., Gómez-Baggethun, E., Oteros-Rozas, E., Palacios-Agundez, I., Willaarts, B., González, J.A., Santos-Martín, F., Onaindia, M., López-Santiago, C. and Montes, C., 2012: Uncovering Ecosystem Service Bundles through Social Preferences. *PLoS ONE*, **7**(6): e38970.
- Martin, L.J., Blossey, B. and Ellis, E., 2012: Mapping where ecologists work: biases in the global distribution of terrestrial ecological observations. *Frontiers in Ecology and the Environment*, **10**(4): 195-201.
- Mastrandrea, M.D., Field, C.B., Stocker, T.F., Edenhofer, O., Ebi, K.L., Frame, D.J., Held, H., Kriegler, E.M., Matschoss, P.R., Plattner, G.K., Yohe, G.W. and Zwiars, F.W., 2010: Guidance Note for Lead Authors of the IPCC Fifth Assessment Report on Consistent Treatment of Uncertainties. Intergovernmental Panel on Climate Change (IPCC).
- McCarthy, N., Lipper, L., Mann, W., Branca, G. and Capaldo, J., 2012: Evaluating synergies and trade-offs among food security, development and climate change. In *Climate Change Mitigation and Agriculture*, Wollenberg, E., Tapio-Bistrom, M.-L., Grieg-Gran, M. and Nihart, A., eds., Routledge, 39-49.
- McInerny, G., 2013: Embedding visual communication into scientific practice. *Trends in Ecology & Evolution*, **1**(28): 13-14.
- McInerny, G.J., Chen, M., Freeman, R., Gavaghan, D., Meyer, M., Rowland, F., Spiegelhalter, D.J., Stefaner, M., Tessarolo, G. and Hortal, J., 2014: Information visualisation for science and policy: engaging users and avoiding bias. *Trends in Ecology & Evolution*, **29**(3): 148-157.
- Michener, W.K. and Jones, M.B., 2012: Ecoinformatics: supporting ecology as a data-intensive science. *Trends in Ecology & Evolution*, **27**(2): 85-93.
- Michener, W.K., Allard, S., Budden, A., Cook, R.B., Douglass, K., Frame, M., Kelling, S., Koskela, R., Tenopir, C. and Vieglais, D.A., 2012: Participatory design of DataONE—enabling cyberinfrastructure for the biological and environmental sciences. *Ecological Informatics*, **11**: 5-15.
- Molloy, J.C., 2011: The open knowledge foundation: open data means better science. *PLoS Biol*, **9**(12): e1001195.
- Moritz, C., Patton, J.L., Conroy, C.J., Parra, J.L., White, G.C. and Beissinger, S.R., 2008: Impact of a century of climate change on small-mammal communities in Yosemite National Park, USA. *Science*, **322**(5899): 261-264.
- Moss, R.H., Edmonds, J.A., Hibbard, K.A., Manning, M.R., Rose, S.K., van Vuuren, D.P., Carter, T.R., Emori, S., Kainuma, M., Kram, T., Meehl, G.A., Mitchell, J.F.B., Nakicenovic, N., Riahi, K., Smith, S.J., Stouffer, R.J., Thomson, A.M., Weyant, J.P. and Wilbanks, T.J., 2010: The next generation of scenarios for climate change research and assessment. *Nature*, **463**(7282): 747-756.
- Nemec, K.T. and Raudsepp-Hearne, C., 2013: The use of geographic information systems to map and assess ecosystem services. *Biodiversity and Conservation*, **22**(1): 1-15.
- Newbold, T., Hudson, L.N., Hill, S.L.L., Contu, S., Lysenko, I., Senior, R.A., Börger, L., Bennett, D.J., Choimes, A., Collen, B., Day, J., De Palma, A., Díaz, S., Echeverria-Londoño, S., Edgar, M.J., Feldman, A., Garon, M., Harrison, M.L.K., Alhusseini, T., Ingram, D.J., Itescu, Y., Kattge, J., Kemp, V., Kirkpatrick, L., Kleyer, M., Correia, D.L.P., Martin, C.D., Meiri, S., Novosolov, M., Pan, Y., Phillips, H.R.P., Purves, D.W., Robinson, A., Simpson, J., Tuck, S.L., Weiher, E., White, H.J., Ewers, R.M., Mace, G.M., Scharlemann, J.P.W. and Purvis, A., 2015: Global effects of land use on local terrestrial biodiversity. *Nature*, **520**(7545): 45-50.
- Nicholson, E., Collen, B., Barausse, A., Blanchard, J.L., Costelloe, B.T., Sullivan, K.M.E., Underwood, F.M., Burn, R.W., Fritz, S., Jones, J.P.G., McRae, L., Possingham, H.P. and Milner-Gulland, E.J., 2012: Making Robust Policy Decisions Using Global Biodiversity Indicators. *PLoS ONE*, **7**(7): e41128.
- Noss, R.F., 1990: Indicators for Monitoring Biodiversity - a Hierarchical Approach. *Conservation Biology*, **4**(4): 355-364.
- Olson, D.M., Dinerstein, E., Wikramanayake, E.D., Burgess, N.D., Powell, G.V.N., Underwood, J.A., Itoua, I., Strand, H.E., Morrison, J.C., Loucks, O.L., Allnut, T.F., Ricketts, T.H., Kura, Y., Lamoreux, J.F., Wettengel, W.W., Hedao, P. and Kassem, K.R., 2001: Terrestrial Ecoregions of the World: A New Map of Life on Earth. *Bioscience*, **51**(11): 933-938.
- Pearson, R.G., Stanton, J.C., Shoemaker, K.T., Aiello-Lammens, M.E., Ersts, P.J., Horning, N., Fordham, D.A., Raxworthy, C.J., Ryu, H.Y., McNees, J. and others, 2014: Life history and spatial traits predict extinction risk due to climate change. *Nature Climate Change*, **4**(3): 217-221.
- Penone, C., Davidson, A.D., Shoemaker, K.T., Di Marco, M., Rondinini, C., Brooks, T.M., Young, B.E., Graham, C.H. and Costa, G.C., 2014: Imputation of missing data in life-history trait datasets: which approach performs the best? *Methods in Ecology and Evolution*, **5**(9): 961-970.

- Pereira, H.M., Navarro, L.M. and Martins, I.S., 2012: Global biodiversity change: the bad, the good, and the unknown. *Annual Review of Environment and Resources*, **37**(1): 25-50.
- Pereira, H.M., Leadley, P.W., Proenca, V., Alkemade, R., Scharlemann, J.P.W., Fernandez-Manjarres, J.F., Araujo, M.B., Balvanera, P., Biggs, R., Cheung, W.W.L., Chini, L., Cooper, H.D., Gilman, E.L., Guénette, S., Hurtt, G.C., Huntington, H.P., Mace, G.M., Oberdorff, T., Revenga, C., Rodrigues, P., Scholes, R.J., Sumaila, U.R. and Walpole, M., 2010: Scenarios for Global Biodiversity in the 21st Century. *Science*, **330**(6010): 1496-1501.
- Pereira, H.M., Ferrier, S., Walters, M., Geller, G.N., Jongman, R.H.G., Scholes, R.J., Bruford, M.W., Brummitt, N., Butchart, S.H.M., Cardoso, A.C., Coops, N.C., Dulloo, E., Faith, D.P., Freyhof, J., Gregory, R.D., Heip, C., Höft, R., Hurtt, G., Jetz, W., Karp, D.S., McGeoch, M.A., Obura, D., Onoda, Y., Pettorelli, N., Reyers, B., Sayre, R., Scharlemann, J.P.W., Stuart, S.N., Turak, E., Walpole, M. and Wegmann, M., 2013: Essential Biodiversity Variables. *Science*, **339**(6117): 277-278.
- Pert, P.L., Ens, E.J., Locke, J., Clarke, P.A., Packer, J.M. and Turpin, G., 2015: An online spatial database of Australian Indigenous Biocultural Knowledge for contemporary natural and cultural resource management. *Science of The Total Environment*, **534**: 110-121.
- Pidgeon, N. and Fischhoff, B., 2011: The role of social and decision sciences in communicating uncertain climate risks. *Nature Climate Change*, **1**(1): 35-41.
- Porter, J.H., Nagy, E., Kratz, T.K., Hanson, P., Collins, S.L. and Arzberger, P., 2009: New eyes on the world: advanced sensors for ecology. *Bioscience*, **59**(5): 385-397.
- Reichman, O.J., Jones, M.B. and Schildhauer, M.P., 2011: Challenges and Opportunities of Open Data in Ecology. *Science*, **331**(6018): 703-705.
- Rindfuss, R.R., Walsh, S.J., Turner, B.L., Fox, J. and Mishra, V., 2004: Developing a science of land change: challenges and methodological issues. *Proceedings of The National Academy of Sciences*, **101**(39): 13976-13981.
- Rüegg, J., Gries, C., Bond-Lamberty, B., Bowen, G.J., Felzer, B.S., McIntyre, N.E., Soranno, P.A., Vanderbilt, K.L. and Weathers, K.C., 2014: Completing the data life cycle: using information management in macrosystems ecology research. *Frontiers in Ecology and the Environment*, **12**(1): 24-30.
- Rundel, P.W., Graham, E.A., Allen, M.F., Fisher, J.C. and Harmon, T.C., 2009: Environmental sensor networks in ecological research. *New Phytologist*, **182**(3): 589-607.
- sCBD, 2010: Global biodiversity Outlook 3. Montreal.
- sCBD, 2014: Global Biodiversity Outlook 4. Secretariat of the Convention on Biological Diversity, Montreal.
- Scholes, R.J., Walters, M., Turak, E., Saarenmaa, H., Heip, C.H.R., Tuama, É.Ó., Faith, D.P., Mooney, H.A., Ferrier, S., Jongman, R.H.G., Harrison, I.J., Yahara, T., Pereira, H.M., Larigauderie, A. and Geller, G., 2012: Building a global observing system for biodiversity. *Current opinion in environmental sustainability*, **4**(1): 139-146.
- Shaw, A., Sheppard, S., Burch, S., Flanders, D., Wiek, A., Carmichael, J., Robinson, J. and Cohen, S., 2009: Making local futures tangible—synthesizing, downscaling, and visualizing climate change scenarios for participatory capacity building. *Global Environmental Change*, **19**(4): 447-463.
- Sheppard, S.R.J., 2005: Participatory decision support for sustainable forest management: a framework for planning with local communities at the landscape level in Canada. Sustainable forestry in the balance. *Journal of Forestry*, **4**: 187-195.
- Silvertown, J., 2009: A new dawn for citizen science. *Trends in Ecology & Evolution*, **24**(9): 467-471.
- Simoy, M.V., Fernández, G.J. and Canziani, G.A., 2013: An Individual-Based Model to Estimate the Daily Energetic Cost of Greater Rheas and Its Contribution on Population Recruitment. *Natural Resource Modeling*, **26**(3): 435-454.
- Sitch, S., Huntingford, C., Gedney, N., Levy, P.E., Lomas, M., Piao, S.L., Betts, R., Ciais, P., Cox, P., Friedlingstein, P., Jones, C.D., Prentice, I.C. and Woodward, F.I., 2008: Evaluation of the terrestrial carbon cycle, future plant geography and climate-carbon cycle feedbacks using five Dynamic Global Vegetation Models (DGVMs). *Global Change Biology*, **14**(9): 2015-2039.
- Skidmore, A.K., Pettorelli, N., Coops, N.C., Geller, G.N., Hansen, M., Lucas, R., Múcher, C.A., O'Connor, B., Paganini, M., Pereira, H.M., Schaepman, M.E., Turner, W., Wang, T. and Wegmann, M., 2015: Agree on biodiversity metrics to track from space. *Nature*, **523**(7561): 403-405.

- Sleeter, B.M., Sohl, T.L., Bouchard, M.A., Reker, R.R., Soulard, C.E., Acevedo, W., Griffith, G.E., Sleeter, R.R., Auch, R.F., Sayler, K.L., Prisley, S. and Zhu, Z., 2012: Scenarios of land use and land cover change in the conterminous United States: Utilizing the special report on emission scenarios at ecoregional scales. *Global Environmental Change*, **22**(4): 896-914.
- Smith, H.A. and Sharp, K., 2012: Indigenous climate knowledges. *Wiley Interdisciplinary Reviews: Climate Change*, **3**(5): 467-476.
- Smith, P., Haberl, H., Popp, A., Erb, K.-h., Lauk, C., Harper, R., Tubiello, F.N., Siqueira Pinto, A., Jafari, M., Sohi, S. and others, 2013: How much land-based greenhouse gas mitigation can be achieved without compromising food security and environmental goals? *Global Change Biology*, **19**(8): 2285-2302.
- Sparks, T.H., Butchart, S.H.M., Balmford, A., Bennun, L., Stanwell-Smith, D., Walpole, M., Bates, N.R., Bomhard, B., Buchanan, G.M., Chenery, A.M., Collen, B., Csirke, J., Diaz, R.J., Dulvy, N.K., Fitzgerald, C., Kapos, V., Mayaux, P., Tierney, M., Waycott, M., Wood, L. and Green, R.E., 2011: Linked indicator sets for addressing biodiversity loss. *Oryx*, **45**(03): 411-419.
- Stanton, J.C., Shoemaker, K.T., Pearson, R.G. and Akçakaya, H.R., 2015: Warning times for species extinctions due to climate change. *Global Change Biology*, **21**(3): 1066-1077.
- Tallis, H., Mooney, H., Andelman, S., Balvanera, P., Cramer, W., Karp, D., Polasky, S., Reyers, B., Ricketts, T., Running, S., Thonicke, K., Tietjen, B. and Walz, A., 2012: A Global System for Monitoring Ecosystem Service Change. *Bioscience*, **62**(11): 977-986.
- Ten Brink, B., Van der Esch, S., Kram, T., Van Oorschot, M., Alkemade, J.R.M., Ahrens, R., Bakkenes, M., Bakkes, J., Van den Berg, M., Christensen, V., Janse, J., Jeuken, M., Lucas, P., Manders, T., Van Meijl, H., Stehfest, E., Tabeau, A., Van Vuuren, D. and Wilting, H., 2010: Rethinking global biodiversity strategies: exploring structural changes in production and consumption to reduce biodiversity loss. Netherlands Environmental Assessment Agency (PBL), The Hague, the Netherlands.
- Tittensor, D.P., Walpole, M., Hill, S.L.L., Boyce, D.G., Britten, G.L., Burgess, N.D., Butchart, S.H.M., Leadley, P.W., Regan, E.C., Alkemade, R., Baumung, R., Bellard, C., Bouwman, L., Bowles-Newark, N.J., Chenery, A.M., Cheung, W.W.L., Christensen, V., Cooper, H.D., Crowther, A.R., Dixon, M.J.R., Galli, A., Gaveau, V., Gregory, R.D., Gutierrez, N.L., Hirsch, T.L., Höft, R., Januchowski-Hartley, S.R., Karmann, M., Krug, C.B., Leverington, F.J., Loh, J., Lojenga, R.K., Malsch, K., Marques, A., Morgan, D.H.W., Mumby, P.J., Newbold, T., Noonan-Mooney, K., Pagad, S.N., Parks, B.C., Pereira, H.M., Robertson, T., Rondinini, C., Santini, L., Scharlemann, J.P.W., Schindler, S., Sumaila, U.R., Teh, L.S.L., van Kolck, J., Visconti, P. and Ye, Y., 2014: A mid-term analysis of progress toward international biodiversity targets. *Science*, **346**(6206): 241-244.
- Turner, W., Rondinini, C., Pettorelli, N., Mora, B., Leidner, A.K., Szantoi, Z., Buchanan, G., Dech, S., Dwyer, J., Herold, M. and others, 2015: Free and open-access satellite data are key to biodiversity conservation. *Biological Conservation*, **182**: 173-176.
- UN, EU, FAO, OECD and WBG, 2014: System of Environmental-Economic Accounting 2012—Experimental Ecosystem Accounting. United Nations, European Union, Food and Agriculture Organization of the United Nations, Organisation for Economic Co-operation and Development, World Bank Group, ST/ESA/STAT/Ser.F/112, New York.
- Van Berkel, D.B., Carvalho-Ribeiro, S., Verburg, P.H. and Lovett, A., 2011: Identifying assets and constraints for rural development with qualitative scenarios: A case study of Castro Laboreiro, Portugal. *Landscape and Urban Planning*, **102**: 127-141.
- van Strien, A.J., Soldaat, L.L. and Gregory, R.D., 2012: Desirable mathematical properties of indicators for biodiversity change. *Ecological Indicators*, **14**(1): 202-208.
- Van Vuuren, D.P. and Carter, T.R., 2014: Climate and socio-economic scenarios for climate change research and assessment: reconciling the new with the old. *Climatic Change*, **122**(3): 415-429.
- Van Vuuren, D.P., Kok, M.T.J., Girod, B., Lucas, P.L. and de Vries, B., 2012a: Scenarios in Global Environmental Assessments: Key characteristics and lessons for future use. *Global Environmental Change*, **22**(4): 884-895.
- Van Vuuren, D.P., Bayer, L.B., Chuwah, C., Ganzeveld, L., Hazeleger, W., van den Hurk, B., Van Noije, T., O'Neill, B. and Strengers, B.J., 2012b: A comprehensive view on climate change: coupling of earth system and integrated assessment models. *Environmental Research Letters*, **7**(2): 024012.
- Vervoort, J.M., Kok, K., van Lammeren, R. and Veldkamp, T., 2010: Stepping into futures: Exploring the potential of interactive media for participatory scenarios on social-ecological systems. *Futures*, **42**(6): 604-616.

-
- Visconti, P., Bakkenes, M., Baisero, D., Brooks, T., Butchart, S.H.M., Joppa, L., Alkemade, R., Di Marco, M., Santini, L., Hoffmann, M., Maiorano, L., Pressey, R.L., Arponen, A., Boitani, L., Reside, A.E., van Vuuren, D.P. and Rondinini, C., 2015: Projecting Global Biodiversity Indicators under Future Development Scenarios. *Conservation Letters*, **Early View**.
- Waage, S. and Kester, C., 2014: Global Public Sector Trends in Ecosystem Services: 2009–2013. Business for Social Responsibility, San Francisco, CA, USA.
- Walz, A., Braendle, J.M., Lang, D.J., Brand, F., Briner, S., Elkin, C., Hirschi, C., Huber, R., Lischke, H. and Schmatz, D.R., 2014: Experience from downscaling IPCC-SRES scenarios to specific national-level focus scenarios for ecosystem service management. *Technological Forecasting and Social Change*, **86**: 21-32.
- Wiggins, A. and Crowston, K., 2011: From Conservation to Crowdsourcing: A Typology of Citizen Science. *2011 44th Hawaii International Conference on System Sciences (HICSS)*, 1-10.
-